

# ***INVERTER***

*VFD-200G Series*

*Frequency converter*

*Operation Manual*

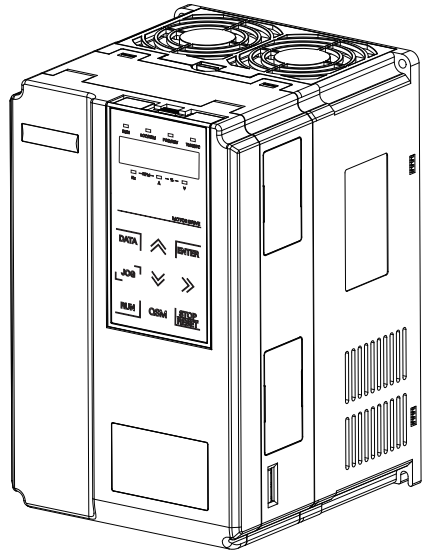

*Control and protect your motor*

# Preface

- Thanks for purchasing VFD-200G series frequency convertor!
- Please read the operation manual carefully to give full play to functions of frequency convertor, and ensure safety of users. Please hand the specification to final users for proper conservation.
- The figures in the specification are simply for explanations and they may be different from your ordered products.
- To upgrade product or change specifications, to promote convenience and accuracy of the specification, the contents of specification may be changed timely.
- If any questions about using, please contact with customer service center.
- If need to order the specification due to damage or loss, please contact with regional agents or customer service center directly.

## Introduction

General functions and descriptions of VFD-200G series frequency convertor:

- 1) Abundant voltage classes: support three voltage classes, namely single-phase 220V, three-phase 220V and three-phase 380V.
- 2) Abundant control mode: apart from vector control of velocity sensor, sensorless vector control and V/F control, support V/F separation control.
- 3) Abundant field bus: support Modbus-RTU and CANlink field bus.
- 4) Abundant encoder types: support difference encoder, open collector encoder and rotary transformer, etc.
- 5) Brand-new sensorless vector control algorithm  
Brand-new SVC creates better low-velocity stability, stronger low-frequency load capacity, and supports torque control of SVC.
- 6) Powerful background software: uploading, downloading parameters, real-time oscilloscope can be realized on background software.

Functions	Descriptions
Overheat protection of motor	After choosing VFD-200GPC1 expansion card, AI3 can receive temperature sensor input of motor (PT100, PT1000) to realize overheat protection
Fast current limiting	Avoid over-current fault of frequency convertor
Dual motor switch	Two sets of motor parameters can realize dual motor switch
Restore user parameters	Users can save or restore own parameter settings
Accurate AIAO	After factory calibration (or spot calibration), AIAO accuracy can be <20mv
Show customized parameters	Users can customize function parameters to be displayed
Show altered parameters	User can view function parameters after modification
Optional fault handing ways	Users can select action modes of convertor after confirming certain faults: free halting, deceleration halting, continual operation. The users can also select frequency for continual operation.
PID parameter switch	Two sets of PID parameters can switch by terminal or based on deviation
PID feedback loss detection	PID feedback loss detection value realizes protection during PID operation
DIDO positive/negative logic	Users can set positive/negative logic of DIDO
DIDO response delay	Users can set response delay time of DIDO
Run under instantaneous stop	Frequency convertor continues running within short time if instantaneous power <u>outage or voltage decrease</u>
Timing operation	Support timing operation for 6,500 minutes at most

Opening for inspection:

When opening the box, please carefully confirm if the nameplate model and rated value of frequency convertor are consistent with order. The package contains ordered machine, qualification certificate, operation manual and warranty bill.

If any damage during transportation or certain omission, please contact with our company or supplier.

# Contents

Preface.....	1
brief introduction.....	2
Chapter 1 chapter Safety information and precautions.....	5
1.1 Safety issues.....	5
1.2 Precautions.....	7
Chapter 2Product information.....	9
2.1 Naming rules.....	9
2.2 Nameplate.....	9
2.3 VFD-200G series frequency converter.....	9
2.4 Technical specifications.....	11
2.5 Outside drawing mounting hole dimension.....	13
2.6 Optional accessories.....	20
2.7 Routine maintenance of frequency converter.....	20
2.8 Warranty.....	21
2.9 Model selection guidance of braking parts.....	21
Chapter 3Mechanical and electrical installation.....	23
3.1 Mechanical installation.....	23
3.2 Electrical installation.....	25
Chapter4 Operation and display.....	34
4.1 Interface introductions of operation and display.....	34
4.2 Viewing and modifying methods of function code.....	35
4.3 Parameter display mode.....	36
4.4 User customization parameters.....	37
4.5 Method for viewing state parameter.....	37
4.6 Password settings.....	38
4.7 Automatic tuning of motor parameters.....	38
Chapter5Functional parameter table.....	39
Chapter6 Parameter description .....	68
Group P0 Basic function group.....	68
Group P1 Parameters of 1 <sup>st</sup> motor .....	77
Group P2 Vector control parameters .....	79
Group P3 V/F control parameters .....	81
Group P4 Input terminal .....	85
Group P5 Output terminal.....	94

Group P6 Start stop control.....	99
Group P7 Keyboard and display.....	103
Group P8 Auxiliary function .....	106
Group P9 Fault and protection.....	118
Group PA Process control PID function.....	123
Group PB Swing Frequency, Fixed Length and Counting.....	128
Group PC Multi-section instructions and simple PLC function.....	131
Group PD Communication parameters.....	135
Group PE Custom function code .....	135
Group PP User password.....	137
Group A0 Torque control and limit parameters.....	139
Group A2 2nd motor.....	140
Group A5 Control optimization parameters.....	143
Group A6 AI curve setting .....	145
Group A7 User programmable function .....	147
Group ACAIAO correction.....	147
Group U0Monitor.....	149
Chapter7 EMC ( electromagnetic compatibility ) .....	151
7.1 Definition.....	151
7.2 Introduction of EMC standard.....	151
7.3 EMC guidance.....	151
Chapter8 Fault diagnosis and Countermeasures.....	153
8.1 Failure alarm and Countermeasures.....	153
8.2 Common faults and handling methods.....	160
Appendix A: Multi-function card VFD-200GPC1 .....	162
Appendix B: Instructions of IO expansion card (VFD-200GIO1).....	164
Appendix C: Instructions of expansion card for common encoder.....	165
Appendix D: Instructions of CANlink communication expansion card(VFD-200GCAN1).....	167
Appendix E: Instructions of RS-485 communication expansion card(VFD-200GTX1).....	168
Appendix F: VFD-200G Modbus communication protocol.....	169

## Chapter 1 Safety information and precautions

Safety definition: safety precautions are divided into two categories in the manual:

 **Danger:** serious injury and death may occur due to operation against requirements;

 **Caution:** moderate or minor injury, equipment damage may occur due to operation against requirements;

Please read this chapter carefully when installing, debugging and maintaining the system, and operate as per safety precautions. The company will not be liable for any injury and loss caused by operation against requirements.

### 1.1 Safety issues

#### 1.1.1 Before installation:

 <b>Danger</b>
<ul style="list-style-type: none"><li>● If any water in system, lack or damage of component when opening box, please do not install!</li><li>● If any unconformity between packing list and actual object, please do not install!</li></ul>

 <b>Danger</b>
<ul style="list-style-type: none"><li>● Please move the equipment gently, otherwise it may be damaged!</li><li>● If any damaged driver or frequency convertor missing parts, please do not use! There's risk of injury!</li><li>● Do not touch components of control system with hands, otherwise there's danger of static electricity!</li></ul>

#### 1.1.2 During installation:

 <b>Danger</b>
<ul style="list-style-type: none"><li>● Install on flame retardant objects like metal and keep away from combustible, otherwise fire may occur!</li><li>● Do not screw fixed bolts of components at random especially those with red marking!</li></ul>

 <b>Caution</b>
<ul style="list-style-type: none"><li>● Do not put wire head or bolt in driver, otherwise the driver may be damaged!</li><li>● Please install the driver in place with little vibration and keep out of the sun.</li><li>● When above two frequency convertors are put in the same cabinet, please pay attention to installation position to ensure heat dissipation effect.</li></ul>

## 1.1.3 During wiring:

 Danger
<ul style="list-style-type: none"><li>● Please observe the manual guidance and construct by professional electric engineering staff, otherwise danger may occur!</li><li>● Breaker should separate frequency convertor and power, otherwise fire may occur!</li><li>● Please ensure that power is at zero-energy state before wiring, otherwise electric shock may occur!</li><li>● Please keep correct earthing of convertor as per standards, otherwise electric shock may occur!</li></ul>

 Danger
<ul style="list-style-type: none"><li>● Do not connect input power to output terminal (U, V, W) on frequency convertor. Pay attention to marking on wiring terminal and do not wire wrongly, otherwise driver may be damaged!</li><li>● Ensure that all wirings conform to EMC requirements and regional safety standard. All wire diameters refer to suggestions in manual, otherwise accident may occur!</li><li>● Do not connect brake resistor directly between DC bus (+) (-) terminals, otherwise fire may occur!</li><li>● Encoder shall use shielded wire single and ensure reliable earthing for terminal of shielding layer!</li></ul>

## 1.1.4 Before electrifying:

 Caution
<ul style="list-style-type: none"><li>● Please confirm the consistence between voltage class of input power and rated voltage class of frequency convertor; correctness of wiring positions of power input terminal (R, S, T) and output terminals (U, V, W). Check if any short circuit of peripheral circuit connecting to driver and if wiring circuit is tightened, otherwise driver may be damaged!</li><li>● Neither part of frequency convertor needs withstand voltage test as the product has been tested!</li></ul>

 Danger
<ul style="list-style-type: none"><li>● Electrify frequency convertor after covering cover plate, otherwise electric shock may occur!</li><li>● Wiring of all periphery accessories shall comply with manual guidance and keep correct wiring as per circuit connection method in manual, otherwise accident may occur!</li></ul>

## 1.1.5 After electrifying:

 Danger
<ul style="list-style-type: none"><li>● Do not open cover plate after electrifying, otherwise electric shock may occur!</li><li>● Do not touch driver or peripheral circuit with wet hands, otherwise electric shock may occur!</li><li>● Do not touch any input or output terminal of frequency convertor, otherwise electric shock may occur!</li><li>● When firstly electrifying, frequency convertor will conduct security detection of external strong-current loop, and do not touch U, V, W wiring terminal of driver or wiring terminal of motor, otherwise electric shock may occur!</li></ul>

### 1.1.6 During operation:

 Danger
<ul style="list-style-type: none"><li>● Do not touch cooling fan or discharge resistance to feel temperature, otherwise burn may occur!</li><li>● Non-professional artisan shall not detect signal, otherwise personal injury or device damage may occur!</li></ul>

 Caution
<ul style="list-style-type: none"><li>● Avoid things falling in device during operation of frequency converter, otherwise damage may occur!</li><li>● Do not control driver by turning on or off contactor, otherwise damage may occur!</li></ul>

### 1.1.7 During maintenance:

 Danger
<ul style="list-style-type: none"><li>● Do not repair or maintain device when electrifying, otherwise electric shock may occur!</li><li>● Only maintain and repair driver when voltage of frequency converter &lt; DC36V since 2 minutes after outage, otherwise residual electric charge on capacitance may cause personal injury!</li><li>● Those without professional training shall not repair or maintain frequency converter, otherwise personal injury or device damage may occur!</li><li>● Parameters shall be set after changing frequency converter, all pluggable plugins shall be inserted and plugged after outage!</li></ul>

## 1.2 Precautions

### 1.2.1 Insulation inspection of motor

When firstly using motor, using motor again after putting for a long time and regularly checking motor, insulation inspection of motor is essential to prevent damaging frequency converter due to invalid insulation of motor winding. During insulation inspection, separate motor wire from frequency converter. 500V voltage-type megger is suggested and ensure measured insulation resistance  $\geq 5M\Omega$ .

### 1.2.2 Thermal protection of motor

If selected motor does not match with rated capacity of frequency converter, especially if rated power is larger than that of frequency converter, please adjust related parameter values of motor protection or install thermal relay in front of motor for protection.

### 1.2.3 Operation above power frequency

The frequency converter offers output frequency at 0Hz ~ 3200Hz. If users need to operate at above 50Hz, please consider the tolerance of mechanical device.

### 1.2.4 Vibration of mechanical device

Mechanical resonance point of load device may exist at certain output frequency of frequency converter, and hopping frequency parameter can be set to avoid.

### 1.2.5 About heating and noise of motor

Output voltage of frequency converter is PWM wave containing certain harmonic, so temperature rise, noise and vibration of motor will slightly increase when comparing with power frequency operation.



#### 1.2.6 Voltage-sensitive parts or capacitance of improving power factor exist on output side

Output of frequency convertor is PMB wave. If capacitance of improving power factor or voltage dependent resistor for thunder prevention is installed on output side, instantaneous over current and even damage of frequency convertor can be caused easily. Please do not use.

#### 1.2.7 Switching devices such as contactor for input and output terminals of frequency convertor

If contactor is installed between power and input terminal of frequency convertor, this contactor is not allowed to control the start and stop of frequency convertor. If this contactor is required to control the start and stop of frequency convertor, the interval should be not less than one hour. Frequent charging and discharging will easily reduce the lifespan of capacitor within frequency convertor. If switching devices such as contactor are installed between output terminal and motor, ensure the operation of frequency convertor without output, otherwise module damage may occur easily.

#### 1.2.8 Use beyond rated voltage value

It's not suitable to use VFD-200G series frequency convertor beyond operating voltage range allowed by the manual, otherwise device damage may be caused. If necessary, please use corresponding voltage boosting or dropping equipment for voltage transformation.

#### 1.2.9 Three-phase input changes to be two-phase input

Do not change three-phase frequency convertor to be two-phase, otherwise fault or damage may occur.

#### 1.2.10 Lightening impulse protection

There's lightening stroke over-current protection device in frequency convertor, so it has certain self-protection ability for inductive thunder. If lightening stroke is frequent in the place of client, additional protection in front of frequency convertor is essential.

#### 1.2.11 Altitude and derating use

In the region with altitude exceeding 1,000m, the heat dissipation effect of frequency convertor weakens due to thin air, so it's necessary to derate for use. Please contact our company for consultation.

#### 1.2.12 About adaptive motor

- 1) Standard adaptive motor is four-pole squirrel-cage asynchronous induction motor. If it's not above motor, please select frequency convertor as per rated current of motor.
- 2) Cooling fan and rotor spindle of non-variable frequency motor is coaxial connection. If rotation speed reduces, cooling effect of fan will reduce, so the occasion of overheating motor should be installed with strong exhaust fan or changed to be variable frequency motor.
- 3) Standard parameters of adaptive motor have been built in frequency convertor. It's necessary to identify motor parameters or modify default value based on actual situation to conform to actual value as far as possible, otherwise operation effect and protection performance may be affected.
- 4) Short circuit of cable or within motor can lead to alarm and even explosion of frequency convertor. Please firstly conduct insulation short-circuit test for initially installed motor and cable, and it's also essential for daily maintenance. Please completely separate frequency convertor from tested part when conducting the test.

## Chapter 2 Product information

### 2.1 Naming rule

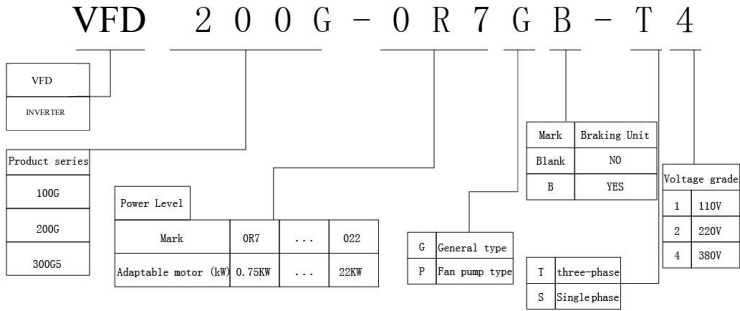

Figure 2-1 Naming specification

### 2.2 Nameplate

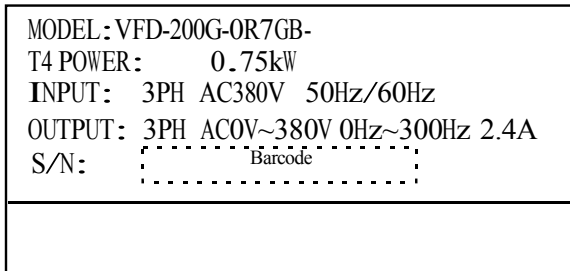

Figure 2-2 Nameplate

### 2.3 VFD-200G series frequency converter

Figure 2-1 Model and technical data of VFD-200G frequency converter

Model of frequency converter	Power capacity kVA	Input current A	Output current A	Adaptive motor kW      HP	
Single-phase power: 220V, 50/60Hz					
VFD-200G-0R4GB-S2	1.0	5.4	2.3	0.4	0.5
VFD-200G-0R7GB-S2	1.5	8.2	4.0	0.75	1
VFD-200G-1R5GB-S2	3.0	14.0	7.0	1.5	2
VFD-200G-2R2GB-S2	4.0	23.0	9.6	2.2	3
Three-phase power: 220V, 50/60Hz					
VFD-200G-0R4GB-T2	1.5	3.4	2.1	0.4	0.5

Model of frequency convertor	Power capacity	Input current	Output current	Adaptive motor	
VFD-200G-0R7GB-T2	3.0	5.0	3.8	0.75	1
VFD-200G-1R5GB-T2	4.0	5.8	5.1	1.1	1.5
VFD-200G-2R2GB-T2	5.9	10.5	9.0	2.2	3
VFD-200G-3R7GB-T2	8.9	14.6	13.0	3.7	5
VFD-200G-5R5GB-T2	17.0	26.0	25.0	5.5	7.5
VFD-200G-7R5GB-T2	21.0	35.0	32.0	7.5	10
VFD-200G-11G-T2	30.0	46.5	45.0	11	15
VFD-200G-15G-T2	40.0	62.0	60.0	15	20
VFD-200G-18R5G-T2	57.0	76.0	75.0	18.5	25
VFD-200G-22G-T2	69.0	92.0	91.0	22	30
VFD-200G-30G-T2	85.0	113.0	112.0	30	40
VFD-200G-37G-T2	114.0	157.0	150.0	37	50
VFD-200G-45G-T2	134.0	180.0	176.0	45	60
VFD-200G-55G-T2	160.0	214.0	210.0	55	70
VFD-200G-75G-T2	231.0	307.0	304.0	75	100
Three-phase power: 380V, 50/60Hz					
VFD-200G-0R7GB-T4	1.5	3.4	2.1	0.75	1
VFD-200G-1R5GB-T4	3.0	5.0	3.8	1.5	2
VFD-200G-2R2GB-T4	4.0	5.8	5.1	2.2	3
VFD-200G-3R7GB-T4	5.9	10.5	9.0	3.7	5
VFD-200G-5R5GB-T4 VFD-200G-7R5PB-T4	8.9	14.6	13.0	5.5	7.5
VFD-200G-7R5GB-T4 VFD-200G-11PB-T4	11.0	20.5	17.0	7.5	10
VFD-200G-11GB-T4 VFD-200G-15PB-T4	17.0	26.0	25.0	11.0	15
VFD-200G-15GB-T4 VFD-200G-18R5PB-T4	21.0	35.0	32.0	15.0	20
VFD-200G-18R5G-T4 VFD-200G-22P-T4	24.0	38.5	37.0	18.5	25
VFD-200G-22G-T4 VFD-200G-30P-T4	30.0	46.5	45.0	22	30
VFD-200G-30G-T4 VFD-200G-37P-T4	40.0	62.0	60.0	30	40
VFD-200G-37G-T4 VFD-200G-45P-T4	57.0	76.0	75.0	37	50
VFD-200G-45G-T4 VFD-200G-55P-T4	69.0	92.0	91.0	45	60
VFD-200G-55G-T4 VFD-200G-75P-T4	85.0	113.0	112.0	55	70
VFD-200G-75G-T4 VFD-200G-90P-T4	114.0	157.0	150.0	75	100
VFD-200G-90G-T4 VFD-200G-110P-T4	134.0	180.0	176.0	90	125
VFD-200G-110G-T4 VFD-200G-132P-T4	160.0	214.0	210.0	110	150
VFD-200G-132G-T4 VFD-200G-160P-T4	192.0	256.0	253.0	132	175
VFD-200G-160G-T4 VFD-200G-200P-T4	231.0	307.0	304.0	160	210
VFD-200G-200G-T4 VFD-200G-220P-T4	250.0	385.0	377.0	200	260
VFD-200G-220G-T4 VFD-200G-250P-T4	280.0	430.0	426.0	220	300
VFD-200G-250G-T4 VFD-200G-280P-T4	355.0	468.0	465.0	250	350
VFD-200G-280G-T4 VFD-200G-315P-T4	396.0	525.0	520.0	280	370
VFD-200G-315G-T4 VFD-200G-355P-T4	445.0	590.0	585.0	315	500
VFD-200G-355G-T4 VFD-200G-400P-T4	500.0	665.0	650.0	355	420
VFD-200G-400G-T4 VFD-200G-450P-T4	565.0	785.0	725.0	400	530

## 2.4 Technical specifications

Figure 2-2 Technical specifications of frequency converter

Items		Specifications		
Basic functions	Highest frequency	Vector control: 0~300Hz V/F control: 0~3200Hz		
	Carrier frequency	0.5kHz~16kHz Adjust carrier frequency automatically based on load characteristic		
	Input frequency resolution	Number setting: 0.01Hz Simulation setting: highest frequency $\times 0.025\%$		
	Control mode	SVC FVC V/F control		
	Starting torque	G-style machine: 0.5Hz/150% (SVC); 0Hz/180% (FVC) P-style machine: 0.5Hz/100%		
	Speed regulation range	1: 100 (SVC)	1: 1000 (FVC)	
	Speed stabilizing precision	$\pm 0.5\%$ (SVC)	$\pm 0.02\%$ (FVC)	
	Torque control precision	$\pm 5\%$ (FVC)		
	Overload capacity	G-style machine: 150% rated current at 60s; 180% rated current at 3s P-style machine: 120% rated current at 60s; 150% rated current at 3s		
	Torque promotion	Automatic torque promotion; manual torque promotes by 0.1%~30.0%		
	V/F curve	Three ways: linear type; multipoint type; N <sup>th</sup> power type V/F curve (1.2 power, 1.4 power, 1.6 power, 1.8 power, 2 power)		
	V/F separation	2 ways: full separation, semi-separation		
	Acceleration/deceleration curves	Linear or S-curve acceleration/deceleration way. Four kinds of acceleration/deceleration time Acceleration/deceleration time range: 0.0~6500.0s		
	DC braking	DC braking frequency: 0.00Hz~maximum frequency; Braking time: 0.0s~36.0s braking action; Current value: 0.0%~100.0%		
	Inching control	Inching frequency range: 0.00Hz~50.00Hz; Inching acceleration/deceleration time 0.0s~6500.0s		
	Simple PLC, multi-stage velocity operation	Realize 16-stage velocity operation at most through built-in PLC or control terminal		
	Built-in PID	Easy to realize process control, closed-loop control system		
	Automatic voltage regulation	Keep constant output voltage automatically if any change of network voltage		
	Overvoltage, overcurrent, stalling control	Limit current/voltage automatically during operation, prevent frequent tripping caused by over-current and over-voltage		
	Fast current-limiting function	Reduce over-current fault, protect normal operation of converter		
Torque limit and control	"Nawy" character limit torque during operation, prevent frequent overcurrent tripping, closed-loop vector mode can realize torque control			

Items		Specifications
Individualized functions	Excellent performance	Realize motor control with high-performance current vector control
	Operate under instantaneous stop	Offset reduced voltage through load feedback energy if instantaneous outage, keep continual operation of frequency converter within short time
	Fast current limiting	Avoid frequent over-current fault of frequency converter
	Timing control	Timing control function: set time range 0.0Min~6500.0Min
	Multi-motor switch	2 sets of motor parameters realize switch control of 2 motors
	Multi-threading bus	Support two kinds of spot field bus: RS-485, CANlink
	Overheating protection	Optional multi-function card, analog input A13 can receive motor temperature sensor input (PT100, PT1000)
	Multi encoder	Support various encoders such as differentiation, open collector and rotary transformer
	Programmable by users	Optional user programmable card realizes secondary development
	Powerful background software	Support parameter operation and virtual oscilloscope function. Realize graphic monitoring of internal status of frequency converter through virtual oscilloscope
Operation	Command source	Given operation panel, given control terminal, given serial communication port. Switch through multiple ways
	Frequency source	10 frequency sources: given digit, given analog voltage, given analog current, given pulse, given serial port. Switch through multiple ways
	Auxiliary frequency source	10 auxiliary frequency sources. Realize auxiliary frequency trimming and frequency synthesis flexibly
	Input terminals	Standard: 5 digital input terminals, in which 1 terminal supports high-speed impulse input at 100Hz 2 analog input terminals, in which 1 supports voltage input at 0~10V, 1 supports voltage support at 0~10V or current input at 4~20mA Expansion capability: 5 digital input terminals 1 analog input terminal supports voltage support at 0~10V
	Output terminals	Standard: 1 high-speed pulse output terminal (open collector is optional), support square signal output at 0~100kHz 1 digital output terminal 1 relay output terminal 1 analog output terminal supports current input at 0~20mA or voltage support at 0~10V Expansion capability: 1 digital output terminal 1 relay output terminal 1 analog output terminal supports current input at 0~20mA or voltage support at 0~10V

Items		Specifications
Display and keyboard operation	LED display	Display parameters
	Key locking and function selection	Partial or all locking of keys, define function range of some keys to prevent misoperation
	Protection function	Short-circuit detection of motor when electrifying, input/output default phase protection, over-current protection, overvoltage protection, undervoltage protection, overheating protection, overload protection
	Optional accessories	LCD operation panel, braking unit, multi-function expansion card, IO expansion card, RS485 communication card, CANlink communication card, differential input PG card, rotary transformer PG card, OC input PG card
Operating environment	Using place	Indoor without direct sunlight, dust, corrosive gas, combustible gas, oil mist, water vapor, dropping water or salinity
	Altitude	< 1,000m
	Environment temperature	-10℃~+40℃ (environment temperature at 40℃~50℃, please derate to use)
	Humidity	< 95%RH, no condensing drops
	Virbration	< 5.9m/s <sup>2</sup> (0.6g)
	Storage temperature	-20℃~+60℃

## 2.5 Outside drawing mounting hole dimension

### 2.5.1 Outside drawing

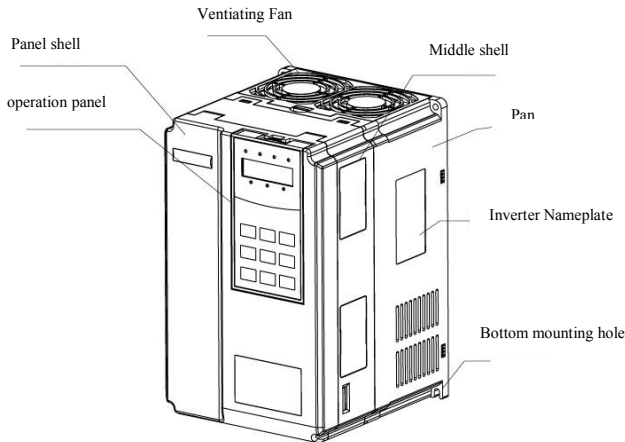

Figure 2-3 Outside drawing of VFD-200G

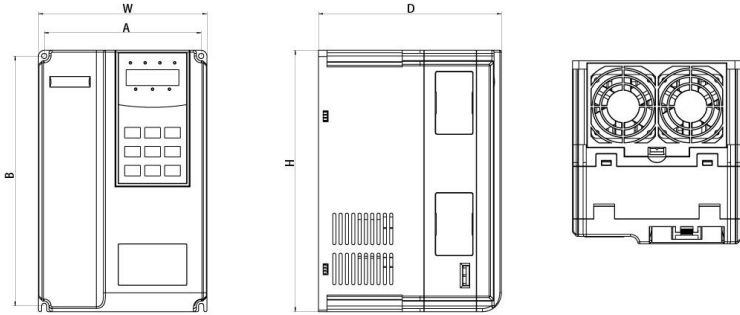

Figure 2-4 Schematic diagram of external dimension and mounting dimension of VFD-200G plastic structure

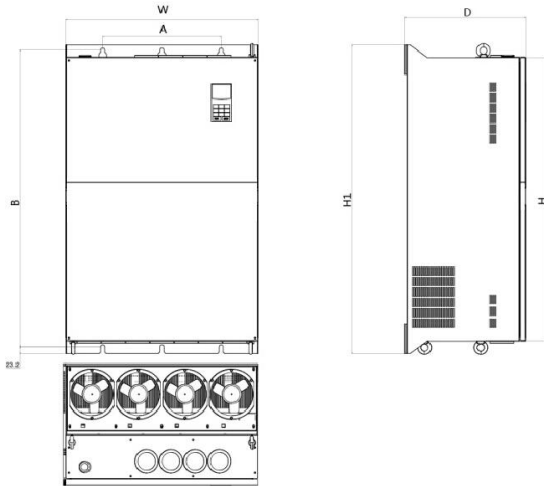

Figure 2-5 Schematic diagram of external dimension and mounting dimension of VFD-200G metal plate structure

Shell structures of VFD-200G series models are as follow:

Model	Shell type
Single-phase 220V	
0.4kW~2.2kW	Plastic structure
Three-phase 220V	
0.4kW~7.5kW	Plastic structure
11kW~75kW	Metal plate structure
Three-phase 380V	
0.75kW~15kW	Plastic structure
18.5kW~400kW	Metal plate structure

5.5.2 Outside drawing and mounting hole dimension (mm) of VFD-200G frequency converter

Figure 2-3 Outside drawing and mounting hole dimension of VFD-200G

Model of frequency converter	Mounting hole (mm)		External dimension (mm)				Hole diameter	Weight (kg)
	A	B	H	H1	W	D		
<b>Single-phase 220V</b>								
VFD-200G-0R4GB-S2	114	172	186	/	125	159	Ø5.0	1.7
VFD-200G-0R7GB-S2								
VFD-200G-1R5GB-S2								
VFD-200G-2R2GB-S2								
<b>Three-phase 220V</b>								
VFD-200G-0R4GB-T2	114	172	186	/	125	159	Ø5.0	1.7
VFD-200G-0R7GB-T2								
VFD-200G-1R5GB-T2								
VFD-200G-2R2GB-T2								
VFD-200G-3R7GB-T2	149	237	248	/	160	174	Ø5.0	3.2
VFD-200G-5R5GB-T2								
VFD-200G-7R5GB-T2								
VFD-200G-11G-T2	190	304	322	/	208	190	Ø6.0	6.4
VFD-200G-15G-T2								



Model of frequency convertor	Mounting hole (mm)		External dimension (mm)				Hole diameter	Weight (kg)
	A	B	H	H1	W	D		
VFD-200G-18R5-T2	190	304	322	/	208	190	Ø6.0	6.4
VFD-200G-22G-T2	220	453	435	475	270	222	Ø9.0	17.4
VFD-200G-30G-T2								
VFD-200G-37G-T2								
VFD-200G-45G-T2	250	576	550	600	355	290	Ø9.0	24.4
VFD-200G-55G-T2								
VFD-200G-75G-T2								
<b>Three-phase 380V</b>								
VFD-200G-0R7GB-T4	114	172	186	/	125	159	Ø5.0	1.7
VFD-200G-1R5GB-T4								
VFD-200G-2R2GB-T4								
VFD-200G-3R7GB-T4 VFD-200G-5R5PB-T4	149	237	248	/	160	174	Ø5.0	3.2
VFD-200G-5R5GB-T4 VFD-200G-7R5PB-T4								
VFD-200G-7R5GB-T4 VFD-200G-11PB-T4								
VFD-200G-11GB-T4 VFD-200G-15PB-T4								
VFD-200G-15GB-T4 VFD-200G-18R5PB-T4	190	305	322	/	208	192	Ø6.0	6.5
VFD-200G-18R5G-T4 VFD-200G-22P-T4								
VFD-200G-22G-T4 VFD-200G-30P-T4								
VFD-200G-30G-T4 VFD-200G-37P-T4	220	453	435	475	270	222	Ø9.0	17.4
VFD-200G-37G-T4 VFD-200G-45P-T4								
VFD-200G-45G-T4 VFD-200G-55P-T4								
VFD-200G-55G-T4 VFD-200G-75P-T4								
VFD-200G-75G-T4 VFD-200G-90P-T4	250	576	550	600	355	290	Ø9.0	24.4
VFD-200G-90G-T4 VFD-200G-110P-T4								
VFD-200G-110G-T4 VFD-200G-132P-T4								
VFD-200G-132P-T4								
VFD-200G-90G-T4 VFD-200G-110P-T4 VFD-200G-110G-T4 VFD-200G-132P-T4	260	745	700	784	385	323	Ø11.5	60.2

Model of frequency converter	Mounting hole (mm)		External dimension (mm)				Hole diameter	Weight (kg)
	A	B	H	H1	W	D		
VFD-200G-132G-T4 VFD-200G-160P-T4	300	865	820	904	440	353	Ø13	87.6
VFD-200G-160G-T4 VFD-200G-200P-T4								
VFD-200G-200G-T4 VFD-200G-220P-T4								
VFD-200G-220G-T4 VFD-200G-250P-T4	400	1000	957	1040	650	406	Ø13	192.4
VFD-200G-250G-T4 VFD-200G-280P-T4								
VFD-200G-280G-T4 VFD-200G-315P-T4								
VFD-200G-315G-T4 VFD-200G-355P-T4	600	1260	1153	1300	815	424	Ø13	316.4
VFD-200G-355G-T4 VFD-200G-400P-T4								
VFD-200G-400G-T4 VFD-200G-450P-T4								

2.5.3 External dimension of display panel

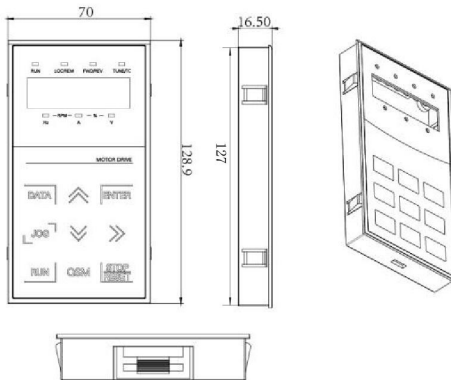

Figure 2-6 External dimension of display panel

Hole size of display panel:

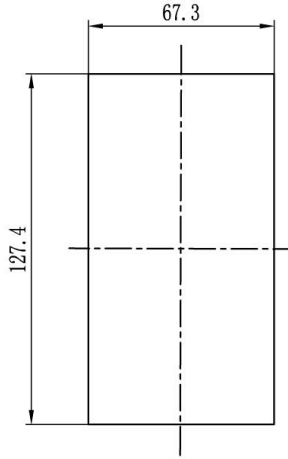

Figure 2-7 Hole size of display panel

### 2.5.4 Dimensional drawing of external DC reactor

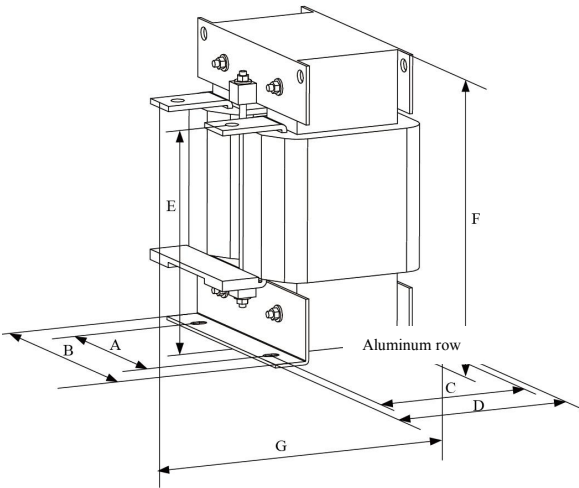

Figure 2-8 Dimensional drawing of external DC reactor

## Model of adaptive frequency convertor

Model of adaptive frequency convertor	A	B	C	D	E	F	G	Fixed hole	Hole diameter	Electric reactor model
VFD-200G-37G/45G-T2	160	190	125	161	192	255	195	10*15	Ø12	DCL-0200
VFD-200G-75G/90P/90G-T4										
VFD-200G-55G-T2										
VFD-200G-110P/110G/132P-T4	160	190	125	161	192	255	195	10*15	Ø12	DCL-0250
VFD-200G-75G-T2										
VFD-200G-132G/160P/160G-T4										
VFD-200G-200P/200G-/220P/220G/250P-T4	190	230	93	128	250	325	200	13*18	Ø15	DCL-0600
VFD-200G-250G/280P/280G/315P-T4										
VFD-200G-315G/355P/355G/400P/400G/450P-T4										
	224	250	135	165	260	330	235	12*20	Ø14	DCL-1000

Note: non-standard ones can be customized if any special requirements

Installation way of external DC reactor: when installing VFD-200G series frequency convertor, users need to remove the short-circuit copper bar between wiring terminal P1 and (+) of major loop, connect DC reactor between P1 and (+), keep no polarity of wiring between reactor terminal and convertor terminal P1, (+). After installing DC reactor, short-circuit copper bar between P1 and (+) is not necessary.

## 2.6 Optional accessories

Table 2-6 Accessories of VFD-200G frequency convertor

Name	Model	Function	Remark
External brake unit	SNBU	18.5kW and above external brake unit	75kW and above adopts multi-parallel connection
Multifunction expansion card	IO-MINI-V03	It can add five figures input and one analog voltage input. AI3 is isolate analog quantity that can connects with PT100 and PT1000; one relay output, one figure output and one analog voltage output with RS485 / CAN	Suitable for models of 3.7KW and above
I/O expansion card	VFD-200GIO1	It can add three figures input	Suitable for whole series
MODBUS communication card	RS485	With isolating RS-485 communication card	Suitable for whole series
CANlink communication expansion card	CANLINK-V03	CANlink communication adapter card	Suitable for whole series
Interface card of differential encoder	VFD-200GPG1	Interface card of differential rotary encoder, adaptive for 5V power source	Suitable for whole series
Interface card of rotary transformer	VFD-200GPG2	Suitable for rotating encoder, driving frequency 10kHz, DB9 interface	Suitable for whole series
Interface card of open collector encoder	VFD-200GPG3	Interface card of open collector encoder, with 1: 1 frequency dividing output, adaptive for 15V power source	Suitable for whole series
Introduced LED operating panel	SNKE	Introduced LED display and operating keyboard	Suitable for SN series
Extension cable	SNCAB	Introduced extension cable	Standard configuration 3 meter

## 2.7 Routine maintenance of frequency convertor

## 2.7.1 Routine maintenance

The influence of environment temperature, humidity, dust and vibration will lead to aging of internal components and potential fault, or reduce lifespan of frequency convertor, so it's necessary to conduct routine and regular maintenance.

Routine inspection items:

- 1) If any abnormal change of sound during motor operation
- 2) If any vibration during motor operation
- 3) If any change of installing environment for frequency convertor
- 4) If normal work of cooling fan for frequency convertor
- 5) If overheating of frequency convertor

## 2.7.2 Regular inspection

Regular inspection items:

- 1) Inspect air channel and clean regularly
- 2) Inspect if any loosening of screw
- 3) Inspect if any arc trace of wiring terminal

### 2.7.3 Storage of frequency converter

After purchasing frequency converter, users should pay attention to temporary and long-term storage:

1. Put in packaging box of our company as per original package for storage.

2. Long-term storage will lead to deterioration of electrolytic capacitor. Ensure electrifying once for at least 5 hours within 2 years, and voltage regulator should be used to gradually increase input voltage to rated value.

### 2.8 Warranty

Free maintenance only suit to frequency converter. If any fault or damage under normal use, our company is liable for maintenance for 18 months (since the date of leaving factory and barcode on machine prevails). If beyond 18 months, rational maintenance fee will be charged. Under below conditions, certain maintenance fee will be charged within 18 months: device damage caused by violating stipulations in manual; damage caused by fire, flood and abnormal voltage, etc; damage caused by using frequency converter for abnormal functions. Related service fee will be calculated as per unified standard of manufacturer. If any contract, the contract will prevail.

### 2.9 Model selection guidance of braking parts

Figure 2-7 is guidance data. Users can select different resistance value and power based on actual situation (but resistance value should not be lower than recommended value in figure, the power can be large). The selection of braking resistance depends on motor power in actual application system, and it's related to system inertia, deceleration time, potential energy load, so uses can select based on actual situation. The larger the system inertia, the shorter the deceleration time and the frequency the braking will be, so braking resistance should select large power and little resistance value.

#### 2.9.1 Selection of resistance value

During braking, regenerated energy of motor is almost fully consumed on braking resistance. Formula is below:  $U \cdot I / R = P_b$

U----braking voltage of stable braking (vary with different systems, generally 700V for 380VAC)

P<sub>b</sub>----braking power

#### 2.9.2 Power selection of braking resistance

In theory, power of braking resistance conforms with braking power.

Derating to 70% can be used.

Formula:  $0.7 \cdot P_r = P_b \cdot D$

P<sub>r</sub>----power of resistance; D----braking frequency (proportion in whole process during regeneration)

Elevator-----20% ~30%

Uncoil/Coil ----20 ~30%

Centrifuge-----50%~60%

Casual braking load----5%

10% in general

Figure 2-7 Model selection of braking parts of VFD-200G

Model of frequency converter	Recommended power	Recommended resistance value	Braking unit	Note
Single-phase 220V				
VFD-200G-0R4GB-S2	80W	≥200Ω	Standard built-in	No special instructions
VFD-200G-0R7GB-S2	80W	≥150Ω		
VFD-200G-1R5GB-S2	100W	≥100Ω		
VFD-200G-2R2GB-S2	100W	≥70Ω		

Three-phase 220V				
VFD-200G-0R4GB-T2	150W	$\geq 150\Omega$	Standard built-in	No special instructions
VFD-200G-0R7GB-T2	150W	$\geq 110\Omega$		
VFD-200G-1R1GB-T2	250W	$\geq 100\Omega$		
VFD-200G-2R2GB-T2	300W	$\geq 65\Omega$		
VFD-200G-3R7GB-T2	400W	$\geq 45\Omega$		
VFD-200G-5R5GB-T2	800W	$\geq 22\Omega$		
VFD-200G-7R5GB-T2	1000W	$\geq 16\Omega$		
VFD-200G-11G-T2	1500W	$\geq 11\Omega$	External	No special instructions
VFD-200G-15G-T2	2500W	$\geq 8\Omega$		
VFD-200G-18R5G-T2	3.7 kW	$\geq 8.0\Omega$	External	SNBU-35-A
VFD-200G-22G-T2	4.5 kW	$\geq 8\Omega$	External	SNBU-35-A
VFD-200G-30G-T2	5.5 kW	$\geq 4\Omega$	External	SNBU-70-A
VFD-200G-37G-T2	7.5 kW	$\geq 4\Omega$	External	SNBU-70-A
VFD-200G-45G-T2	4.5 kW $\times 2$	$\geq 4\Omega \times 2$	External	SNBU-70-A $\times 2$
VFD-200G-55G-T2	5.5 kW $\times 2$	$\geq 4\Omega \times 2$	External	SNBU-70-A $\times 2$
VFD-200G-75G-T2	16kW	$\geq 1.2\Omega$	External	SNBU-200-A
Three-phase 380V				
VFD-200G-0R7GB-T4	150W	$\geq 300\Omega$	Standard built-in	No special instructions
VFD-200G-1R5GB-T4	150W	$\geq 220\Omega$		
VFD-200G-2R2GB-T4	250W	$\geq 200\Omega$		
VFD-200G-3R7GB-T4	300W	$\geq 130\Omega$		
VFD-200G-5R5GB-T4	400W	$\geq 90\Omega$		
VFD-200G-7R5GB-T4	500W	$\geq 65\Omega$		
VFD-200G-11GB-T4	800W	$\geq 43\Omega$		
VFD-200G-15GB-T4	1000W	$\geq 32\Omega$	External	
VFD-200G-18R5G-T4	1300W	$\geq 25\Omega$		
VFD-200G-22G-T4	1500W	$\geq 22\Omega$		
VFD-200G-30G-T4	2500W	$\geq 16\Omega$		
VFD-200G-37G-T4	3.7 kW	$\geq 16.0\Omega$		
VFD-200G-45G-T4	4.5 kW	$\geq 16\Omega$		
VFD-200G-55G-T4	5.5 kW	$\geq 8\Omega$		
VFD-200G-75G-T4	7.5 kW	$\geq 8\Omega$	External	SNBU-70-B
VFD-200G-90G-T4	4.5 kW $\times 2$	$\geq 8\Omega \times 2$	External	SNBU-70-B $\times 2$
VFD-200G-110G-T4	5.5 kW $\times 2$	$\geq 8\Omega \times 2$	External	SNBU-70-B $\times 2$
VFD-200G-132G-T4	6.5 kW $\times 2$	$\geq 8\Omega \times 2$	External	SNBU-70-B $\times 2$
VFD-200G-160G-T4	16kW	$\geq 2.5\Omega$	External	SNBU-200-B
VFD-200G-200G-T4	20 kW	$\geq 2.5\Omega$	External	SNBU-200-B
VFD-200G-220G-T4	22 kW	$\geq 2.5\Omega$	External	SNBU-200-B
VFD-200G-250G-T4	12.5 kW $\times 2$	$\geq 2.5\Omega \times 2$	External	SNBU-200-B $\times 2$
VFD-200G-280G-T4	14kW $\times 2$	$\geq 2.5\Omega \times 2$	External	SNBU-200-B $\times 2$
VFD-200G-315G-T4	16kW $\times 2$	$\geq 2.5\Omega \times 2$	External	SNBU-200-B $\times 2$
VFD-200G-355G-T4	17kW $\times 2$	$\geq 2.5\Omega \times 2$	External	SNBU-200-B $\times 2$
VFD-200G-400G-T4	14 kW $\times 3$	$\geq 2.5\Omega \times 3$	External	SNBU-200-B $\times 3$

## Chapter 3 Mechanical and electrical installation

### 3.1 Mechanical installation

#### 3.1.1 Installation environment:

- 1) Environment temperature: ambient environment temperature has great influence on lifespan of frequency converter, so operating ambient temperature of frequency converter is not allowed to exceed temperature range (-10°C ~ 50°C).
- 2) Put frequency converter on surface of flame retardant object and leave enough space for heat dissipation around. Large heat produces when the frequency converter operates. Besides, install vertically on installation support with screw.
- 3) Install in the place with little vibration. Vibration shall be < 0.6G. Keep away from punch.
- 4) Avoid installing in the place with direct sunlight, humidity and dropping water, etc.
- 5) Avoid installing in the occasions with corrosive, inflammable and explosive gas in the air.
- 6) Avoid installing in the place with oil stain, dust and metal dust.

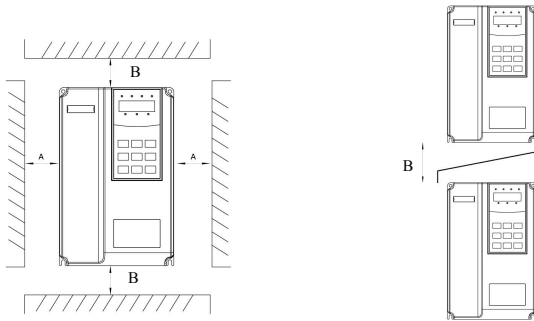

Body installation drawing

Top and bottom installation drawing

Figure 3-1 Installation diagram of VFD-200G frequency converter

Body installation: A dimension can not be considered if power of frequency converter is  $\leq 22\text{kW}$ . A shall be  $> 50\text{mm}$  if power of frequency converter is  $> 22\text{kW}$ .

Top and bottom installation: please install thermal insulation guide plate as per drawing.

Power grade	Installation dimension	
	B	A
$\leq 15\text{kW}$	$\geq 100\text{mm}$	No requirements
18.5kW—30kW	$\geq 200\text{mm}$	$\geq 50\text{mm}$
$\geq 37\text{kW}$	$\geq 300\text{mm}$	$\geq 50\text{mm}$

#### 3.1.2 Heat dissipation should be noticed for mechanical installation. Please pay attention to bellows:

- 1) Install frequency converter vertically so that heat can dissipate upward, prohibit inverting. If there are multiple frequency converters in cabinet, abreast installation is suggested. For the occasions requiring top and bottom installation, install thermal insulation guide plate as per drawing 3-1.



- 2) Installation space follows by drawing 3-1 to ensure heat dissipation space of frequency converter. Consider heat dissipation situation of other components within cabinet.
- 3) Installation bracket shall be flame retardant material.
- 4) For the occasion with metal dust, suggest installing radiator outside cabinet. The space of full sealing cabinet should be as large as possible.

3.1.3 Disassembly and installation of lower cover plate

VFD-200G series frequency converter <18.5kW adopts plastic shell. The disassembly of lower cover plate of plastic shell refers to figure 3-2, 3-3. Push out hook of lower cover plate from inside with tool.

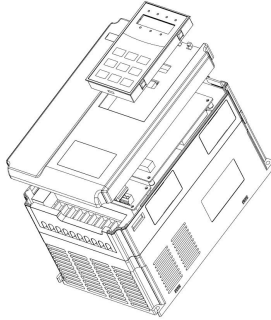

Figure 3-2 Disassembly drawing of lower cover plate of plastic shell

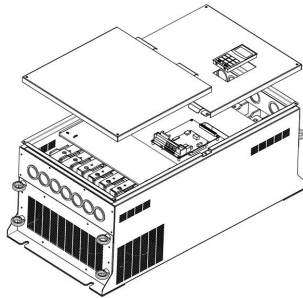



Figure 3-3 Disassembly drawing of lower cover plate of metal plate shell

VFD-200G series frequency converter >18.5kW adopts metal plate shell. The disassembly of lower cover plate of metal plate shell refers to figure 3-3. Unscrew the screw on lower cover plate directly with tool.

 Danger
● When disassembling lower cover plate, avoid falling plate from injury to device and body.

3.2 Electrical installation

3.2.1 Model selection guidance of periphery electrical components

Figure 3-1 Model selection guidance of periphery electrical components for VFD-200G frequency converter

Model of frequency converter	(MCCB) A	Recommend contactor A	Major loop wiring on input side mm <sup>2</sup>	Major loop wiring on output side mm <sup>2</sup>	Recommend control loop wiring mm <sup>2</sup>
Single-phase 220V					
VFD-200G-0R4GB-S2	16	10	2.5	2.5	1.0
VFD-200G-0R7GB-S2	16	10	2.5	2.5	1.0
VFD-200G-1R5GB-S2	20	16	4.0	2.5	1.0
VFD-200G-2R2GB-S2	32	20	6.0	4.0	1.0
Three-phase 220V					
VFD-200G-0R4GB-T2	10	10	2.5	2.5	1.0
VFD-200G-0R7GB-T2	16	10	2.5	2.5	1.0
VFD-200G-1R1GB-T2	16	10	2.5	2.5	1.0
VFD-200G-2R2GB-T2	25	16	4.0	4.0	1.0
VFD-200G-3R7GB-T2	32	25	4.0	4.0	1.0
VFD-200G-5R5GB-T2	63	40	4.0	4.0	1.0
VFD-200G-7R5GB-T2	63	40	6.0	6.0	1.0
VFD-200G-11G-T2	100	63	10	10	1.5
VFD-200G-15G-T2	125	100	16	10	1.5
VFD-200G-18R5G-T2	160	100	16	16	1.5
VFD-200G-22G-T2	200	125	25	25	1.5
VFD-200G-30G-T2	200	125	35	25	1.5
VFD-200G-37G-T2	250	160	50	35	1.5
VFD-200G-45G-T2	250	160	70	35	1.5
VFD-200G-55G-T2	350	350	120	120	1.5
VFD-200G-75G-T2	500	400	185	185	1.5
Three-phase 380V					
VFD-200G-0R7GB-T4	10	10	2.5	2.5	1.0
VFD-200G-1R5GB-T4	16	10	2.5	2.5	1.0
VFD-200G-2R2GB-T4	16	10	2.5	2.5	1.0
VFD-200G-3R7GB-T4	25	16	4.0	4.0	1.0
VFD-200G-5R5GB-T4 VFD-200G-7R5PB-T4	32	25	4.0	4.0	1.0
VFD-200G-7R5GB-T4 VFD-200G-11 PB-T4	40	32	4.0	4.0	1.0
VFD-200G-11 GB-T4 VFD-200G-15PB-T4	63	40	4.0	4.0	1.0
VFD-200G-15GB-T4 VFD-200G-18R5PB-T4	63	40	6.0	6.0	1.0
VFD-200G-18R5G-T4 VFD-200G-22P-T4	100	63	6	6	1.5
VFD-200G-22G-T4 VFD-200G-30P-T4	100	63	10	10	1.5
VFD-200G-30G-T4 VFD-200G-37P-T4	125	100	16	10	1.5

Specification of VFD-200G high-performance vector converter Mechanical and electrical installation

Model of frequency converter	(MCCB) A	Recommend contactor A	Major loop wiring on input side mm <sup>2</sup>	Major loop wiring on output side mm <sup>2</sup>	Recommend control loop wiring mm <sup>2</sup>
VFD-200G-37G-T4 VFD-200G-45P-T4	160	100	16	16	1.5
VFD-200G-45G-T4 VFD-200G-55P-T4	200	125	25	25	1.5
VFD-200G-55G-T4 VFD-200G-75P-T4	200	125	35	25	1.5
VFD-200G-75G-T4 VFD-200G-90P-T4	250	160	50	35	1.5
VFD-200G-90G-T4 VFD-200G-110P-T4	250	160	70	35	1.5
VFD-200G-110G-T4 VFD-200G-132P-T4	350	350	120	120	1.5
VFD-200G-132G-T4 VFD-200G-160P-T4	400	400	150	150	1.5
VFD-200G-160G-T4 VFD-200G-200P-T4	500	400	185	185	1.5
VFD-200G-200G-T4 VFD-200G-220P-T4	600	600	150*2	150*2	1.5
VFD-200G-220G-T4 VFD-200G-250P-T4	600	600	150*2	150*2	1.5
VFD-200G-250G-T4 VFD-200G-280P-T4	800	600	185*2	185*2	1.5
VFD-200G-280G-T4 VFD-200G-315P-T4	800	800	185*2	185*2	1.5
VFD-200G-315G-T4 VFD-200G-355P-T4	800	800	150*3	150*3	1.5
VFD-200G-355G-T4 VFD-200G-400P-T4	800	800	150*4	150*4	1.5
VFD-200G-400G-T4 VFD-200G-450P-T4	1000	1000	150*4	150*4	1.5

### 3.2.2 Instructions of peripheral electrical components

Figure 3-2 Instructions of peripheral electrical components for VFD-200G frequency converter

Part name	Installing	Functional description
Air switch	Front of input circuit	Break power if any overcurrent of downstream equipment
Contactor	Input side of air switch and converter	Turn on/off power of converter. Avoid frequent on/off operation of converter through contactor (< twice every minute) or starting operation directly
AC input reactor	Input side of converter	Promote power factor on input side; eliminate higher harmonic on input side and prevent device damage caused by voltage waveform distortion; eliminate unbalanced input current caused by unbalance between power phase
EMC input filter	Input side of converter	Reduce external conduction and radiated interference of converter; reduce conduction interference from power end to converter, promote antijamming capability of converter
DC reactor	DC bus side of converter	Promote power factor on input side; enhance efficiency and heat stability of converter. Eliminate influence of higher harmonic on input side on converter, reduce external conduction and radiated interference
AC output reactor	Between output side of converter and motor. Install near frequency converter	Output side of converter contains much higher harmonic. If motor is far away from converter, much distributed capacitance exists in circuit. Certain harmonic may produce resonance in circuit, which will damage insulating property of motor and even motor, produce large leak current and cause frequent protection of converter. The distance between converter and motor generally exceeds 50m, suggest installing output AC reactor

3.2.3 Wiring way

Wiring diagram of frequency converter:

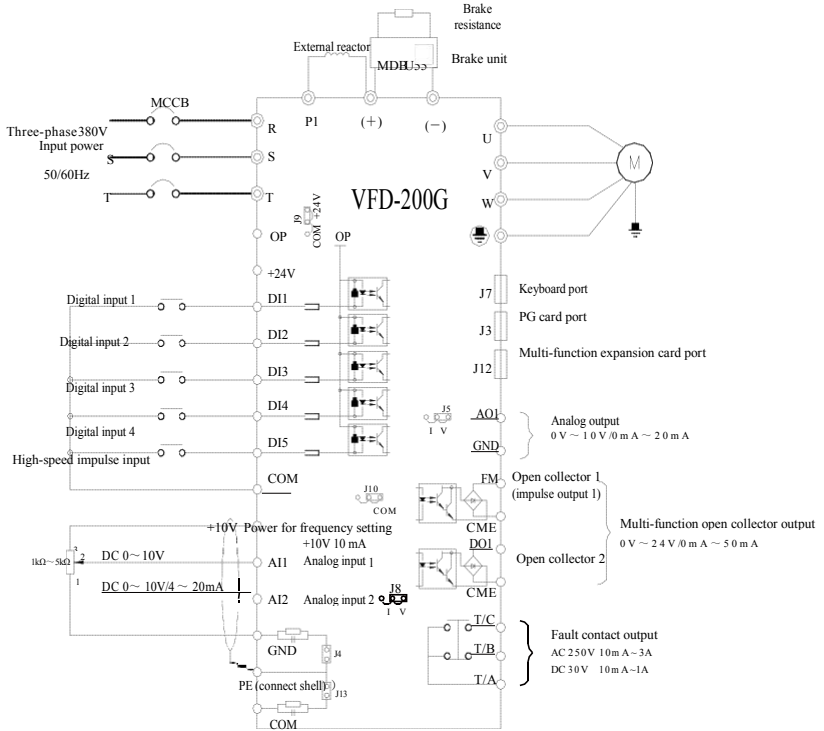

Figure 3-4 Wiring diagram of frequency converter

Precautions:

- 1) Ⓞ refers to terminal of major loop, ○ refers to terminal of control loop.
- 2) Brake resistance needs to be selected based on user demands, see more details in model selection guidance of brake resistance.

3.2.4 Terminal and wiring of main circuit

1) Description of terminal of main circuit for single-phase frequency convertor

Terminal marking	Name	Description
L1, L2	Input terminal of single-phase power	Contact poin of single-phase 220V AC power
(+), (-)	Positive/negative terminals of DC bus	Input point of DC bus
(+), PB	Connection terminal of brake resistance	Connect brake resistance
U, V, W	Output terminal of convertor	Connect three-phase motor
PE $\oplus$	Earthing terminal	Earthing terminal

2) Description of terminal of main circuit for single-phase frequency convertor

Terminal marking	Name	Description
R, S, T	Input terminal of three-phase power	Connection point of AC input three-phase power
(+), (-)	Positive/negative terminals of DC bus	Input point of DC bus and brake unit
(+), PB	Connection terminal of brake resistance	Connect brake resistance
P1, (+)	Connection terminal of external DC reactor	Connection point of external DC reactor
U, V, W	Output terminal of convertor	Connect three-phase motor
PE $\oplus$	Earthing terminal	Earthing terminal

Wiring precautions:

- a) Input power L1, L2 or R, S, T:
- b) Wiring on input side of convertor has no requirement on phase sequence. Wiring precautions:

1: (+) (-) terminals of DC bus: there's residual voltage for DC bus (+) (-) immediately after outage. Contact after CHARGE light extinguishes and confirm it's <36V, otherwise there is risk of electric shock.

2: When selecting external braking component, avoid inverse connection of (+) (-) polarity, otherwise it will lead to damage of frequency convertor and even fire.

3: Wiring length of brake unit should not exceed 10m. Twisted pair or tight double-line should be used for parallel wiring. Do not connect brake resistance directly to DC bus, otherwise it will lead to damage of frequency convertor and even fire.

- c) Connection terminal (+), PB of brake resistance:

Confirm the model of built-in brake unit, and connection terminal of brake resistance is valid.

Model selection of brake resistance refers to recommended value and wiring distance should be <5m, otherwise frequency convertor may be damaged.

d) Connection terminal P1, (+) of external DC reactor

For the frequency converter at above 220V37KW and 380V75kW, connection strap between P1 and (+) terminals needs to be removed when installing DC reactor externally, and connect DC reactor between two terminals.

e) U, V, W on output side of frequency converter: output side of frequency converter shall not connect capacitor or surge absorber, otherwise it will lead to frequent protection and even damage of converter. Due to influence of distributed capacitance, if motor cable is too long, electric resonance will produce easily, which will damage motor insulation or produce large leak current and frequent protection of converter. If motor cable is >100m, AC input reactor should be installed.

f) Earthing terminal PE (⊕)

For different models, the marking of earthing terminal may be different, but the meaning is same. In above descriptions, PE (⊕) means that earthing marking is PE or (⊕). Keep reliable earthing of earthing terminal and resistance value of ground wire should be <0.1Ω, otherwise it will lead to abnormal operation and even damage of device. Do not use earthing terminal PE or (⊕) and N terminal on null line of power in common.

3.2.5 Control terminal and wiring

1) Layout diagram of terminals on control circuit is as below:

(Note: there's no short-circuit strap between CME and COM, OP and +24V of VFD-200G frequency converter. Users select wiring way of CME and OP respectively through J10, J9)

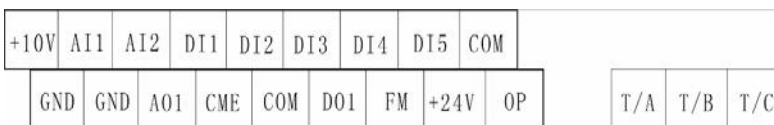

Figure 3-5 Layout diagram of terminals on control circuit

2) Functional descriptions of control terminals

Figure 3-3 Functional descriptions of control terminals of VFD-200G frequency converter

Type	Terminal symbol	Terminal name	Functional description
Power	+10V-GND	Connect +10V power externally	Offer +10V power externally, max. output current: 10mA Be commonly used as working power of external potentiometer, resistance value range of potentiometer: 1kΩ~5kΩ
	+24V-COM	Connect +24V power externally	Offer +24V power externally, be used as working power of digital input/output terminal and power of external sensor Max. output current: 200mA
	OP	Input terminal of external power	Connect +24V or COM through J9 jumper on control panel. If using external signal to drive DI1~DI5, OP needs to connect with external power, and pull out J9 jumper
Analog input	AI1-GND	Analog input terminal 1	1. Range of input voltage: DC 0V~10V 2. Input impedance: 22kΩ
	AI2-GND	Analog input terminal 2	1. Input range: DC 0V~10V/4mA~20mA, depend on J8 jumper on control panel 2. Input impedance: 22kΩ for voltage input, 500Ω for current input

Type	Terminal symbol	Terminal name	Functional description
Digital input	DI1- OP	Digital input 1	1. Optical coupling isolation, be compatible with bipolar input 2. Input impedance: 2.4kΩ 3. Voltage range for level input: 9V~30V
	DI2- OP	Digital input 2	
	DI3- OP	Digital input 3	
	DI4- OP	Digital input 4	
		DI5- OP	High-speed impulse input terminal
Analog output	AO1-GND	Analog output 1	J5 jumper on control panel decides voltage or current output. Output voltage range: 0V~10V Output current range:0mA~20mA
Digital output	DO1-CME	Digital output 1	Optical coupling isolation, bipolar open collector output Output voltage range: 0V~24V; output current range: 0mA~50mA Caution: digital output CME and digital input COM are internally isolated, but short circuit of CME and COM is realized through J10 jumper on control panel (DO1 is +24V drive by default). If DO1 needs to be driven by external power, pull out J10 jumper
	FM- CME	High-speed impulse output	Be restricted by function code F5-00 “output way selection of FM terminal” As high-speed impulse output, max. frequency is 100kHz As open-collector output, it’s the same with DO1 specification
Relay output	T/A-T/B	Normally closed terminal	Drive capability of contact: AC250V, 3A, COSφ=0.4 DC 30V, 1A
	T/A-T/C	Normally open terminal	

3) Functional description of jumper and auxiliary terminals

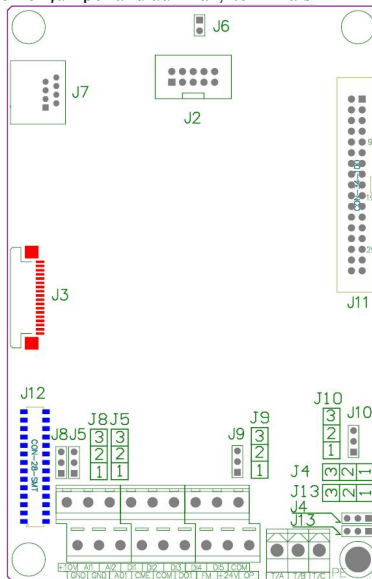

Figure 3-6 Location diagram of jumper and auxiliary terminals

Figure 3-4 Functional description of jumper and auxiliary terminals for VFD-200G frequency converter

Jumper marking		Name	Description
Auxiliary terminal	J12	Multi-function expansion card port	28-core terminal, connect with optional cards (I/O expansion card, PLC card, various bus cards, etc)
	J3	PG card port	Optional: OC, differentiation, rotary transformer, etc
	J7	External keyboard port	External keyboard
Jumper	J4	Select jumper to connect PE and GND	Select if PE connects with GND. In the occasion with interference, connect PE with GND to enhance anti-interference. Connection by default. (As shown in Figure 3-6, short circuit of 1-2 is connection between PE and GND, short circuit of 2-3 is no connection between PE and GND)
	J13	Select jumper to connect PE and COM	Select if PE connects with COM. In the occasion with interference, connect PE with COM to enhance anti-interference. Connection by default. (As shown in Figure 3-6, short circuit of 1-2 is connection between PE and COM, short circuit of 2-3 is no connection between PE and COM)
	J10	Select jumper to connect CME and COM	Select if CME connects with COM. No connection by default. (As shown in Figure 3-6, short circuit of 1-2 is connection between CME and COM, short circuit of 2-3 is no connection between CME and COM)
	J5	AO1 analog output selection	Decide output type of analog output terminal AO1 is voltage or current output. Voltage output by default. (As shown in Figure 3-6, short circuit of 1-2 is voltage output, short circuit of 2-3 is current output) Output voltage range: 0V-10V Output current range: 0mA -20mA
	J8	AI2 analog input selection	Decide input type of analog input terminal AO1 is voltage or current input. Voltage input by default. (As shown in Figure 3-6, short circuit of 1-2 is voltage input, short circuit of 2-3 is current input) Input voltage range: DC 0V-10V Input current range: 0mA -20mA
	J9	Connection selection of OP terminal	OP terminal connects +24V or COM through J9 jumper. +24V connection by default. (As shown in Figure 3-6, short circuit of 1-2 is OP and +24V connection, short circuit of 2-3 is OP and COM connection) If using external signal to drive DI1~DI5, OP needs to connect with external power, and pull out J9 jumper

4) Wiring description of control terminals

a) Analog input terminal:

Due to weak analog voltage signal, it's easily influenced by external interference, shield cable is commonly used and wiring distance is as short as possible, which should not exceed 20m as shown in Figure 3-7. In the occasion where certain analog signal is seriously interfered, the side of analog signal source should be installed with filter capacitor or ferrite core as shown in Figure 3-7.



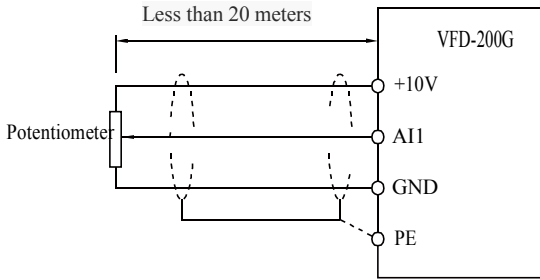

Figure 3-7 Wiring diagram of analog input terminal

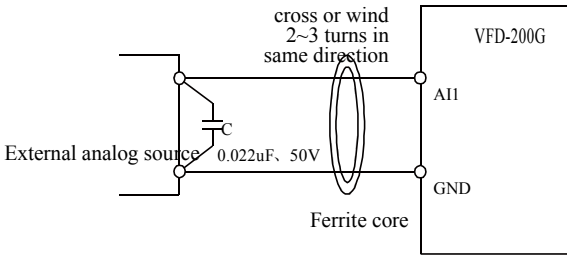

Figure 3-8 Treatment wiring diagram of analog input terminal

b) Digital input terminal: wiring method of DI terminal

Shield cable is commonly used and wiring distance is as short as possible, which should not exceed 20m. If using active way to drive, necessary smoothing measures should be adopted for crosstalk of power. It's suggested to use contactor control way.

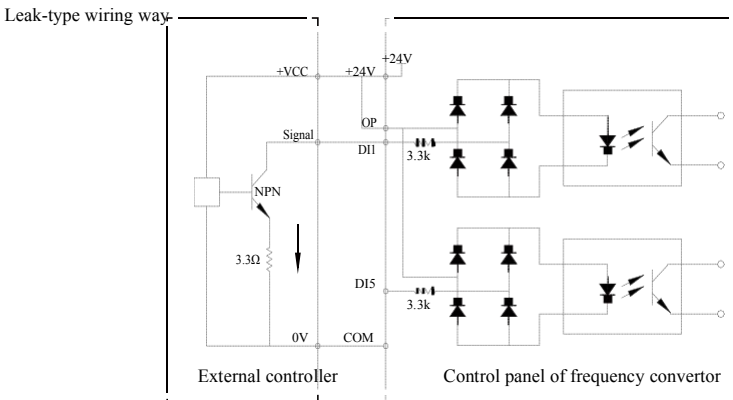

Figure 3-9 Leak-type wiring way

This is the commonest wiring way. If using external power, pull out jumper J9 between +24V and OP, connect positive pole of external power to OP and negative pole of external power to CME.

Source-type wiring way

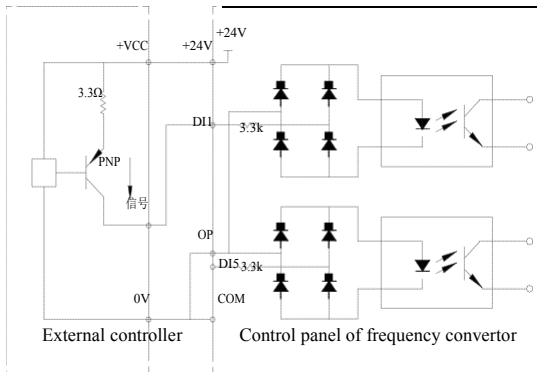

Figure 3-10 Source-type wiring way

This kind of wiring way needs to jump OP of jumper J9 to COM, connect +24V to common port of external controller. If using external power, connect negative pole of external power to OP.

c) DO digital output terminal: if digital output terminal needs to drive relay, absorber diode should be installed on two sides of relay coil, otherwise DC 24V power may be damaged.

Caution: install the polarity of absorber diode correctly as shown in Figure 3-11. Otherwise, if any output of digital output terminal, it will damage DC 24V power immediately.

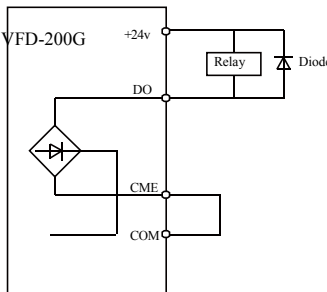

Figure 3-11 Wiring diagram of digital output terminal

## Chapter 4 Operation and Display

### 4.1 Interface introductions of operation and display

The operating panel can modify the function parameters of frequency converter, monitor the working status of the frequency converter, control the running of the frequency converter (start, halt), etc. The exterior and function area are shown as below:

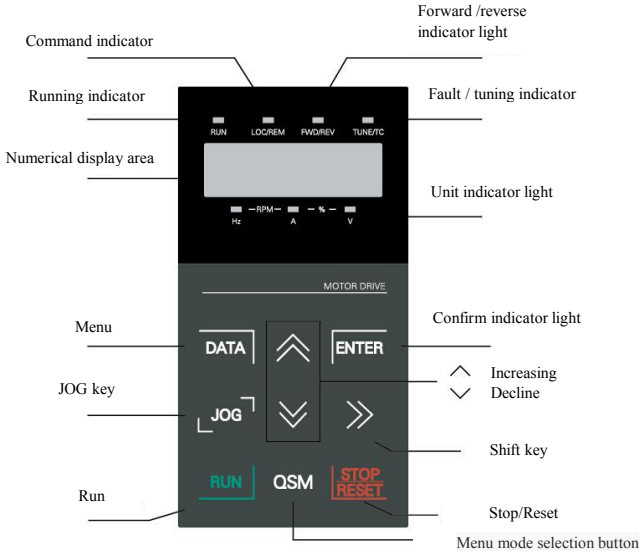

Figure 4-1 Schematic diagram of operation panel

#### 1) Instructions of function indicator light:

**RUN:** When the light is off, it means the converter is in halt state. When the light is bright, it means the converter is in running state.

**LOCAL / REMOT:** Keyboard operation, terminal operation and remote operation (communication control) indicating light. When the light is off, it means the keyboard operation control state. If the light is bright, it means terminal operation control state. If the light flickers, it means it is in remote control state.

**FWD / REV:** Reversing light, when the light is bright it means it is in normal running state.

**TUNE / TC:** Tune / Torque Control / Fault Indicating Lamp, bright light means it is in torque control mode. Slow flickering light means it is in tune state. Fast flickering light means it is in fault state.

#### 2) Unit indicator light:

Hz: frequency unit      A: current unit      V: voltage unit

RMP (Hz+A) Rotate speed unit % (A+V)      Percentage

#### 3) Digital display:

5-bit LED display displays setting frequency, output frequency, kinds of monitoring data and warning code, etc.

#### 4) Instructions of keyboard button

Table 4-1 Keyboard function

Key	Name	Function
DATA	Programming key	Enter or exit first-level menu
ENTER	Enter key	Enter menu step-by-step, set parameters and confirm them
△	Increasing key	Incremental data or function code
▽	Decreasing key	Decrement data or function code
▷	Shift key	In the stop display interface and running display interface, you can cycle through display parameters; when modifying parameters, you can modify the parameters of the bit
RUN	Running key	In keyboard mode, used to run the operation
STOP/REST	Stop / Reset	When running, press this button can be used to stop the operation; fault alarm state, it can be used to reset the key features that restrict the function code P7-02
QSM	Menu mode selection key	Function switch based on PP-03
JOG	Jog Key	Function switch based on P7-01, defined as command source or quickly switch direction

#### 4.2 Viewing and modifying methods of function code

Operation panel VFD-200G frequency converter adopts three-level menu structure for parameter settings and other operations. Three-level menus are: function parameter group (first level)→function code (second level)→function code setting (second level). Operational flow is shown in Figure 4-2.

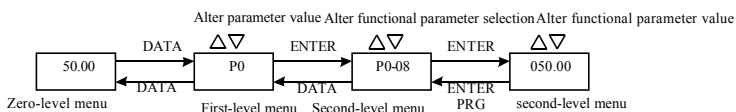
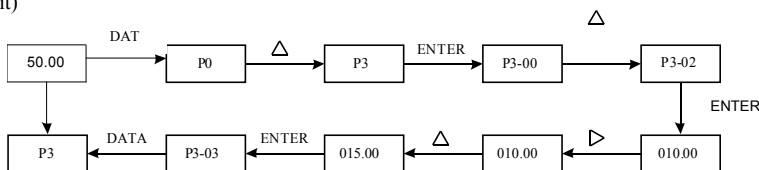

Figure 4-2 Flow chart of three-level menus

Instructions: when operating second-level menu, press the DATA key or ENTER key to return to the second-level menu. The difference is: press ENTER to save the setup parameter and return to the second-level menu, and then automatically shift to the next function code; press the SET key will directly return to the second-level menu without saving the parameters, and return to the current function code.

Example: the function code P3-02 is set to change from 10.00Hz 15.00Hz. (Bold text indicates the flashing bit)



Under status of second-level menu, if there is no flashing bit for parameters, the function code can't be modified, and the possible reasons are below:

- 1) The function code is parameter that can't be modified, such as actual detection parameter and operation record parameter, etc.
- 2) The function code can't be modified under running status, and it can only be modified after halting.

### 4.3 Parameter display mode

Parameter display mode is mainly set for users to view functional parameters with different spread patterns based on actual demand, and there are three parameter display modes.

Name	Description
Functional parameter mode	Display functional parameters of frequency converter in order, including P0~PF, A0~AF, U0~UF functional parameter
User-defined parameter mode	User-defined functional parameters (define 32 parameters at most), users can confirm functional parameters to be displayed through PE group
User-modified parameter mode	Functional parameters being not consistent with factor default

Related functional parameters are PP-02 and PP-03 as below:

PP-02	Functional parameter mode display property	Factory default	11
	Setting range	Unit	U group display selection
		0	Not display
		1	Display
		Decade	A group display selection
		0	Not display
1		Display	
PP-03	Defined parameter mode display selection	Factory default	00
	Setting range	Unit	User-defined parameter display selection
		0	Not display
		1	Display
		Decade	User-modified parameter display selection
		0	Not display
1		Display	

If defined parameter mode display selection (PP-03) exists to be one display, different parameter display modes can be switched through QSM key.

Display code of each parameter display mode is as below:

Parameter display mode	Display
Functional parameter mode	- b A S E
User-defined parameter mode	- 1 1 9 F r
User-modified parameter mode	- - [ - -

Switching mode is as follows:

The current way for function parameters, switch to a custom parameters

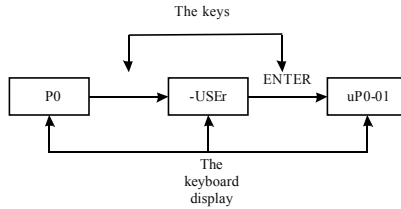

#### 4.4 user customization parameters

The establishment of the user's customized menu is mainly to facilitate users to view and modify the commonly used functional parameters. The parameters of customized menu display in the form of "uP3-02", it is said that the function of parameter P3-02 in the custom menu to modify the parameters and modify the parameters of the effect of the corresponding programming in general condition is the same.

User customized menu function parameters from the PE group, by the PE group to select the functional parameters, set to P0-00 is not selected

Choose, can be set to 30; if the menu when the display "NULL", which means that the user to customize the menu.

When the initial user custom menu has been deposited in the commonly used 16 parameters to facilitate the user to use:

- P0-01: control mode                      P0-02: command source selection
- P0-03: dominant frequency source selection      P0-07: frequency source selection
- P0-08: preset frequency                      P0-17: acceleration time
- P0-18: deceleration time                      P3-00: V/F curve setting
- P3-01: torque boost                      P4-00: DI1 terminal function selection
- P4-01: DI2 terminal function selection      P4-02: DI3 terminal function selection
- P5-04: DO1 output selection                      P5-07: AO1 output selection
- P6-00: start mode                      P6-10: stop mode

Users can according to their own specific needs to be customized for the user to edit.

#### 4.5 Method for viewing state parameter

Under the outage or running state , Through the shift key“ $\Delta$ ”Can display a variety of state parameter, respectively. By the function code P7-03 (running parameters 1), P7-04 (operation parameters 2), P7-05 (parameters) downtime by binary bit choose whether to display the parameters.

In stop state, with a total of 16 parameters can choose whether show stop condition respectively: set frequency, bus electric pressure, DI input state, the DO output state, voltage analog input AI1, AI2 analog input voltage, the analog input voltage AI3, actual count value, the actual length value, PLC operation step, load speed display, PID setting, PULSE input PULSE frequency and three reserve parameters, switch input sequences show that the selected parameters.

In running state, the running state of the five parameters: Operating frequency, set frequency, busbar voltage, output voltage, output current for the default display, other display parameters: Output power, output torque, DI input state, the DO output state, voltage analog input AI1, AI2 analog input voltage, the analog input voltage AI3, actual count value, the actual length value, linear velocity, PID, PID feedback is displayed by the function code P7-03, P7-04 bitwise (converted to binary) selection, switch input sequences show that the selected parameters.

Inverter power again to electricity, the display parameter is the default for inverter power lost before the choice of parameters.

4.6 Password settings

Frequency converter provides the user password protection function, when the PP - 00 is set to zero, is the user's password, exit function code editor state password protection is effective, once again, press the DATA, will show "-- -- -- -- --", input user password must be correct, can enter ordinary menu, otherwise unable to enter.

If you want to cancel the password protection function, it is only through the password to enter, and PP - 00 to 0.

4.7 Automatic tuning of motor parameters

Choose the vector control operation mode, in front of the frequency converter operation, must be accurate input motor nameplate parameters, VFD-200G frequency converter on the basis of standard motor nameplate parameters matching parameters; Vector control method of motor parameters dependence is very strong, to get good control performance, must be charged with the accurate parameters of the machine.

Motor parameters automatic tuning steps are as follows:

Will first command source (P0-02) choice for operation panel command channel. Then please click the parameters of the motor under the actual parameter input (according to the current motor choice) :

Motor selection	parameter
Motor 1	P1-00: motor type selection P1-01: motor rated power P1-02: motor rated voltage P1-03: the motor rated current P1-04: motor rated frequency P1-05: motor rated speed
Motor 2	A2-00: motor types to choose A2-01: motor rated power A2-02: motor rated voltage A2-03: the motor rated current A2-04: A2-05: motor rated frequency motor rated speed

If the motor can be completely off load, and then the P1-37 (motor 2 A2 \ to 37) please select 2 (asynchronous machine complete tuning), and then press the RUN key on the keyboard panel, the inverter will automatically calculate the motor of the following parameters:

Motor selection	parameter
Motor 1	P1-06: synchronous machine stator resistance P1-07: synchronous machine D axis inductance P1-08: synchro Q axis inductance P1-09: mutual inductance of the asynchronous motor P1-10: asynchronous motor no-load current
Motor 2	A2-06: synchronous machine stator resistance A2-07: synchronous machine D axis inductance A2-08: synchro Q axis inductance A1-09: mutual inductance of the asynchronous motor A1-10: asynchronous motor no-load current

The motor parameters are automatically tuned.

If the motor and the load can not be completely torn off, then P1-37 (motor 2 A2-37) select 1 (asynchronous machine, static tuning) and then press the RUN key on the keyboard panel

## Chapter 5 Functional parameter table

PP-00 is set to be non-zero value, namely setting the parameter protection password. Under mode of functional parameter and user-modified parameter, the parameter menu can only be accessed after entering correct password. To cancel the password, PP-00 needs to be set as 0.

Parameter menu under mode of user-modified parameter is not protected with password. P group and A group are basic function parameters, U group is monitoring parameter. The symbols in functional table are as follows:

“☆”: It indicates the set value of the parameter can be changed under halt and running status of frequency converter;

“★”: It indicates the set value of the parameter can not be changed under running status of frequency converter;

“●”: It indicates the value of this parameter is the actually measured value and can not be changed;

“\*”: It indicates that the parameter is “factory default” and can only be set by the manufacturer, and users are prohibited to operate;

Table of basic functional parameters

Code	Name	Setting range	Default	Change
<b>P0 basic function group</b>				
P0-00	G / P Display type	1: G Type (Constant torque load model) 2: P Type (Fan and pump load model)	Depend on machine type	●
P0-01	1 <sup>st</sup> motor control mode	0: No speed Sensor vector control (SVC) 1: Speed sensor vector control (FVC) 2: V / F control	0	★
P0-02	Command source selection	0: Operation panel CMD channel (LED off) 1: Terminal CMD channel (LED lights) 2: Cmd channel (LED flashes)	0	☆
P0-03	Main frequency source X selection	0: Digital setting (Preset frequency P0-08, UP / DOWN can be modified, memory after power failure) 1: Digital setting (Preset frequency P0-08, UP / DOWN can be modified, no memory after power failure) 2: AI1 3: AI2 4: AI3 5: PULSE setting (DI5) 6: Multi-stage command 7: Simple PLC 8: PID 9: Communication given	0	★
P0-04	Auxiliary frequency source Y selection	Same as P0-03 (Main frequency source X selection)	0	★
P0-05	Auxiliary superimposed frequency source Y range selection	0 : Relative to the maximum frequency 1 : Relative to frequency source X	0	☆
P0-06	Auxiliary superimposed frequency source Y range selection	0%~150%	100%	☆
Code	Name	Setting range	Default	Change



P0-07	Frequency source superimposed selection	Bits: Frequency source selection 0: Main frequency source X 1: Main and auxiliary operation result (Operation relation depends on decimal) 2: Switch of main frequency source X and auxiliary frequency source Y 3: Main frequency source X, main and auxiliary operation result switch 4: Auxiliary frequency source Y, main and auxiliary operation result switch Decimal: operation relation of main and auxiliary frequency source 0: Main + auxiliary 1: Main-auxiliary 2: Max. of the two 3: Min. of the two	00	☆
P0-08	Preset frequency	0.00Hz~maximum frequency (P0-10)	50.00Hz	☆
P0-09	Running direction	0 : Same direction 1 : Opposite direction	0	☆
P0-10	Maximum frequency	50.00Hz~600.00Hz	50.00Hz	★
P0-11	Upper frequency source	0: P0-12 setting 1: AI1; 2: AI2; 3: AI3; 4: PULSE setting 5: Communication given	0	★
P0-12	Upper frequency	Upper frequency P0-14~maximum frequency P0-10	50.00Hz	☆
P0-13	Upper frequency offset	0.00Hz~maximum frequency P0-10	0.00Hz	☆
P0-14	Lower frequency	0.00Hz~upper frequency P0-12	0.00Hz	☆
P0-15	Carrier frequency	0.5kHz~16.0kHz	machine type	☆
P0-16	carrier frequency adjusts with temperature	0: no 1: yes	1	☆
P0-17	Acceleration time 1	0.00s~65000s	machine type	☆
P0-18	Deceleration time 1	0.00s~65000s	machine type	☆
P0-19	Acceleration/Deceleration time unit	0: 1s 1: 0.1s 2: 0.01s	1	★
P0-21	Auxiliary superimposed frequency source bias frequency	0.00Hz~maximum frequency P0-10	0.00Hz	☆
P0-22	Resolution frequency command	1: 0.1Hz 2: 0.01Hz	2	★
P0-23	Digital setting frequency stop memory selection	0: no memory 1: memory	0	☆
P0-24	Motor selection	0: Motor 1, 1: Motor 2	0	★
P0-25	Acceleration/Deceleration time reference frequencies	0: maximum frequency (P0-10) 1: Set frequency 2: 100Hz	0	★
P0-26	Frequency command in operation UP/DOWN standard	0: Operating frequency, 1: Set frequency	0	★
Code	Name	Setting range	Default	Change

P0-27	Frequency source and command source in bundle	Bits: operation panel command binds frequency source 0: Unbound 1: Digital set frequency 2: AI1 3: AI2 4: AI3 5: PULSE setting (DI5) 6: Multispeed 7: Simple PLC 8: PID 9: Communication given Ten bits: terminal command binds frequency source Hundred bits: communication command binds frequency source Thousand bits: automatical operation binds frequency source	0000	☆
P0-28	Communication expansion card type	0: Modbus communication card 1: Spare 2: Spare 3: CANlink communication card	0	☆
Parameter of 1 <sup>st</sup> motor in P1 group				
P1-00	Type selection of motor	0: common asynchronous motor 1: variable frequency asynchronous motor	0	★
P1-01	Rated power of motor	0.1kW~1000.0kW	machine type	★
P1-02	Rated voltage of motor	1V~400V	machine type	★
P1-03	Rated current of motor	0.01A~655.35A (converter power <=55kW) 0.1A~6553.5A (converter power >55kW)	machine type	★
P1-04	Rated frequency of motor	0.01Hz~max. frequency	machine type	★
P1-05	Rated speed of motor	1rpm~6553rpm	machine type	★
P1-06	Stator resistance of asynchronous motor	0.001Ω~65.535Ω (converter power <=55kW) 0.0001Ω~6.5535Ω (converter power >55kW)	Tuning	★
P1-07	Rotor resistance of asynchronous motor	0.001Ω~65.535Ω (converter power <=55kW) 0.0001Ω~6.5535Ω (converter power >55kW)	Tuning	★
P1-08	Leakage inductive reactance of asynchronous motor	0.01mH~655.35mH (converter power <=55kW) 0.001mH~65.535mH (converter power >55kW)	Tuning parameter	★
P1-09	Mutual inductive reactance of asynchronous motor	0.1mH~6553.5mH (converter power <=55kW) 0.01mH~655.35mH (converter power >55kW)	Tuning parameter	★
P1-10	No-load current of asynchronous motor	0.01A~P1-03 (converter power <=55kW) 0.1A~P1-03 (converter power >55kW)	Tuning parameter	★
Code	Name	Setting range	Default	Change

P1-27	Encoder line number	1~65535	1024	★
P1-28	Encoder type	0: ABZ incremental encoder 1: Spare 2: Rotary transformer	0	★
P1-30	ABZ incremental encoder AB phase sequence	0: Forward 1: Reverse	0	★
P1-34	Pole-pairs number of rotary transformer	1~65535	1	★
P1-36	Speed feedback PG disconnection detection time	0.0: no action 0.1s~10.0s	0.0	★
F1-37	Tuning selection	0: No operation 1: Static tuning of asynchronous motor 2: Complete tuning of asynchronous motor	0	★
Vector control parameters of 1 <sup>st</sup> motor in P2 group				
P2-00	Speed loop proportional gain 1	1~100	30	☆
P2-01	Speed loop integral time 1	0.01s~10.00s	0.50s	☆
P2-02	Switching frequency 1	0.00~P2-05	5.00Hz	☆
P2-03	Speed loop proportional gain 2	1~100	20	☆
P2-04	Speed loop integral time 2	0.01s~10.00s	1.00s	☆
P2-05	Switching frequency 2	P2-02~max. frequency	10.00Hz	☆
P2-06	Vector control slip gain	50%~200%	100%	☆
P2-07	Speed loop filter time constant	0.000s~0.100s	0.000s	☆
P2-08	Vector control over excitation gain	0~200	64	☆
P2-09	Upper limit source under speed control mode	0: Setting of function code P 2-10 1: AI1 2: AI2 3: AI3 4: PULSE setting 5 : Communication given 6 : MIN (AI1, AI2) 7 : MAX (AI1, AI2) Full scale of 1-7 option correspond to P2-10	0	☆
P2-10	Digital setting of torque under speed control mode	0.0%~200.0%	150.0%	☆
P2-13	Excitation proportional gain	0~60000	2000	☆
P2-14	Excitation integral gain	0~60000	1300	☆
P2-15	Torque control proportional gain	0~60000	2000	☆
Code	Name	Setting range	Default	Change

P2-16	Torque control integral gain	0~60000	1300	☆
V/F control parameters in P3 group				
P3-00	V/F curve setting	0 : Straight line V/F 1 : Multipoint V/F 2 : Square V/F 3 : 1.2 power V/F 4 : 1.4 power V/F 6 : 1.6 power V/F 8 : 1.8 power V/F 9: Reserve 10 : VF complete separation mode 11 : VF semi-separation mode	0	★
P3-01	Torque boost	0.0% : (Automatic torque boost) 0.1%~30.0%	machine type	☆
P3-02	Cut-off frequency of torque boost	0.00Hz~max. frequency	50.00Hz	★
P3-03	Multi-point VF frequency point 1	0.00Hz~P3-05	0.00Hz	★
P3-04	Multi-point VF voltage point 1	0.0%~100.0%	0.0%	★
P3-05	Multi-point VF frequency point 2	P3-03~P3-07	0.00Hz	★
P3-06	Multi-point VF voltage point 2	0.0%~100.0%	0.0%	★
P3-07	Multi-point VF frequency point 3	P3-05~rated frequency of motor (P1-04)	0.00Hz	★
P3-08	Multi-point VF voltage point 3	0.0%~100.0%	0.0%	★
P3-09	V/F slip compensation gain	0.0%~200.0%	0.0%	☆
P3-10	V/F over excitation gain	0~200	64	☆
P3-11	V/F oscillation suppression gain	0~100	machine type	☆
P3-13	V/F isolated voltage source	0 : Digital setting (P3-14) 1: AI1 2: AI2 3: AI3 4: PULSE setting (DI5) 5 : Multi-stage command 6 : Simple PLC 7: PID 8 : Communication given Note: 100.0% correspond to the motor rated voltage	0	☆
P3-14	V/F isolated digital voltage setting	0V~rated voltage of motor	0V	☆
P3-15	V/F isolated voltage rise time	0.0s~1000.0s Note: time for 0V changes to rated voltage of motor	0.0s	☆

Code	Name	Setting range	Default	Change
Input terminal of P4 group				
P4-00	Function selection of DI1 terminal	0: No function 1: Forward running (FWD) 2: Reverse running (REV) 3: Three-wire run control 4: Forward jog (FJOG)	1	★
P4-01	Function selection of DI2 terminal	5: Reverse jog (RJOG) 6: Terminals UP 7: Terminals DOWN 8: Free halt 9: Reset bug (RESET) 10: Pause operation	4	★
P4-02	Function selection of DI3 terminal	11: External fault normally open input 12: Multi-stage command terminal 1 13: Multi-stage command terminal 2 14: Multi-stage command terminal 3 15: Multi-stage command terminal 4 16: Acceleration/Deceleration time selection terminal 1 17: Acceleration/Deceleration time selection terminal 2	9	★
P4-03	Function selection of DI4 terminal	18: Frequency source switching 19: UP / DOWN setting cleared (terminal and keyboard) 20: Running command switching terminal 21: Prohibit acceleration/deceleration 22: PID pause 23: PLC state reset 24: Swing frequency pause	12	★
P4-04	Function selection of DI5 terminal	25: Counter input      26: Counter reset 27: Length count input   28: Length reset 29: Torque control disabled 30: PULSE frequency input (valid for DI5) 31: Reserve 32: Prompt DC braking	13	★
P4-05	Function selection of DI6 terminal	33: External fault normally closed input 34: Frequency modification enabled 35: PID action direction negated 36: Exterior halt terminal 1 37: Control command switching terminal 2 38: PID integral pause	0	★
P4-06	Function selection of DI7 terminal	39: Switch of frequency source X and preset frequency 40: Switch of frequency source Y and preset frequency 41: Motor selection terminal 1 42: Motor selection terminal 2	0	★
P4-07	Function selection of DI8 terminal	43: PID parameter switching 44: User-defined fault 1 45: User-defined fault 2 46: Speed control / torque control switch	0	★
P4-08	Function selection of DI9 terminal	47: Emergency halt 48: Exterior halt terminal 2 49: Decelerated DC braking 50: The running time is cleared 51-59: Reserve	0	★
P4-09	Function selection of DI10 terminal			

Code	Name	Setting range	Default	Change
P4-10	DI filtering time	0.000s~1.000s	0.010s	☆
P4-11	Terminal command mode	0: two-wire 1 1: two-wire 2 2: three-wire 1 3: three-wire 2	0	★
P4-12	Terminal UP/DOWN change rate	0.001Hz/s~65.535Hz/s	1.00Hz/s	☆
P4-13	AI curve 1 Min. input	0.00V~P4-15	0.00V	☆
P4-14	Setting of AI curve 1 Min. input	-100.0%~+100.0%	0.0%	☆
P4-15	AI curve 1 Max. input	P4-13~+10.00V	10.00V	☆
P4-16	Setting of AI curve 1 Max. input	-100.0%~+100.0%	100.0%	☆
P4-17	AI1 filtering time	0.00s~10.00s	0.10s	☆
P4-18	AI curve 2 Min. input	0.00V~P4-20	0.00V	☆
P4-19	Setting of AI curve 2 Min. input	-100.0%~+100.0%	0.0%	☆
P4-20	AI curve 2 Max. input	P4-18~+10.00V	10.00V	☆
P4-21	Setting of AI curve 2 Max. input	-100.0%~+100.0%	100.0%	☆
P4-22	AI2 filtering time	0.00s~10.00s	0.10s	☆
P4-23	AI curve 3 Min. input	-10.00V~P4-25	-10.00V	☆
P4-24	Setting of AI curve 3 Min. input	-100.0%~+100.0%	-100.0%	☆
P4-25	AI curve 3 Max. input	P4-23~+10.00V	10.00V	☆
P4-26	Setting of AI curve 3 Max. input	-100.0%~+100.0%	100.0%	☆
P4-27	AI3 filtering time	0.00s~10.00s	0.10s	☆
P4-28	PULSE Min. input	0.00kHz~P4-30	0.00kHz	☆
P4-29	Setting of PULSE Min. input	-100.0%~100.0%	0.0%	☆
P4-30	PULSE Max. input	P4-28~100.00kHz	50.00kHz	☆
P4-31	Setting of PULSE Max. input	-100.0%~100.0%	100.0%	☆
P4-32	PULSE filtering time	0.00s~10.00s	0.10s	☆
P4-33	AI curve selection	Bit: AI1 curve selection 1: Curve 1 (2 point, see P4-13~P4-16) 2: Curve 2 (2 point, see P4-18~P4-21) 3: Curve 3 (2 point, see P4-23~P4-26) 4: Curve 4 (4 point, see A6-00~A6-07) 5: Curve 5 (4 point, see A6-08~A6-15) Ten bit: AI2 curve selection, same as above Hundred bit: AI2 curve selection, same	321	☆
P4-34	AI is below Min. input setting selection	Bit: AI1 is below the minimum input setting 0: correspond to min. input setting 1: 0.0% Ten bit: AI2 is below min. input setting AI3 is below min. input setting	000	☆
P4-35	DI1 delay time	0.0s~3600.0s	0.0s	★
P4-36	DI2 delay time	0.0s~3600.0s	0.0s	★
P4-37	DI3 delay time	0.0s~3600.0s	0.0s	★

Code	Name	Setting range	Default	Change
P4-38	Effective mode selection 1 of DI terminal	0: valid high-level 1: valid low-level Bit: DI1 Ten bit: DI2 Hundred bit: DI3 Thousand bit: DI4 Ten thousand bit: DI5	00000	★
P4-39	Effective mode selection 2 of DI terminal	0: valid high-level 1: valid low-level Bit:DI6 Ten bit: DI7 Hundred bit:DI8 Thousand bit: DI9 Ten thousand bit: DI10	00000	★
Output terminal of P5 group				
P5-00	Output mode selection of FM terminal	0 : Pulse output (FMP) 1 : Switching output (FMR)	0	☆
P5-01	FMR output function selection	0: No output	0	☆
P5-02	Relay function selection of control panel (T/A-T/B-T/C)	1: Operation of frequency converter 2: Fault output (downtime)	2	☆
P5-03	Relay function selection of expansion card (P/A-P/B-P/C)	3: Frequency level detection output FDT1 4: Frequency arrival 5: Zero speed operation (no output halt)	0	☆
P5-04	DO1 output function selection	6: Pre-alarm of motor overload 7: Pre-alarm of converter overload 8: Count value reaches the set 9: Reaching the set count 10: Length arrival 11: PLC cycle is complete 12: Set the accumulated run time 13: Frequency limit 14: Torque limit 15: Ready to run 16: AI1>AI2 17: Upper limit frequency arrival 18: Lower limit frequency reaches (running about) 19: Brown-state output 20: Communication Preferences 21: Positioning complete (reserve) 22: Location close (reserve)	1	☆
P5-05	Output selection of expansion card DO2	23: Zero-speed operation 2 (shutdown also output) 24: Set the accumulated power-on time 25: Frequency level detection output FDT2 26: 1 to the output frequency 27: 2 to the output frequency 28: 1 to the output current 29: 2 to the output current 30: The timing to the output 31: AI1 input overrun 32: Carrying out 33: Reverse operation 34: Zero current state 35: Module temperature reached 36: Output current limit value 37: The lower limit frequency arrival (stop output) 38: Alarm output (continue) 39: Pre-alarm of motor overtemperature 40: The running time arrival	4	☆

Code	Name	Setting range	Default	Change
P5-06	FMP output function selection	0: Operation frequency 1: Setting frequency	0	☆
P5-07	AO1 output function selection	2: Output current 3: Output torque 4: Output power 5: Output voltage 6: PULSE input (100.% corresponds to 100.0kHz) 7: AI1 8: AI2 9: AI3 (expansion card) 10: Length 11: Value 12: Communication setting 13: Motor speed 14: Output current (100.0% is 1000.0A) 15: Output voltage (100.0% is 1000.0V) 16: Reserve	0	☆
P5-08	Output function selection of expansion card AO2		1	☆
P5-09	FMP maximum output frequency	0.01kHz~100.00kHz	50.00kHz	☆
P5-10	AO1 zero offset coefficient	-100.0%~+100.0%	0.0%	☆
P5-11	AO1 gain	-10.00~+10.00	1.00	☆
P5-12	Zero offset coefficient of expansion card AO2	-100.0%~+100.0%	0.0%	☆
P5-13	AO2 gain of expansion card AO2	-10.00~+10.00	1.00	☆
P5-17	FMR output delay time	0.0s~3600.0s	0.0s	☆
P5-18	RELAY1 output delay time	0.0s~3600.0s	0.0s	☆
P5-19	RELAY2 output delay time	0.0s~3600.0s	0.0s	☆
P5-20	DO1 output delay time	0.0s~3600.0s	0.0s	☆
P5-21	DO2 output delay time	0.0s~3600.0s	0.0s	☆
P5-22	Valid state selection of DO output terminal	0: positive logic 1: negative logic Bit: FMR      Ten bit: RELAY1 Hundred bit: RELAY2    Thousand bit: DO1 Ten Thousand bit: DO2	00000	☆
Start/Halt control of P6 group				
P6-00	Start mode	0: Direct start 1: Speed tracking restart 2: Start pre-excitation (AC asynchronous motor)	0	☆
P6-01	Speed tracking mode	0: Start from stop frequency 1: Start from zero speed 2: Start from maximum frequency	0	★
P6-02	Speed tracking speed	1~100	20	☆
P6-03	Start frequency	0.00Hz~10.00Hz	0.00Hz	☆



Code	Name	Setting range	Default	Change
P6-04	Start frequency retention time	0.0s~100.0s	0.0s	★
P6-05	Start DC braking current / Pre-excitation current	0%~100%	0%	★
P6-06	Start DC braking time/ Pre-excitation time	0.0s~100.0s	0.0s	★
P6-07	Acceleration and deceleration mode	0 : Linear acceleration and deceleration 1 : S curve acceleration and deceleration A 2 : S curve acceleration and deceleration B	0	★
P6-08	S curve start section time ratio	0.0%~ (100.0%-P6-09)	30.0%	★
P6-09	S curve ending section time ratio	0.0%~ (100.0%-P6-08)	30.0%	★
P6-10	Halt mode	0: Deceleration to halt, 1: Free halt	0	☆
P6-11	Initial frequency of halt DC braking	0.00Hz~max. frequency	0.00Hz	☆
P6-12	Waiting time of halt DC braking	0.0s~100.0s	0.0s	☆
P6-13	Current of halt DC braking	0%~100%	0%	☆
P6-14	Time of halt DC braking	0.0s~100.0s	0.0s	☆
P6-15	Brake usage	0%~100%	100%	☆
Keyboard and display of P7 group				
P7-01	JOG key function selection	0: Invalid JOG 1 : Switch of operation panel CMD channel and remote CMD channel (terminal CMD channel or CMD channel) 2 : Reversing switch 3 : Forward jog	0	★
P7-02	STOP/RESET key function	0 : Only in keyboard mode, halt function of STOP / RES key is valid 1 : under any operation mode, halt function of STOP/RES is valid	1	☆
P7-03	LED running display parameter 1	0000~FFFF Bit00: running frequency 1 (Hz) Bit01: setting frequency (Hz) Bit02: busbar voltage (V) Bit03: output voltage (V) Bit04: output current (A) Bit05: output power (kW) Bit06: output torque (%) Bit07: DI input state Bit08: DO output state Bit09: AI1 voltage (V) Bit10: AI2 voltage (V) Bit11: AI3 voltage (V) Bit12: Count value Bit13: Length value Bit14: Display loading speed Bit15: PID setting	1F	☆

Code	Name	Setting range	Default	Change
P7-04	LED running display parameter 2	0000~FFFF Bit00: PID Feedback Bit01: PLC stage Bit02: Pulse Input pulse frequency (kHz) Bit03: Operating frequency 2 (Hz) Bit04: Remaining operating time Bit05: AI1 Before the correction voltage (V) Bit06: AI2 before the correction voltage (V) Bit07: AI3 before the correction voltage (V) Bit08: Line speed Bit09: Current power-on time (Hour) Bit10: Current running time (Min) Bit11: PULSE Input pulse frequency (Hz) Bit12: Communication set value Bit13: Encoder feedback speed (Hz) Bit14: Main frequency X display (Hz) Bit15: Frequency Y display (Hz)	0	☆
P7-05	LED halt display parameters	0000~FFFF Bit00: Set frequency (Hz) Bit01: Bus voltage (V) Bit02: DI Input Status Bit03: DO Output status Bit04: AI1 Voltage (V) Bit05: AI2 Voltage (V) Bit06: AI3 Voltage (V) Bit07: The count value Bit08: Length value Bit09: PLC Stage Bit10: Load Speed Bit11: PID Set up Bit12: Pulse Input pulse frequency (kHz)	33	☆
P7-06	Load speed display coefficient	0.0001~6.5000	1.0000	☆
P7-07	Radiator temperature of inverter	0.0℃~100.0℃	-	●
P7-08	Radiator temperature of rectifier	0.0℃~100.0℃	-	●
P7-09	Total running time	0h~65535h	-	●
P7-10	Product No.	-	-	●
P7-11	Software version number	-	-	●
P7-12	Load speed display decimal digits	0: 0 decimal places 1: 1 decimal places 2: 2 decimal places 3: 3 decimal places	1	☆
P7-13	Cumulative power-up time	0h~65535h	-	●
P7-14	Total power consumption	0~65535KWh	-	●
Auxiliary function of P8 group				
P8-00	Jog frequency	0.00Hz~max. frequency	2.00Hz	☆
P8-01	Jog acceleration time	0.0s~6500.0s	20.0s	☆
P8-02	Jog deceleration time	0.0s~6500.0s	20.0s	☆

Code	Name	Setting range	Default	Change
P8-03	Acceleration time 2	0.0s~6500.0s	machine type	☆
P8-04	Deceleration time 2	0.0s~6500.0s	machine type	☆
P8-05	Acceleration time 3	0.0s~6500.0s	machine type	☆
P8-06	Deceleration time 3	0.0s~6500.0s	machine type	☆
P8-07	Acceleration time 4	0.0s~6500.0s	machine type	☆
P8-08	Deceleration time 4	0.0s~6500.0s	machine type	☆
P8-09	Hopping frequency 1	0.00Hz~max. frequency	0.00Hz	☆
P8-10	Hopping frequency 2	0.00Hz~max. frequency	0.00Hz	☆
P8-11	Hopping frequency range	0.00Hz~max. frequency	0.01Hz	☆
P8-12	Reversible dead time	0.0s~3000.0s	0.0s	☆
P8-13	Inversion of control enables	0: allow 1: prohibit	0	☆
P8-14	Operation mode of set frequency being lower than lower limit frequenc	0: operate at lower limit frequency 1: halt 2: zero-speed operation	0	☆
P8-15	Droop control	0.00Hz~10.00Hz	0.00Hz	☆
P8-16	Set accumulated power-on time	0h~65000h	0h	☆
P8-17	Set accumulated run time	0h~65000h	0h	☆
P8-18	Start protection selection	0: no protection 1: protection	0	☆
P8-19	Frequency detection value	0.00Hz~max. frequency	50.00Hz	☆
P8-20	Frequency detection hysteresis value	0.0%~100.0% (FDT1 level)	5.0%	☆
P8-21	Frequency arrival detection width	0.0%~100.0% (max. frequency)	0.0%	☆
P8-22	If jopping frequency is valid in acceleration/deceleration	0: invalid 1: valid	0	☆
P8-25	Switch frequency between acceleration time 1 and 2	0.00Hz~max. frequency	0.00Hz	☆
P8-26	Switch frequency between deceleration time 1 and 2	0.00Hz~max. frequency	0.00Hz	☆
P8-27	Terminal jog priority	0: invalid 1: valid	0	☆
P8-28	Frequency detection value	0.00Hz~max. frequency	50.00Hz	☆
P8-29	Frequency detection hysteresis value	0.0%~100.0% (FDT2 level)	5.0%	☆
P8-30	Any frequency detection value 1	0.00Hz~max. frequency	50.00Hz	☆
P8-31	Any frequency detection width 1	0.0%~100.0% (max. frequency)	0.0%	☆
P8-32	Any frequency detection value 2	0.00Hz~max. frequency	50.00Hz	☆
P8-33	Any frequency detection width 2	0.0%~100.0% (max. frequency)	0.0%	☆
P8-34	Zero-current detection level	0.0%~300.0% 100.0% is rated current	5.0%	☆
P8-35	Zero-current detection delay time	0.01s~600.00s	0.10s	☆
P8-36	Output current limit value	0.0% (no detection) 0.1%~300.0% (rated current of motor)	200.0%	☆

Code	Name	Setting range	Default	Change
P8-37	Output current limit detects delay time	0.00s~600.00s	0.00s	☆
P8-38	Any arrival current 1	0.0%~300.0% (rated current of motor)	100.0%	☆
P8-39	Width of any arrival current 1	0.0%~300.0% (rated current of motor)	0.0%	☆
P8-40	Any arrival current 2	0.0%~300.0% (rated current of motor)	100.0%	☆
P8-41	Width of any arrival current 2	0.0%~300.0% (rated current of motor)	0.0%	☆
P8-42	Timing function selection	0: invalid 1: valid	0	☆
P8-43	Timing operation time selection	0: P8-44 setting; 1: AI1; 2: AI2; 3: AI3 Anolog input range corresponds to P8-44	0	☆
P8-44	Timing operation time	0.0Min~6500.0Min	0.0Min	☆
P8-45	Lower limit of AI1 input voltage protection value	0.00V~P8-46	3.10V	☆
P8-46	Upper limit of AI1 input voltage protection value	P8-45~10.00V	6.80V	☆
P8-47	Module temperature reached	0℃~100℃	75℃	☆
P8-48	Cooling fan control	0: The fan operates when running 1: The fan has been running	0	☆
P8-49	Wake frequency	Sleep frequency (P8-51)~maximum frequency (P0-10)	0.00Hz	☆
P8-50	Wake-up delay time	0.0s~6500.0s	0.0s	☆
P8-51	Sleep frequency	0.00Hz~wake frequency (P8-49)	0.00Hz	☆
P8-52	Sleep latency	0.0s~6500.0s	0.0s	☆
P8-53	Arrival time setting of operation	0.0Min~6500.0Min	0.0Min	☆
Fault and protection of P9 group				
P9-00	Motor overload protection	0: allow 1: prohibit	1	☆
P9-01	Motor overload protection gain	0.20~10.00	1.00	☆
P9-02	Motor overload warning coefficient	50%~100%	80%	☆
P9-03	Overvoltage stall gain	0~100	0	☆
P9-04	Overvoltage stall protection voltage	120%~150%	130%	☆
P9-05	Over current stall gain	0~100	20	☆
P9-06	Over current stall protection current	100%~200%	150%	☆
P9-07	To-ground short circuit protection	0: invalid 1: valid	1	☆
P9-09	Auto reset times of fault	0~20	0	☆
P9-10	DO action during auto reset of fault	0: no action 1: action	0	☆
P9-11	Automatic reset interval of fault	0.1s~100.0s	1.0s	☆
P9-12	Input phase loss protection	0: allow 1: prohibit	1	☆
P9-13	Output phase loss protection	0: allow 1: prohibit	1	☆

Code	Name	Setting range	Default	Change
p9-14	Type of first fault	0: No fault 1: Reserve 2: Acceleration overcurrent 3: Deceleration overcurrent 4: Over current constant 5: Overvoltage acceleration 6: Deceleration overvoltage 7: Constant speed overvoltage 8: Buffer overload resistance 9: Brown 10: Converter overload 11: Motor overload 12: Input phase	—	●
p9-15	Type of second fault	13: Output phase 14: Module overheating 15: External fault 16: Abnormal communication 17: Abnormal contact 18: Current detecting abnormal 19: Abnormal motor tuning 20: Abnormal encoder / PG card 21: Abnormal reading/writing parameters 22: Hardware exception of converter 23: Hardware exception of converter 24: Reserve 25: Reserve	—	●
p9-16	Type of second (recent) fault	26: Running time arrival 27: User-defined fault 1 28: User-defined fault 2 29: Power-on time is reached 30: Carrying out 31: Runtime PID feedback loss 40: Fast current-limit timeout 41: When switching the motor running 42: Excessive speed deviation 43: Motor overspeed 45: Motor overtemperature 51: The initial position error	—	●
p9-17	Frequency of second (recent) fault	—	—	●
p9-18	Current of second (recent) fault	—	—	●
p9-19	Busbar voltage of second (recent) fault	—	—	●
p9-20	Input terminal status of second (recent) fault	—	—	●
p9-21	Output terminal status of second (recent) fault	—	—	●
p9-22	Converter status of second (recent) fault	—	—	●
p9-23	Electrifying time of second (recent) fault	—	—	●

Code	Name	Setting range	Default	Change
p9-24	Running time of second (recent) fault	—	—	●
p9-27	Frequency of second fault	—	—	●
p9-28	Current of second fault	—	—	●
p9-29	Busbar voltage of second fault	—	—	●
p9-30	Input terminal status of second fault	—	—	●
p9-31	Output terminal status of second fault	—	—	●
p9-32	Convertor status of second fault	—	—	●
p9-33	Electrifying time of second fault	—	—	●
p9-34	Running time of second fault	—	—	●
p9-37	Frequency of first fault	—	—	●
p9-38	Current of first fault	—	—	●
p9-39	Busbar voltage of first fault	—	—	●
p9-40	Input terminal status of first fault	—	—	●
p9-41	Output terminal status of first fault	—	—	●
p9-42	Convertor status of first fault	—	—	●
p9-43	Electrifying time of first fault	—	—	●
p9-44	Running time of first fault	—	—	●
p9-47	Fault protection action selection 1	Bit: Motor overload (11) 0: Free halt 1: Stop according to stop mode 2: Continue to run Ten bit: Input phase (12) Hundred bit: Output phase (13) Thousand bit: External fault (15) Ten thousand bit: Abnormal communication (16)	00000	☆
p9-48	Fault protection action selection 2	Bit: Abnormal encoder / PG card (20) 0: Free halt Ten bit: Abnormal function code reader (21) 0: Free halt 1: Stop according to stop mode Hundred bit: Reserve Thousand bit: Motor overheating (25) Ten thousand bit: Running time arrival (26)	00000	☆

Code	Name	Setting range	Default	Change
p9-49	Fault protection action selection 3	Bit: User-defined fault 1 (27) 0: Free halt 1: Stop according to stop mode 2: Continue to run Hundred bit: Power-on time is reached (29) Thousand bit: Carrying out (30) 0: Free halt 1: Deceleration to stop 2: Decelerated to 7% of the rated motor frequency continues to run, When you can not afford to load automatically restored to the set frequency operation Ten thousand bit: Runtime PID feedback loss (31) 0: Free halt 1: Stop according to stop mode 2: Continue to run	00000	☆
p9-50	Fault protection action selection 4	Bit: Excessive speed deviation (42) 0: Free halt 1: Stop according to stop mode 2: Continue to run Ten bit: Super speed motor (43) Hundred bit: The initial position error (51)	00000	☆
p9-54	Continue to run frequency selection when fault happens	0: In the current operating frequency operation 1: Run at set frequency 2: Run at upper limit frequency 3: Lower limit frequency operation 4: Alternate abnormal frequency operation	0	☆
p9-55	Abnormal alternative frequency	60.0%~100.0% (100.0% Corresponding to the maximum frequencyP0-10)	100.0%	☆
p9-56	Motor temperature sensor type	0: no temperature sensor 1: PT100 2: PT1000	0	☆
p9-57	Motor overheating protection threshold	0℃~200℃	110℃	☆
p9-58	Motor overheating prediction alert threshold	0℃~200℃	90℃	☆
p9-59	Instantaneous power failure action selection	0: invalid 1: deceleration 2: deceleration to halt	0	☆
p9-60	Retention	P9-62~100.0%	100.0%	☆
p9-61	Instantaneous power voltage recovery judgment time	0.00s~100.00s	0.50s	☆
p9-62	Instant power cut action judging voltage	60.0%~100.0% (standard busbar voltage)	80.0%	☆
p9-63	Load missing protection selection	0: invalid 1: valid	0	☆
p9-64	Load missing detection level	0.0~100.0%	10.0%	☆

Code	Name	Setting range	Default	Change
P9-65	Load missing testing time	0.0~60.0s	1.0s	☆
P9-67	Over-speed detection value	0.0%~50.0% (max. frequency)	20.0%	☆
P9-68	Over-speed detection time	0.0s~60.0s	5.0s	☆
P9-69	Excessive speed deviation detection value	0.0%~50.0%(max. frequency)	20.0%	☆
P9-70	Excessive speed deviation detection time	0.0s~60.0s	0.0s	☆
PID function of FA group				
PA-00	PID given source	0: PA-01 set up 1: AI1; 2: AI2; 3: AI3 4: Pulse setting (DI5) 5: Communication given 6: Multi-section instruction given	0	☆
PA-01	PID values given	0.0%~100.0%	50.0%	☆
PA-02	PID feedback source	0: AI1; 1: AI2; 2: AI3; 3: AI1-AI2 4: PULSE setting (DI5) 5: Communication given 6: AI1+AI2 7: MAX ( AI1 ,  AI2 ) 8: MIN ( AI1 ,  AI2 )	0	☆
PA-03	PID action direction	0: positive action 1: negative action	0	☆
PA-04	PID given feedback range	0~65535	1000	☆
PA-05	Proportional gain Kp1	0.0~100.0	20.0	☆
PA-06	Integration time Ti1	0.01s~10.00s	2.00s	☆
PA-07	Differential time Td1	0.000s~10.000s	0.000s	☆
PA-08	PID reverse cut-off frequency	0.00~max. frequency	2.00Hz	☆
PA-09	PID deviation limit	0.0%~100.0%	0.0%	☆
PA-10	PID differential limiting	0.00%~100.00%	0.10%	☆
PA-11	PID given change time	0.00~650.00s	0.00s	☆
PA-12	PID feedback filter time	0.00~60.00s	0.00s	☆
PA-13	PID output filter time	0.00~60.00s	0.00s	☆
PA-14	Retention	-	-	☆
PA-15	Proportional gain Kp2	0.0~100.0	20.0	☆
PA-16	Integration time Ti2	0.01s~10.00s	2.00s	☆
PA-17	Differential time Td2	0.000s~10.000s	0.000s	☆
PA-18	PID parameters switching condition	0: Not switch 1: By DI terminal switch 2: Automatic switching based on bias	0	☆



Code	Name	Setting range	Default	Change
PA-19	PID parameter switching deviation 1	0.0%~PA-20	20.0%	☆
PA-20	PID parameter switching deviation 2	PA-19~100.0%	80.0%	☆
PA-21	Initial PID	0.0%~100.0%	0.0%	☆
PA-22	Hold time of initial PID	0.00~650.00s	0.00s	☆
PA-23	Forward max. of two output bias	0.00%~100.00%	1.00%	☆
PA-24	Reverse max. of two output bias	0.00%~100.00%	1.00%	☆
PA-25	PID integral property	Bit: Integral separation 0: Invalid; 1: Valid Ten bit: Integral to whether to stop the output limit 0: Continued integration 1: Stop Points	00	☆
PA-26	PID feedback loss detection value	0.0%: do not judge feedback loss 0.1%~100.0%	0.0%	☆
PA-27	PID feedback loss detection time	0.0s~20.0s	0.0s	☆
PA-28	PID stoppage operation	0: Stop operation; 1: Shutdown operation	0	☆
Swing frequency, length and count of Pb group				
Pb-00	Setting way of swing frequency	0: Relative to central frequency 1: relative to the maximum frequency	0	☆
Pb-01	Swing frequency range	0.0%~100.0%	0.0%	☆
Pb-02	Kick frequency range	0.0%~50.0%	0.0%	☆
Pb-03	Kick frequency cycle	0.1s~3000.0s	10.0s	☆
Pb-04	Triangular wave rising time	0.1%~100.0%	50.0%	☆
Pb-05	Set length	0m~65535m	1000m	☆
Pb-06	Actual length	0m~65535m	0m	☆
Pb-07	Number of pulses per meter	0.1~6553.5	100.0	☆
Pb-08	Set count value	1~65535	1000	☆
Pb-09	Designated count value	1~65535	1000	☆
Multi-stage command and simple PLC in PC group				
PC-00	Multi-stage command 0	-100.0%~100.0%	0.0%	☆
PC-01	Multi-stage command 1	-100.0%~100.0%	0.0%	☆
PC-02	Multi-stage command 2	-100.0%~100.0%	0.0%	☆
PC-03	Multi-stage command 3	-100.0%~100.0%	0.0%	☆
PC-04	Multi-stage command 4	-100.0%~100.0%	0.0%	☆
PC-05	Multi-stage command 5	-100.0%~100.0%	0.0%	☆
PC-06	Multi-stage command 6	-100.0%~100.0%	0.0%	☆
PC-07	Multi-stage command 7	-100.0%~100.0%	0.0%	☆
PC-08	Multi-stage command 8	-100.0%~100.0%	0.0%	☆

Code	Name	Setting range	Default	Change
PC-09	Multi-stage command 9	-100.0%~100.0%	0.0%	☆
PC-10	Multi-stage command 10	-100.0%~100.0%	0.0%	☆
PC-11	Multi-stage command 11	-100.0%~100.0%	0.0%	☆
PC-12	Multi-stage command 12	-100.0%~100.0%	0.0%	☆
PC-13	Multi-stage command 13	-100.0%~100.0%	0.0%	☆
PC-14	Multi-stage command 14	-100.0%~100.0%	0.0%	☆
PC-15	Multi-stage command 15	-100.0%~100.0%	0.0%	☆
PC-16	Simple PLC operation mode	0: Stop at the end of single running 1: End of single running holding final value 2: Been circulating	0	☆
PC-17	Memory selection after power failure of simple PLC	Bit: memory selection after power failure 0: no memory after power failure 1: memory after power failure Ten bit: memory selection after halt 0: no memory after halt 1: memory after halt	00	☆
PC-18	Simple PLC running time of seg. 0	0.0s (h) ~6553.5s (h)	0.0s (h)	☆
PC-19	Simple PLC acceleration/ deceleration time of segment 0	0~3	0	☆
PC-20	Simple PLC running time of seg. 1	0.0s (h)~6553.5s (h)	0.0s (h)	☆
PC-21	Simple PLC acceleration/ deceleration time of segment 1	0~3	0	☆
PC-22	Simple PLC running time of seg. 2	0.0s (h)~6553.5s (h)	0.0s (h)	☆
PC-23	Simple PLC acceleration/ deceleration time of segment 2	0~3	0	☆
PC-24	Simple PLC running time of seg. 3	0.0s (h)~6553.5s (h)	0.0s (h)	☆
PC-25	Simple PLC acceleration/ deceleration time of segment 3	0~3	0	☆
PC-26	Simple PLC running time of seg. 4	0.0s (h)~6553.5s (h)	0.0s (h)	☆
PC-27	Simple PLC acceleration/ deceleration time of segment 4	0~3	0	☆
PC-28	Simple PLC running time of seg. 5	0.0s (h)~6553.5s (h)	0.0s (h)	☆
PC-29	Simple PLC acceleration/ deceleration time of segment 5	0~3	0	☆
PC-30	Simple PLC running time of seg. 6	0.0s (h)~6553.5s (h)	0.0s (h)	☆
PC-31	Simple PLC acceleration/ deceleration time of segment 6	0~3	0	☆
PC-32	Simple PLC running time of seg. 7	0.0s (h)~6553.5s (h)	0.0s (h)	☆
PC-33	Simple PLC acceleration/ deceleration time of segment 7	0~3	0	☆
PC-34	Simple PLC running time of seg. 8	0.0s (h)~6553.5s (h)	0.0s (h)	☆
PC-35	Simple PLC acceleration/ deceleration time of segment 8	0~3	0	☆

Code	Name	Setting range	Default	Change
PC-36	Simple PLC running time of seg. 9	0.0s (h)~6553.5s (h)	0.0s (h)	☆
PC-37	Simple PLC acceleration/ deceleration time of segment 9	0~3	0	☆
PC-38	Simple PLC running time of seg. 10	0.0s (h)~6553.5s (h)	0.0s (h)	☆
PC-39	Simple PLC acceleration/ deceleration time of segment 10	0~3	0	☆
PC-40	Simple PLC running time of seg. 11	0.0s (h)~6553.5s (h)	0.0s (h)	☆
PC-41	Simple PLC acceleration/ deceleration time of segment 11	0~3	0	☆
PC-42	Simple PLC running time of seg. 12	0.0s (h)~6553.5s (h)	0.0s (h)	☆
PC-43	Simple PLC acceleration/ deceleration time of segment 12	0~3	0	☆
PC-44	Simple PLC running time of seg. 13	0.0s (h)~6553.5s (h)	0.0s (h)	☆
PC-45	Simple PLC acceleration/ deceleration time of segment 13	0~3	0	☆
PC-46	Simple PLC running time of seg. 14	0.0s (h)~6553.5s (h)	0.0s (h)	☆
PC-47	Simple PLC acceleration/ deceleration time of segment 14	0~3	0	☆
PC-48	Simple PLC running time of seg. 15	0.0s (h)~6553.5s (h)	0.0s (h)	☆
PC-49	Simple PLC acceleration/ deceleration time of segment 15	0~3	0	☆
PC-50	Simple PLC running time unit	0: s (second) 1: h (hour)	0	☆
PC-51	Given way of multi-stage command 0	0: PC-00 function code given 1: AI1 2: AI2 3: AI3 4: PULSE 5: PID 6: Preset frequency (P0-08) given, UP / DOWN Can be modified	0	☆
Communication parameter of Pd group				

Code	Name	Setting range	Default	Change
Pd-00	Baud rate	Bit: MODBUS 0: 300BPS 1: 600BPS 2: 1200BPS 3: 2400BPS 4: 4800BPS 5: 9600BPS 6: 19200BPS 7: 38400BPS 8: 57600BPS 9: 115200BPS Ten bit: reserve Hundred bit: reserve Thousand bit: CANlink Baud rate 0: 20 1: 50 2: 100 3: 125 4: 250 5: 500 6: 1M	6005	☆
Pd-01	Data format	0: No inspection (8-N-2) 1: Enven parity check (8-E-1) 2: Even parity (8-O-1) 3: 8-N-1	0	☆
Pd-02	Native address	1~247, 0 is broadcast address	1	☆
Pd-03	Response delay	0ms~20ms	2	☆
Pd-04	Communication overtime	0.0 (invalid), 0.1s~60.0s	0.0	☆
Pd-05	Data transfer format selection	Single digit: MODBUS 0: Non-standard MODBUS protocol 1: Standard MODBUS protocol Ten bit: Reserved	30	☆
Pd-06	Communication reads current resolution	0: 0.01A 1: 0.1A	0	☆
User-defined function code of PE group				

Code	Name	Setting range	Default	Change
PE-00	User function code 0	P0-00 ~ PP-xx A0-00 ~ Ax-xx U0-xx ~ U0-xx	P0.10	☆
PE-01	User function code 1		P0.02	☆
PE-02	User function code 2		P0.03	☆
PE-03	User function code 3		P0.07	☆
PE-04	User function code 4		P0.08	☆
PE-05	User function code 5		P0.17	☆
PE-06	User function code 6		P0.18	☆
PE-07	User function code 7		P3.00	☆
PE-08	User function code 8		P3.01	☆
PE-09	User function code 9		P4.00	☆
PE-10	User function code 10		P4.01	☆
PE-11	User function code 11		P4.02	☆
PE-12	User function code 12		P5.04	☆
PE-13	User function code 13		P5.07	☆
PE-14	User function code 14		P6.00	☆
PE-15	User function code 15		P6.10	☆
PE-16	User function code 16		P0.00	☆
PE-17	User function code 17		P0.00	☆
PE-18	User function code 18		P0.00	☆
PE-19	User function code 19		P0.00	☆
PE-20	User function code 20		P0.00	☆
PE-21	User function code 21		P0.00	☆
PE-22	User function code 22		P0.00	☆
PE-23	User function code 23		P0.00	☆
PE-24	User function code 24		P0.00	☆
PE-25	User function code 25		P0.00	☆
PE-26	User function code 26		P0.00	☆
PE-27	User function code 27		P0.00	☆
PE-28	User function code 28		P0.00	☆
PE-29	User function code 29	P0.00	☆	
Function code management of PP group				
PP-00	User password	0~65535	0	☆
pp-01	Parameter initialization	0: No operation 01: Restore factory settings, not including the motor parameters 02: Clear History Information 04: Current backup user parameters 501: Recover user backup parameters	0	★

Code	Name	Setting range	Default	Change
PP-02	Function parameter display selection	Bit: U group display selection 0: not display 1: display Ten bit: A group display selection 0: not display 1: display	11	★
PP-03	Individualized parameter group display selection	Bit: user-defined parameter group display selection 0: not display 1: display Bit: user-modified parameter group display selection 0: not display 1: display	00	☆
PP-04	Modifying property of function code	0: be modified 1: not modified	0	☆
Torque control parameters of A0 group				
A0-00	Speed/torque control way	0: speed control 1: torque control	0	★
A0-01	Setting source of torque under torque control mode	0: Digital setting 1 (A0-03) 1: AI1 2: AI2 3: AI3 4: PULSE 5: Communication given 6: MIN (AI1, AI2) 7: MAX (AI1, AI2) (1-7 full-scale option, the corresponding digital setting A0-03)	0	★
A0-03	Digital setting of torque under torque control mode	-200.0%~200.0%	150.0%	☆
A0-05	Positive max. frequency of torque control	0.00Hz~max. frequency	50.00Hz	☆
A0-06	Negative max. frequency of torque control	0.00Hz~max. frequency	50.00Hz	☆
A0-07	Acceleration time of torque control	0.00s~65000s	0.00s	☆
A0-08	Deceleration time of torque control	0.00s~65000s	0.00s	☆
A1 group				
Control of second motor of A2 group				
A2-00	Type selection of motor	0: Common induction motor 1: Variable frequency induction motors	0	★
A2-01	Rated power of motor	0.1kW~1000.0kW	machine type	★
A2-02	Rated voltage of motor	1V~400V	machine type	★
A2-03	Rated current of motor	0.01A~655.35A (converter power ≤55kW) 0.1A~6553.5A (converter power >55kW)	machine type	★
A2-04	Rated frequency of motor	0.01Hz~max. frequency	machine type	★
A2-05	Rated speed of motor	1rpm~65535rpm	machine type	★

Code	Name	Setting range	Default	Change
A2-06	Stator resistance of asynchronous motor	0.001Ω~65.535Ω (converter power ≤55kW) 0.0001Ω~6.5535Ω (converter power >55kW)	machine type	★
A2-07	Rotor resistance of asynchronous motor	0.001Ω~65.535Ω (converter power ≤55kW) 0.0001Ω~6.5535Ω (converter power >55kW)	machine type	★
A2-08	Leakage inductive reactance of asynchronous motor	0.01mH~655.35mH (converter power ≤55kW) 0.001mH~65.535mH (converter power >55kW)	machine type	★
A2-09	Mutual inductive reactance of asynchronous motor	0.1mH~6553.5mH (converter power ≤55kW) 0.01mH~655.35mH (converter power >55kW)	machine type	★
A2-10	No-load current of asynchronous motor	0.01A~A2-03(converter power ≤55kW) 0.1A~A2-03 (converter power >55kW)	machine type	★
A2-27	Encoder line number	1~65535	1024	★
A2-28	Encoder type	0: ABZ incremental encoder 1: Reserved 2: Resolver	0	★
A2-29	Speed feedback PG selection	0: Local PG 1: Local PG 2: Pulse input (DI5)	0	★
A2-30	ABZ incremental encoder AB phase sequence	0: Forward 1: Reverse	0	★
A2-34	Pole-pairs number of rotary transformer	1~65535	1	★
A2-36	Speed feedback PG disconnection detection time	0.0: no action 0.1s~10.0s	0.0	★
A2-37	Tuning selection	0: No operation 1: asynchronous machine static tuning 2: asynchronous machine complete tuning	0	★
A2-38	Speed loop proportional gain 1	1~100	30	☆
A2-39	Speed loop integral time 1	0.01s~10.00s	0.50s	☆
A2-40	Switching frequency 1	0.00~A2-43	5.00Hz	☆
A2-41	Speed loop proportional gain 2	1~100	20	☆
A2-42	Speed loop integral time 2	0.01s~10.00s	1.00s	☆
A2-43	Switching frequency 2	A2-40~max. frequency	10.00Hz	☆
A2-44	Vector control slip gain	50%~200%	100%	☆
A2-45	Speed loop filter time constant	0.000s~0.100s	0.000s	☆
A2-46	Vector control over excitation gain	0~200	64	☆

Code	Name	Setting range	Default	Change
A2-47	Upper limit source under speed control mode	0: A2-48Set up 1: AI1 2: AI2 3: AI3 4: PULSE 5: Communication given 6: MIN (AI1, AI2) 7: MAX (AI1, AI2) 1-7 Full-scale option, the corresponding digital setting A2-48	0	☆
A2-48	Digital setting of torque under speed control mode	0.0%~200.0%	150.0%	☆
A2-51	Excitation proportional gain	0~20000	2000	☆
A2-52	Excitation integral gain	0~20000	1300	☆
A2-53	Torque proportional gain	0~20000	2000	☆
A2-54	Torque integral gain	0~20000	1300	☆
A2-55	Integral property of speed ring	Single digit: Integral separation 0: Invalid 1: Valid	0	☆
A2-61	Control way of 2 <sup>nd</sup> motor	0: No speed Sensor vector control (SVC) 1: speed sensor vector control (FVC) 2: V / F control	0	★
A2-62	Acceleration/Deceleration time of 2 <sup>nd</sup> motor	0: The same as the first motor 1: Acceleration and deceleration time 1 2: Acceleration and deceleration time 2 3: Acceleration and deceleration time 3 4: Acceleration and deceleration time 4	0	☆
A2-63	Torque boost of 2 <sup>nd</sup> motor	0.0%: Automatic torque boost 0.1%~30.0%	machine type	☆
A2-65	Oscillation suppression gain of 2 <sup>nd</sup> motor	0~100	machine type	☆
Control optimization parameters of A5 group				
A5-00	DPWM switches upper limit of frequency	0.00Hz~15.00Hz	12.00Hz	☆
A5-01	PWM modulation mode	0: Asynchronous modulation 1: Synchronous modulationv	0	☆
A5-02	Dead-time compensation mode	0: Without compensation 1: compensation mode 1 2: compensation mode 2	1	☆
A5-03	Random PWM depth	0: Random PWM invalid 1~10:PWM carrier frequency random depth	0	☆
A5-04	Enable fast current-limiting	0: Not enabled 1: Enable	1	☆
A5-05	Current detection compensation	0~100	5	☆
A5-06	Brown-point setting	60.0%~140.0%	100.0%	☆



A5-07	SVC optimization model	0: not optimize 1: optimization model 1 2: optimization model 2	1	☆
A5-08	Dead-time adjustment	100%~200%	150%	☆
Code	Name	Setting range	Default	Change
AI curve setting of A6 group				
A6-00	Min. input of AI curve 4	-10.00V~A6-02	0.00V	☆
A6-01	Setting for min. input of AI curve 4	-100.0%~+100.0%	0.0%	☆
A6-02	Input of inflection point 1 of AI curve 4	A6-00~A6-04	3.00V	☆
A6-03	Setting for input of inflection point 1 of AI curve 4	-100.0%~+100.0%	30.0%	☆
A6-04	Input of inflection point 2 of AI curve 4	A6-02~A6-06	6.00V	☆
A6-05	Setting for input of inflection point 2 of AI curve 4	-100.0%~+100.0%	60.0%	☆
A6-06	Max. input of AI curve 4	A6-06~+10.00V	10.00V	☆
A6-07	Setting for max. input of AI curve 4	-100.0%~+100.0%	100.0%	☆
A6-08	Min. input of AI curve 5	-10.00V~A6-10	-10.00V	☆
A6-09	Setting for min. input of AI curve 5	-100.0%~+100.0%	-100.0%	☆
A6-10	Input of inflection point 1 of AI curve 5	A6-08~A6-12	-3.00V	☆
A6-11	Setting for input of inflection point 1 of AI curve 5	-100.0%~+100.0%	-30.0%	☆
A6-12	Input of inflection point 2 of AI curve 5	A6-10~A6-14	3.00V	☆
A6-13	Setting for input of inflection point 2 of AI curve 5	-100.0%~+100.0%	30.0%	☆
A6-14	Max. input of AI curve 5	A6-12~+10.00V	10.00V	☆
A6-15	Setting for max. input of AI curve 5	-100.0%~+100.0%	100.0%	☆
A6-24	AI1 sets jump point	-100.0%~100.0%	0.0%	☆
A6-25	AI1 sets jump range	0.0%~100.0%	0.5%	☆
A6-26	AI2 sets jump point	-100.0%~100.0%	0.0%	☆
A6-27	AI2 sets jump range	0.0%~100.0%	0.5%	☆
A6-28	AI3 sets jump point	-100.0%~100.0%	0.0%	☆
A6-29	AI3 sets jump range	0.0%~100.0%	0.5%	☆

Code	Name	Setting range	Default	Change
A7-05	On-off output	Binary setting Bit: FMR Ten bit: relay 1 Hundred bit: DO	1	☆
A7-06	Frequency given of programmable card	0.00%~100.00%	0.0%	☆
A7-07	Torque given of programmable card	-200.0%~200.0%	0.0%	☆
A7-08	Command given of programmable card	0: no command 1: forward command 2: reverse command 3: forward inching 4: reverse inching 5: free halt 6: deceleration halt 7: fault reset	0	☆
A7-09	Fault given of programmable card	0: no fault 80~89: fault code	0	☆
AIAO calibration of AC group				
AC-00	AI1 measured voltage 1	0.500V~4.000V	Calibration	☆
AC-01	AI1 display voltage 1	0.500V~4.000V	Calibration	☆
AC-02	AI1 measured voltage 2	6.000V~9.999V	Calibration	☆
AC-03	AI1 display voltage 2	6.000V~9.999V	Calibration	☆
AC-04	AI2 measured voltage 1	0.500V~4.000V	Calibration	☆
AC-05	AI2 display voltage 1	0.500V~4.000V	Calibration	☆
AC-06	AI2 measured voltage 2	6.000V~9.999V	Calibration	☆
AC-07	AI2 display voltage 2	6.000V~9.999V	Calibration	☆
AC-08	AI3 measured voltage 1	-9.999V~10.000V	Calibration	☆
AC-09	AI3 display voltage 1	-9.999V~10.000V	Calibration	☆
AC-10	AI3 measured voltage 2	-9.999V~10.000V	Calibration	☆
AC-11	AI3 display voltage 2	-9.999V~10.000V	Calibration	☆
AC-12	AO1 target voltage 1	0.500V~4.000V	Calibration	☆
AC-13	AO1 measured voltage 1	0.500V~4.000V	Calibration	☆
AC-14	AO1 target voltage 2	6.000V~9.999V	Calibration	☆
AC-15	AO1 measured voltage 2	6.000V~9.999V	Calibration	☆
AC-16	AO2 target voltage 1	0.500V~4.000V	Calibration	☆
AC-17	AO2 measured voltage 1	0.500V~4.000V	Calibration	☆
AC-18	AO2 target voltage 2	6.000V~9.999V	Calibration	☆
AC-19	AO2 measured voltage 2	6.000V~9.999V	Calibration	☆
AC-20	AI2 measured current 1	0.000mA~20.000mA	Calibration	☆
AC-21	AI2 sampling current 1	0.000mA~20.000mA	Calibration	☆

Code	Name	Setting range	Default	Change
AC-22	AI2 measured current 2	0.000mA~20.000mA	Calibration	☆
AC-23	AI2 sampling current 2	0.000mA~20.000mA	Calibration	☆
AC-24	AO1 ideal current 1	0.000mA~20.000mA	Calibration	☆
AC-25	AO1 measured current 1	0.000mA~20.000mA	Calibration	☆
AC-24	AO1 ideal current 2	0.000mA~20.000mA	Calibration	☆
AC-25	AO1 measured current 2	0.000mA~20.000mA	Calibration	☆

Table of monitoring parameters

Function code	Name	Min. unit
Basic monitoring parameters of U0 group		
U0-00	Running frequency (Hz)	0.01Hz
U0-01	Setting frequency (Hz)	0.01Hz
U0-02	Busbar voltage (V)	0.1V
U0-03	Output voltage (V)	1V
U0-04	Output current (A)	0.01A
U0-05	Output power (kW)	0.1kW
U0-06	Output torque (%)	0.1%
U0-07	DI input state	1
U0-08	DO output state	1
U0-09	AI1 voltage (V)	0.01V
U0-10	AI2 voltage (V)	0.01V
U0-11	AI3 voltage (V)	0.01V
U0-12	Count value	1
U0-13	Length value	1
U0-14	Loading speed display	1
U0-15	PID setting	1
U0-16	PID feedback	1
U0-17	PLC stage	1
U0-18	Input PULSE frequency (Hz)	0.01kHz
U0-19	Feedback speed (0.1Hz)	0.1Hz
U0-20	Surplus operation run	0.1Min
U0-21	AI1 voltage before calibration	0.001V
U0-22	AI2 voltage before calibration	0.001V
U0-23	AI3 voltage before calibration	0.001V

U0-24	Linear speed	1m/Min
U0-25	Current electrifying time	1Min
U0-26	Current running time	0.1Min
U0-27	Input PULSE frequency	1Hz
U0-28	Communication given value	0.01%
U0-29	Feedback speed of encoder	0.01Hz
U0-30	Display of main frequency X	0.01Hz
U0-31	Display of auxiliary frequency Y	0.01Hz
U0-32	View any memory address value	1
U0-34	Motor temperature	1℃
U0-35	Target torque (%)	0.1%
U0-36	Rotating location	1
U0-37	Angle of power factor	0.1°
U0-39	Vf separates target voltage	1V
U0-40	Vf separates output voltage	1V
U0-41	Visual display of DI input state	1
U0-42	Visual display of DO input state	1
U0-43	Visual display 1 of DI function state (function 01-function 40)	1
U0-44	Visual display 2 of DI function state (function 41-function 80)	1
U0-59	Setting frequency (%)	0.01%
U0-60	Running frequency (%)	0.01%
U0-61	State of frequency convertor	1

## Chapter 6 Parameter description

P0 group : Basic function group

P0-00	Display of GP type		Factory default	Related to machine type
	Setting range	1	G type (load of constant torque)	
		2	P type (load of fan and pump load)	

The parameter is just for users to view machine type and can't be changed.

1: be suitable for constant torque load of designated rated parameters

2: be suitable for variable torque load of designated rated parameters (load of fan and pump)

P0-01	Control mode of 1 <sup>st</sup> motor		Factory default	0
	Setting range	0	No speed Sensor vector control (SVC)	
		1	Speed sensor vector control (FVC)	
		2	V / F control	

0: No speed Sensor vector control

The open-loop vector control is suitable for general high-performance control applications. One frequency convertor can only drive one motor such as load of machine tools, centrifuges, wire drawing machine, injection molding machine, etc.

1: Speed sensor vector control is a closed loop vector control. Motor-side must be installed with encoder. The frequency convertor must be machted with the same type of PG card with encoder. It is suitable for high-precision speed control or torque control applications. One inverter can only drive one motor such as load of paper-making machinery, cranes, elevators, etc.

2: V / F control is suitable for the oaccasion with less demand on load, or one frequency convertor drives multiple motors such as fans and pumps load. It can be used for one frequency convertor to drive multiple motors.

Prompt: motor parameter identification procedure is required when selecting vector control mode. Only accurate motor parameters can take advantage of the vector control mode. By adjusting the parameters of speed regulator in function code in P2 group (2 is second group), better performance can be achieved.

P0-02	Command source selection		Factory default	0
	Setting range	0	Operation panel command channel (LED off)	
		1	Terminal command channel (LED lights)	
		2	Command channel (LED flashes)	

Select input channel of control command of frequency convertor.

Control commands of frequency convertor include: start, stop, forward, reverse, jog and so on.

0: Operation panel command channel ("LOCAL / REMOT" Lights off);

On the control panel, the RUN, STOP / RES keys perform running command control.

1: Terminal command channel ("LOCAL / REMOT" Lights on);

Multifunctional input terminals FWD, REV, JOG, JOG, etc., run command control.

2: Command channel ("LOCAL / REMOT" Blinking) Running command is given by the host computer via the communication mode.

When it is selected, communication card must be optional (Modbus RTU, CANlink card, user-programmable control card, etc.).

P0-03	Main frequency source X	Factory default	0	
	Setting range	0	Digital setting (Preset frequency P0-08, UP/DOWN is modified, memory after power failure)	
		1	Digital setting (Preset frequency P0-08, UP/DOWN is modified, no memory after power failure)	
		2	AI1	
		3	AI2	
		4	AI3	
		5	PULSE setting (DI5)	
		6	Multi-stage command	
		7	PLC	
		8	PID	
9		Communication given		

Select input channel of given frequency of converter. There are 10 main reference frequency channels:  
 0: Digital setting (no memory after power failure)

Value that its set frequency initial value is P0-08 “preset frequency.” Through the ▲ ▼ keys (or multi-function input terminal UP, DOWN) to change the set frequency value.

And when the converter is power-on after power failure, frequency setting value recovers “digital setup preset frequency” as the value P0-08.

1: Digital setting (memory after power failure)

Value that its set frequency initial value is P0-08 “presets frequency”. By keyboard ▲, ▼ buttons (or multi-function input terminal UP, DOWN) to change the set frequency value.

And when the converter is power-on after power failure, the set frequency is the frequency last power set by keyboard ▲, ▼ keys or terminals UP, DOWN correction is memorized.

It needs to be reminded that P0-23 is “digital setting frequency down memory selection”, P0-23 is used for selecting when the drive is stopped, choose the correction amount or frequency of the memory. P0-23 is related to downtime, and power-down memory is not related. You need to pay attention for application.

2: AI1

3: AI2

4: AI3

It means that the frequency is set by analog input terminal to determine. VFD-200G control panel provides two analog input terminals (AI1, AI2), Optional I / O expansion card provides an additional analog input terminal (AI3).

Among them, AI1 is 0V ~ 10V voltage input, AI2 can be 0V ~ 10V voltage input, It may also be 4mA ~ 20mA current input. It is selected by J8 jumper on the control panel, AI3 is -10V ~ 10V voltage input.

Correspondence between the input voltage AI1, AI2, AI3, the target frequency, the user can freely choose. VFD-200G provides 5 group of correspondence between the curves, including 3 Group curve of linear relationship (2 point correspondence), 2 group of any 4 points curve correspondence. User groups can be set via P4 and A6 group function code.

P4-33 function code is used to set AI1 ~ AI3 three-way analog input. Select any curve in the 5 group, and then the detailed correspondence of the 5 group of curves please refer to P4 and A6 Group Function Code instructions.

5: Pulse given (DI5)

Frequency setting is given by the terminal pulse. Pulse reference signal specification: voltage range 9V ~ 30V, frequency range 0kHz ~ 100kHz. Pulse reference can only be entered from the input terminal DI5 multifunction.

Relations DI5 terminal input pulse frequency corresponding to the set, and set by P4-28 ~ P4-31. The correspondence between the two points is a straight line corresponding relationship. Pulse input corresponding set is 100.0%, which means the percentage of relative maximum frequency P0-10.

6: Multi-stage instruction

When selecting the multi-instruction execution mode, You need to enter the DI terminals via digital composition different states corresponding to different frequencies of the set value. VFD-200G can set up more than four segments command terminal, 16 states four terminals, PC function code can be corresponding to any of 16 “multi-directive”. Multi-directive” is the relative percentage of the maximum frequency P0-10.

DI digital input terminal as a multi-function terminal block command, you need to set the corresponding group P4. For details, please refer to the relevant function parameter of group P4.

7: Simple PLC

When the frequency source is simple PLC, Running frequency of the inverter can be switched to run between 1 to 16 arbitrary frequency command. Retention time of 1 to 16 frequency command and the respective acceleration and deceleration time can be set by the user. For detailed contents refers to relative instructions of PC group.

8: PID

Selection process PID control output is used as the operating frequency. Generally used for on-site closed-loop control process, Such as closed-loop control of constant pressure, constant tension closed-loop control applications and other conditions.

When applying PID as the frequency source, You need to set the PA group “PID function” parameters.

9: Communication given

Refers to the main frequency source is the host computer via the communication mode.

VFD-200G supports two kinds of communication: Modbus. CANlink, These two kinds of communication can not be used.

Communication card must be installed when using communication, VFD-200G two kinds of communication cards are optional, Users need to choose according to their own requirements, And you need to set the correct parameters for P0-28 “communication expansion card type.”

Auxiliary frequency source Y		Factory default	0
P0-04	Setting range	0	Digital setting (Preset frequency P0-08, UP/DOWN is modified, memory after power failure)
		1	Digital setting (Preset frequency P0-08, UP/DOWN is modified, no memory after failure)
		2	AI1
		3	AI2
		4	AI3
		5	PULSE setting (DI5)
		6	Multi-stage command
		7	PLC
		8	PID
		9	Communication given

Specification of VFD-200G high-performance vector convertor Parameter

When auxiliary frequency source is used as independent frequency reference channel (that is to say frequency source X to Y switching), Its usage is same with main frequency source X. Usage instructions can refer to the P0-03.

When the auxiliary frequency source is used as the superposition given (ie frequency source X + Y, X to X + Y switch or Y to X + Y switch), you need pay attention to:

1) When the auxiliary frequency source is digital reference, preset frequency (P0-08) does not work. User via keyboard ▲, ▼ buttons (or multi-function input terminal UP, DOWN) to conduct frequency adjustment. Adjust directly on the basis of the main reference frequency.

2) When the auxiliary frequency source is given by analog input (AI1, AI2, AI3) or pulse input to the timing, 100% corresponds to the input setting auxiliary frequency source range can be set by P0-05 and P0-06.

3) When frequency source is used as pulse input timing, it is similar with analog given. Prompt: Auxiliary frequency source Y selection and the main frequency source X selection can not be set in one channel, That is to say P0-03 and P0-04 are set to the same value. Or it is easy to lead to confusion.

P0-05	Auxiliary superimposed frequency source Y range		Factory default	0
	Setting range	0 1	Relative to the maximum frequency Relative to frequency source X	
P0-06	Auxiliary superimposed frequency source Y range		Factory default	0
	Setting range		0%~150%	

When the frequency source selection is “frequency overlay” (ie P0-07 is set to 1, 3 or 4), These two parameters are used to determine the adjustment range of auxiliary frequency source.

When P0-05 is used to determine object auxiliary frequency range corresponding to the source, selectively with respect to the maximum frequency to be relative to the main frequency source X. If you choose relative to the primary frequency source, the auxiliary frequency source is used as the main frequency range of X changes.

P0-07	Frequency source superimposed selection		Factory default	0
	Setting range	Bit	Frequency source selection	
		0	Main frequency source X	
		1	Main and auxiliary operation result	
		2	Switch of main frequency source X and auxiliary frequency source Y	
		3	Main frequency source X, main and auxiliary operation result switch	
		4	Auxiliary frequency source Y, main and auxiliary operation result switch	
		Ten bit	operation relation of main and auxiliary frequency source	
		0	Main + auxiliary	
		1	Main-auxiliary	
2		Max. of the two		
3	Min. of the two			

Through this parameter to select the frequency reference channel. Realized by frequency composite primary frequency source X and auxiliary frequency source Y are given.

Single digit: Frequency source selection:

0: Main frequency source X

Main frequency X is used as the target frequency.

1: Main and auxiliary operation result Main and auxiliary operation result as the target frequency. See the main and auxiliary operation relations function code “Ten Bit” instructions.

2: Switch of main frequency source X and auxiliary frequency source Y. When multi-function input terminal 18 is (frequency switch) invalid, main frequency source X is target frequency. When multi-



Parameter description Specification of VFD-200G high-performance vector

function input terminal 18 is (frequency switch) valid, auxiliary frequency source Y is target frequency.

3: Switch of main frequency source X and main & auxiliary operation result. When multi-function input terminal 18 is (frequency switch) invalid, main frequency source X is target frequency. When multi-function input terminal 18 is (frequency switch) valid, main & auxiliary operation result is target frequency.

4. Switch of auxiliary frequency source Y and main & auxiliary operation result. When multi-function input terminal 18 is (frequency switch) invalid, auxiliary frequency source Y is target frequency. When multi-function input terminal 18 is (frequency switch) valid, main & auxiliary operation result is target frequency.

Ten bit: Main and auxiliary frequency source operational relationship:

0: Main frequency source X + auxiliary frequency source Y

Sum of main frequency X and accessory frequency Y is used as the target frequency. Achieve frequency superposition given feature.

1: Main frequency source X- auxiliary frequency source Y

The difference between main frequency source X and auxiliary frequency source Y is used as target frequency.

2: MAX (Main frequency source X, the auxiliary frequency source Y) Take the maximum absolute value of main frequency X and accessory frequency Y as the target frequency.

3: MIN (Main frequency source X, the auxiliary frequency source Y) Take the minimum absolute value of main frequency X and accessory frequency Y as the target frequency. In addition, When the frequency source selection is main and auxiliary operations, offset frequency can be set by P0-21. Offset frequency superimposed on the main and auxiliary operation result to respond flexibly to various needs.

4: MIN (Main frequency source X, the auxiliary frequency source Y) Take the minimum absolute value of main frequency X and accessory frequency Y as the target frequency. In addition, When the frequency source selection is main and auxiliary operations, offset frequency can be set by P0-21. Offset frequency superimposed on the main and auxiliary operation result to respond flexibly to various needs.

P0-08	Preset frequency	Factory default	50.00Hz
	Setting range	0.00~max. frequency (frequency source selection mode to digital setting is effective)	

When the frequency source is selected for the “Digital setup” or “terminal UP / DOWN”, the digital frequency inverter function code is the initial setting value.

P0-09	Running direction	Factory default	0
	Setting range	0	Same direction
		1	Opposite direction

By changing the function code, it can not change the electrical wiring and achieve the purpose of changing the motor rotation. Which acts to adjust the motor (U, V, W) to convert any two lines of the motor rotation direction.

Prompt: After initialization of parameter, motor running direction will restore the original state. Be caution to use it in the condition that after the system is debugged, the motor steering is strictly prohibited to change.

P0-10	Max. frequency	Factory default	50.00 Hz
	Setting range	50.00Hz~600.00Hz	

VFD-200G analog input, pulse input (DI5), multi-step instructions, etc., as the frequency source is 100.0% relative to the respective scaling P0-10.

VFD-200G maximum output frequency is up to 3200Hz. As to take into account for the frequency resolution and frequency input range for both indicators, it may select frequency instruction decimal places by P0-22.

When P0-22 is selected as 1, the frequency resolution is 0.1Hz. In this case P0-10 is set in the range of 50.0Hz ~ 3200.0Hz;

When P0-22 is selected as 2, the frequency resolution is 0.1Hz. In this case P0-10 is set in the range of 50.0Hz ~ 600.00Hz.

P0-11	Upper frequency source	Factory default	0
	Factory default	0	P0-12 setting
		1	AI1
		2	AI2
		3	AI3
		4	PULSE setting
5	Communication given		

Define the source of the upper frequencies. Upper limit frequency can be set from the digital (P0-12), It can also be derived from the analog input channel. When setting the upper limit frequency analog input, analog input setting's 100% corresponds to P0-12.

For example, when adopting torque control mode in the field of winding control, as to avoid breaking the material and appearing "speed" phenomenon, you can use the analog set frequency caps. When the inverter runs at the frequency upper limit, The inverter remains its running in the upper frequency.

P0-12	Upper frequency	Factory default	50.00Hz
	Setting range	Upper frequency P0-14~maximum frequency P0-10	
P0-13	Upper frequency offset	Factory default	0.00Hz
	Setting range	0.00Hz~maximum frequency P0-10	

When the upper limit frequency is the analog or pulse setting, P0-13 is used as the set value of the offset. The bias frequency and P0-11 set an upper limit frequency superimposed on the set value as the final upper limit frequency.

P0-14	Lower frequency	Factory default	0.00Hz
	Setting range	0.00Hz~upper frequency P0-12	

When frequency command below the lower frequency set by P0-14, the inverter can stop or lower limit frequency operation or zero speed running. What kind of operation mode shall be selected can be (setting frequency below the lower frequency operation mode) set by P8-14.

P0-15	Carrier frequency	Factory default	Related to machine type
	Setting range	0.5kHz~16.0kHz	

This function adjusts the carrier frequency of the inverter. By adjusting the carrier frequency, it can reduce motor noise, avoid the resonance point of the mechanical system, and reduce interference and line-to-ground leakage current of the inverter.

When the carrier frequency is low, output current higher harmonic component increases, motor loss increases, and motor temperature increases. When the carrier frequency is high, motor loss decreases, motor temperature decreases, But the inverter loss increases, inverter temperature increases and interference increases.

Carrier frequency adjustment will affect the following properties:

Carrier frequency	Low → high
Motor noise	Large → small
Output current waveform	Bad → good
Temperature rise of motor	High → low
Temperature rise of convertor	Low → high
Leakage current	Small → large
External radiated interference	Small → large

For different power inverters, carrier frequency's factory settings are different. Although users can modify, but note: If the value of the carrier frequency is higher than the factory set, it will cause the

Parameter description Specification of VFD-200G high-performance vector inverter heat sink temperature increase. In this case the user needs to derating for the inverter, or there is the danger of overheating inverter alarm.

P0-16	Carrier frequency adjusts with temperature	Factory default	0
	Setting range	0: no 1: yes	

Carrier frequency temperature adjustment means when the inverter detects its own heat sink temperature is high, it will automatically reduce the carrier frequency in order to reduce the temperature rise of the inverter. When the heat sink temperature is low, the carrier frequency is gradually restored to the set value. This feature can reduce the chance of inverter overheating alarm.

P0-17	Acceleration time 1	Factory default	Depend on machine type
	Setting range	0.00s~65000s	
P0-18	Deceleration time 1	Factory default	Depend on machine type
	Setting range	0.00s~65000s	

Acceleration time means the needed time for the inverter accelerating from zero frequency to acceleration and deceleration reference frequency (P0-25 determination). See t1 in Figure 6-1. Deceleration time means the needed time for the inverter decelerating from acceleration and deceleration reference frequency (P0-25 determination) to zero frequency. See t2 in Figure 6-1.

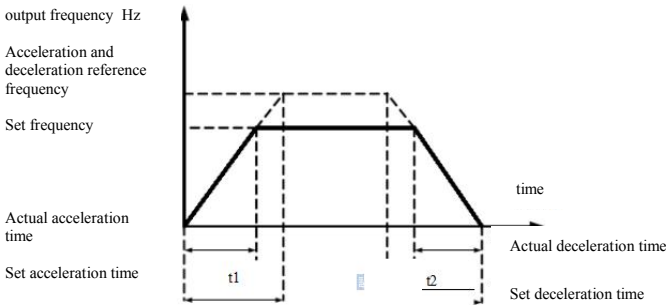

Figure 6-1 Diagram of acceleration and deceleration time

VFD-200G provide four group of acceleration and deceleration time. Users can take advantage of the digital input terminal DI toggle. Four group of acceleration and deceleration time set by function code are as follows:

- First group: P0-17, P0-18
- Second group: P8-03, P8-04
- second group: P8-05, P8-06
- Fourth group: P8-07, P8-08

P0-19	Acceleration/Deceleration time unit	Factory default	1
	Setting range	0	1s
		1	0.1s
	2	0.01s	

As to meet the needs of all types of site, VFD-200G provides three kinds of acceleration and deceleration time units, respectively are 1 second, 0.1 seconds and 0.01 seconds.

Note: When modify the function parameters, Group 4 decimal places will change the displayed acceleration and deceleration time, Corresponding to the acceleration and deceleration time changes, pay special attention to the application process.

P0-21	Auxiliary superimposed frequency source bias frequency	Factory default	0.0Hz
	Setting range	0.00Hz~maximum frequency F0-10	

The function code is only valid when the the frequency source selection is main and auxiliary calculation.

When the frequency source is the main and auxiliary calculation, P0-21, as an offset frequency, And primary and secondary operation are used as the final result of the superposition frequency setpoint to make the frequency setting more flexible.

P0-22	Resolution of frequency command		Factory default	2
	Setting range	1	0.1Hz	
		2	0.01Hz	

This parameter is used to identify all frequency-dependent function code resolution.

When the frequency resolution is 0.1Hz when, VFD-200G maximum output frequency can reach 3200Hz. When the frequency resolution is 0.01Hz, the maximum output frequency VFD-200G is 600.00Hz.

Attention: When you modify the function parameters, all the parameters related decimal places of frequency will change. The corresponding frequency values shall also change, pay special attention when using.

P0-23	Digital setting frequency stop memory selection		Factory default	0
	Setting range	0	No memory	
		1	Memory	

This function is only effective when the frequency source is set as numbers.

“No memory” means after inverter stops, digital set frequency value back to P0-08 (preset frequency) values. Keyboard ▲, ▼ keys or terminals UP, DOWN frequency correction performed is cleared.

“Memory” means after inverter stops, digital set frequency reserved for the last stop time set frequency. Frequency keyboard ▲, ▼ keys or terminals UP, DOWN conduct correction remains valid.

P0-24	Motor selection		Factory default	0
	Setting range	0	Motor 1	
		1	Motor 2	

VFD-200G supports drag-sharing drive 2 motors application. 2 motors can respectively set the motor nameplate, independent tuning parameters, choose a different control mode, independent setting performance related parameters and others.

Corresponding function parameter group of motor 1 is P1 group and P2 group. Corresponding function parameter group of motor 2 is A2 group.

The user to select current motor through P0-24 function code, you can also switch the motor through the input terminal DI digital. When the function code selection and terminal selection have contradiction, the terminal selection shall prevail.

P0-25	Acceleration/Deceleration time reference frequencies		Factory default	0
	Setting range	0	Maximum frequency (P0-10)	
		1	Set frequency	
		2	100Hz	

Acceleration and deceleration time means the acceleration and deceleration time from zero frequency to P0-25 setting frequency. Figure 6-1 is the Acceleration and Deceleration Time Schematic.

When P0-25 is selected as 1, deceleration time and frequency related to the set. If setting frequency change frequently, the motor acceleration is changeable, so we need to pay attention to the application.

P0-26	Frequency command in operation UP/DOWN standard		Factory default	0
	Setting range	0	Operating frequency	
		1	Set frequency	

Parameter description Specification of VFD-200G high-performance vector

This parameter is valid only when the frequency source is digital setting.

When keyboard is used to determine the ▲, ▼ buttons or terminal UP / DOWN action, adopt any manner in which the frequency correction is set, That target frequency increases or decreases based on the operating frequency or based on the set frequency.

Difference between the two settings performs significantly when the inverter is in the process of acceleration and deceleration. That is, if the operating frequency and the set frequency of the inverter are not the same, the difference between different parameter selection will be large.

P0-27	Frequency source and command source in bundle		Factory default	000
	Setting range	Bit	Operation panel command binds frequency source	
		0	Unbound	
		1	Digital set frequency	
		2	AI1	
		3	AI2	
		4	AI3	
		5	Digital set frequency	
		6	Multi-stage command	
		7	Simple PLC	
		8	PID	
		9	Communication given	
		Ten bit	Terminal command binds frequency source (0~9, same as bit)	
	Hundred bit	Communication command binds frequency source (0~9, same as bit)		

It defines the bundle of three run command channel and nine given frequencies between channels, and it is easy for the realization of synchronous switch.

The above frequencies given channel meaning is same with main frequency source X selection P0-03. See the description of function code P0-03. Different modes can be bundled with the same frequency given channel. When the command frequency source has bundled source, in the effective period of the command source, P0-03 ~ P0-07 set frequency source no longer works.

P0-28	Communication expansion card type		Factory default	0
	Setting range	0	Modbus communication card	
		1	Spare	
		2	Spare	
		3	CANlink communication card	

VFD-200G provides two kinds of communication. This communication requires an optional communication card before use, and two kinds of communication can not be used at same time.

This parameter is used to set the type of the optional communication card. When the user to replace the communications card, you must set the parameters correctly.

P1 group: Parameters of 1<sup>st</sup> motor

P1-00	Type selection of motor	Factory default	0
	Setting range	0	Common asynchronous motor
		1	Variable frequency asynchronous motor
P1-01	Rated power	Factory default	Depend on machine type
	Setting range	0.1kW~1000.0kW	
P1-02	Rated voltage	Factory default	Depend on machine type
	Setting range	1V~400V	
P1-03	Rated current	Factory default	Depend on machine type
	Setting range	0.01A~655.35A (converter power <=55kW) 0.1A~6553.5A (converter power >55kW)	
P1-04	Rated frequency	Factory default	Depend on machine type
	Setting range	0.01Hz~max. frequency	
P1-05	Rated speed	Factory default	Depend on machine type
	Setting range	1rpm~65535rpm	

The code for the motor nameplate parameters, both by VF control and vector control, are needed to accurately set the relevant parameters according to the motor nameplate.

In order to obtain better VF or vector control performance, the need for parameter tuning, and the accuracy of adjustment results, and properly set motor nameplate parameters closely.

P1-06	Stator resistance of asynchronous motor	Factory default	Depend on machine type
	Setting range	0.001Ω~30.000Ω	
P1-07	Rotor resistance of asynchronous motor	Factory default	Depend on machine type
	Setting range	0.001Ω~65.535Ω (converter power <=55kW) 0.0001Ω~6.5535Ω (converter power >55kW)	
P1-08	Leakage inductive reactance of asynchronous motor	Factory default	Depend on machine type
	Setting range	0.01mH~655.35mH (converter power <=55kW) 0.001mH~65.535mH (converter power >55kW)	
P1-09	Mutual inductive reactance of asynchronous motor	Factory default	Depend on machine type
	Setting range	0.1mH~6553.5mH (converter power <=55kW) 0.01mH~655.35mH (converter power >55kW)	
P1-10	No-load current of asynchronous motor	Factory default	Depend on machine type
	Setting range	0.01A~P1-03 (converter power <=55kW) 0.1A~P1-03 (converter power >55kW)	

P1-06 ~ P1-10 is asynchronous motor parameters, these parameters generally do not have the motor nameplate, auto-tuning to get through the drive. Among them, “Induction Motor static tuning” can only get three parameters P1-06 ~ P1-08. But the “asynchronous motors complete tuning” can be obtained here except all five parameters, you can also get the encoder phase sequence, current loop PI parameters and others.

Parameter description Specification of VFD-200G high-performance vector

When changing motor rated power (P1-01) or the motor rated voltage (P1-02), the inverter will automatically modify the parameter value P1-06 ~ P1-10, and make these five parameters back to the usual standard Y series motor parameters.

If the site induction motor can not be tuned, you may according to the parameters provided by the manufacturer of the motor, input the corresponding function code.

P1-27	Encoder line number	Factory default	1024
	Setting range	1~65535	

Setting ABZ encoder pulses per revolution.

In the case of speed sensorless vector control mode, you must set the correct number of encoder pulses, or the motor will not operate properly.

P1-28	Encoder type	Factory default	0
	Setting range	0	ABZ incremental encoder
		1	Spare
		2	Rotary transformer

VFD-200G supports multiple encoder types. Different encoders require matching different PG cards. Please choose the right PG card to use.

After installing the PG card, properly set P1-28 according to the actual situation, or the inverter may not operate properly.

P1-30	ABZ incremental encoder AB phase sequence	Factory default	0
	Setting range	0	Forward
		1	Reverse

This function code is only valid for the ABZ incremental encoder, which is only valid when P1-28 = 0. For setting phase sequence ABZ incremental encoder AB signal.

P1-34	Pole-pairs number of rotary transformer	Factory default	1
	Setting range	1~65535	

Resolver is the number of pole pairs in the use of such an encoder, you must set the parameters number of pole pairs correctly.

P1-36	Speed feedback PG disconnection detection time	Factory default	0.0s
	Setting range	0.0: no action 0.1s~10.0s	

It is used to establish encoder disconnection fault detection time, when set to 0.0s, the inverter will not detect encoder disconnection fault.

When the inverter detects a disconnection fault, and lasts longer than P1-36 set time, the inverter alarm ERR20.

P1-37	Tuning Selection	Factory default	0
	Setting range	0	No operation
		1	Static tuning of asynchronous motor
		2	Complete tuning of asynchronous motor

0: No action, which prohibits tuning.

1: Asynchronous machine static tuning for induction motor and the load is not easy to disengage, but not a complete tuning occasion. Before conducting asynchronous static tuning, you must set the correct motor type and motor nameplate P1-00 ~ P1-05. Asynchronous machine static tuning, the inverter can be obtained P1-06 ~ P1-08 three parameters. Action description: Set the function code is 1, then press the RUN key, the inverter will conduct static tuning.

2: Asynchronous machine Complete tuning. As to ensure the dynamic control performance of the inverter, choose full tuning, the motor must be separated from the load to keep the motor for the no-load condition.

Complete tuning process, the inverter will conduct static tuning, and then follow the acceleration time to accelerate P0-17 to 80% of the motor rated frequency. After the holding period, P0-18 Deceleration according to the deceleration time and stop the tuning is performed before the asynchronous machine complete tuning. In addition to the need to set the motor type and motor nameplate parameters P1-00 ~ P1-05, but also need to set the correct encoder type and encoder pulses P1-27, P1-28. Asynchronous machine complete tuning, the drive can be obtained P1-06 ~ P1-10 five motor parameters and encoder AB phase sequence P1-30, vector control current loop PI parameters P2-13 ~ P2-16.

Action Description: Set the function code is 2, then press the WIN key, the inverter will complete tuning.

**P2 group: Vector control parameters**

Function code in P2 group is only effective for vector control, not for VF control.

P2-00	Speed loop proportional gain 1	Factory default	30
	Setting range	1~100	
P2-01	Speed loop integral time 1	Factory default	0.50s
	Setting range	0.01s~10.00s	
P2-02	Switching frequency 1	Factory default	5.00Hz
	Setting range	0.00~F2-05	
P2-03	Speed loop proportional gain 2	Factory default	15
	Setting range	0~100	
P2-04	Speed loop integral time 2	Factory default	1.00s
	Setting range	0.01s~10.00s	
P2-05	Switching frequency 2	Factory default	10.00Hz
	Setting range	F2-02~Maximum output frequency	

Drive is running at different frequencies, you can select a different speed loop PI parameters. When operating frequency is smaller than the switching frequency 1 (P2-02), the speed loop PI adjustment parameters are P2-00 and P2-01. When the operating frequency is greater than the switching frequency 2, the speed loop PI adjustment parameters are P2-03 and P3-04. Speed loop PI parameters between switching frequency 1 and switching frequency 2 are the two group of PI parameters linear switching. Shown in Figure 6-2:

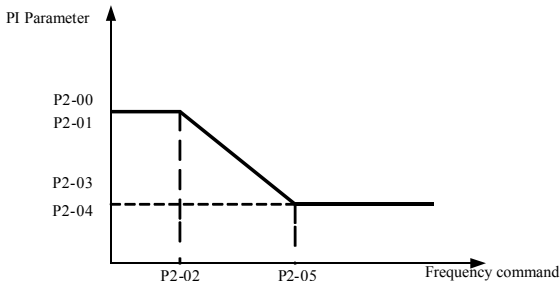

Figure 6-2 Diagram of PI parameters



Parameter description Specification of VFD-200G high-performance vector

Through setting the proportional coefficient of speed regulator and integration time, you can adjust vector control speed dynamic response characteristic.

Increasing the proportional gain, reducing the integration time can accelerate the dynamic response of the speed loop. However, the proportional gain is too large or the integral time too small may cause the system to vibrate. Recommend adjustment method:

If the factory parameters can not meet the requirements, then the value of the parameter in the factory on the basis of fine-tuning. Increase the proportional gain first to ensure that the system does not oscillate; then decrease the integration time, the system has quick response characteristics and small overshoot.

Note: As PI parameters are set incorrectly, it may cause large overshoot speed. Even when students fall overshoot overvoltage fault.

P2-06	Vector control slip gain	Factory	100%
	Setting range	50%~200%	

Speed sensorless vector control This parameter is used to adjust the steady speed precision motor: When the motor load is low to increase the speed parameter, vice versa.

For speed sensor vector control, this parameter can also adjust the load of the inverter output current.

P2-07	Speed loop filter time	Factory	0.000s
	Setting range	0.000s~0.100s	

In vector control mode, the speed loop regulator output torque current command, the parameters for the torque command filter. This parameter is generally no need to adjust the speed fluctuations that may be appropriate to increase the filtering time; If the motor oscillation occurs, it should be appropriate to reduce this parameter.

Speed loop filter time constant is small, the output torque of the drive may be volatile, but the response speed is fast.

P2-08	Vector control over	Factory	64
	Setting range	0~200	

During the deceleration, the over-excitation control bus voltage rise can be suppressed to avoid overvoltage fault. Greater the over excitation gains, stronger the suppression has effect.

For conditions that in the inverter deceleration process, it is easier to be over-pressured and sounds alarm, you need to improve the over excitation gain. But if excitation gain is too large, easily lead the output current to increase; you need to weigh in the application.

For the case of small inertia, deceleration of the motor voltage rise does not appear, it is recommended that the over excitation gain is 0; For braking resistance of the occasion, it is also suggested that over-excitation gain is set to 0.

P2-09	Speed control mode torque limit source	Factory default	0
	Setting range	0	F2-10
		1	AI1
		2	AI2
		3	AI3
		4	PULSE Setting
5	Communication Preferences		
P2-10	Torque limit speed control mode digital set	Factory default	150.0%
	Setting range	0.0%~200.0%	

In speed control mode, the maximum value of the inverter output torque is controlled by the torque limit source.

P2-09 is used to select the source to set the speed limit, when the via analog, pulse, communication settings, 100% corresponds to the appropriate setting P2-10, P2-10 and 100% of the inverter rated torque.

P2-13	Excitation regulator proportional gain	Factory default	2000
	Setting range	0~20000	
P2-14	Excitation regulation integral gain	Factory default	1300
	Setting range	0~20000	
P2-15	Torque control proportional gain	Factory default	2000
	Setting range	0~20000	
P2-16	Torque control integral gain	Factory default	1300
	Setting range	0~20000	

Vector control current loop PI adjustment parameters. The complete tuning parameters in an asynchronous machine or synchronous machine will automatically load after tuning, generally do not need to modify.

What needs to be reminded is that the current loop integral controller, instead of using the integration time as a dimension, but directly set the integral gain. PI current loop gain is set too high, it may cause the entire control loop oscillation, so when current oscillations or torque ripple is large, it can be reduced manually for PI proportional gain or integral gain here.

### P3 group-V/F control parameters

The function code only for V / F control is effective. For vector control, it is invalid.

V / F control is suitable for fans, pumps and other general load, or a inverter with multiple motors, or inverter power and motor power quite different applications.

		V/F curve setting	Factory default	0
P3-00	Setting range	0	Straight line V / F	
		1	More V / F	
		2	Square V / F	
		3	1.2 times V / F	
		4	1.4 times V / F	
		6	1.6 times V / F	
		8	1.8 times V / F	
		9	Retention	
		10	VF Complete separation mode	
		11	VF Semi-separation mode	

0: Linear V / F. Suitable for ordinary constant torque load.

1: Multi-point V / F. Suitable for dehydration machines, centrifuges and other special loads. At this time by setting P3-03 ~ P3-08 parameters, it can be obtained at any of VF curve.

2: Multi-point V / F. Suitable for fans, pumps and other centrifugal load.

3~8: VF curve between the straight line between the PF and VF square.

10: VF completely separate mode. Then the output frequency of the inverter output voltage independent of each other, the output frequency is determined by the frequency source. But output voltage is determined by P3-13 (VF isolated voltage source).

VF complete separation mode, Generally used in induction heating, power inverter, torque motor control and other applications.

11: VF semi-separation mode.

In this case V and F are proportional, but proportional to the voltage source by setting P3-13, and the relationship between V and F are also group P1 rated motor voltage related to the rated frequency.

Parameter description Specification of VFD-200G high-performance vector

Suppose the input voltage source is X (X is 0 to 100% of the value), the output voltage V F of the relationship between the inverter and the frequency is:

$$V / F = 2 * X * (\text{Motor rated voltage}) / (\text{rated motor frequency})$$

P3-01	Torque boost	Factory default	Model confirmation
	Setting range	0.0% ~ 30%	
P3-02	Cut-off frequency of torque	Factory default	50.00Hz
	Setting range	0.00Hz ~ maximum output frequency	

As to compensate for V / F control low frequency torque characteristics, make increase compensation for the low-frequency inverter output voltage. However, the torque boost is set too large, the motor overheating, inverter over-current.

When the load is heavy and the motor starting torque is not enough, it is recommended to increase this parameter. Light can be reduced when the load torque boost. When the torque boost is set to 0.0, the inverter is automatic torque boost, torque boost at this time according to the drive motor stator resistance parameters calculated automatically required.

Torque boost Torque cut-off frequency: Under this frequency, torque boost torque is effective. More than this set frequency, torque boost will failure. See details in Figure 6-3.

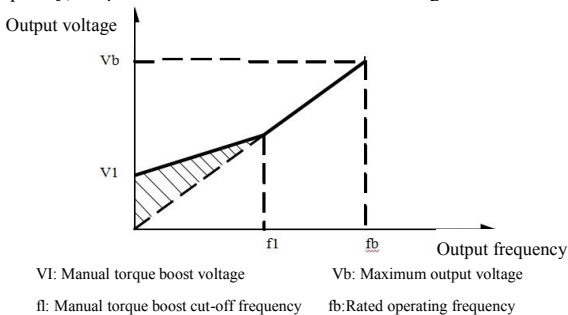

Figure 6-3 Diagram of manual torque boost

P3-03	Multi-VF frequencies F1	Factory default	0.00Hz
	Setting range	0.00Hz ~ P3-05	
P3-04	Multi-VF Voltage point V1	Factory default	0.0%
	Setting range	0.0% ~ 100.0%	
P3-05	Multi-VF frequencies F2	Factory default	0.00Hz
	Setting range	P3-03 ~ P3-07	
P3-06	Multi-VF Voltage point V2	Factory default	0.0%
	Setting range	0.0% ~ 100.0%	
P3-07	Multi-VF frequencies F3	Factory default	0.00Hz
	Setting range	P3-05 ~ motor rated frequency (P1-04) Note: second motor rated frequency is A2-04	
P3-08	Multi-VF Voltage point V3	Factory default	0.0%
	Setting range	0.0% ~ 100.0%	

P3-03 ~ P3-08 six parameters to define multi-segment V / F curve.

Multi-point curve V / F should be set according to the load characteristics of the motor. What need to be aware of is that, Relationship between the voltage and frequency three points points must be met:  $V1 < V2 < V3$ ,  $F1 < F2 < F3$ . Figure 6-4 is a schematic view of multi-point setting VF curve.

Voltage is set too high may cause motor overheating and even burned at low frequencies, the drive may be too stall or over-current protection.

P3-09	VF slip compensation gain	Factory default	0
	Setting range	0%~200.0%	

VF Slip compensation. It can be compensated induction motor generated when the load increases the motor speed deviation when the load changes the motor speed can be stable.

VF Slip compensation gain is set to 100.0%, indicating that slip when the motor with a rated load compensation to the motor rated slip. But the motor rated slip, the drive motor rated frequency group by P1 and rated speed to get own calculations.

Adjust VF rpm slip compensation gain, generally when the rated load, the motor speed and the target speed is substantially the same as the principle. When the motor speed and the target value is not the same, you need to be properly fine-tune the gain.

P3-10	VF over excitation gain	Factory default	6
	Setting range	0~200	

During the deceleration, the over-excitation control bus voltage rise can be suppressed to avoid overvoltage fault. Greater the over excitation gains, stronger the suppression has effect.

For conditions that in the inverter deceleration process, it is easier to be over-pressured and sounds alarm, you need to improve the over excitation gain. But if excitation gain is too large, easily lead the output current to increase; you need to weigh in the application.

For the case of small inertia, deceleration of the motor voltage rise does not appear, it is recommended that the over excitation gain is 0; For braking resistance occasion, it is also suggested that over-excitation gain is set to 0.

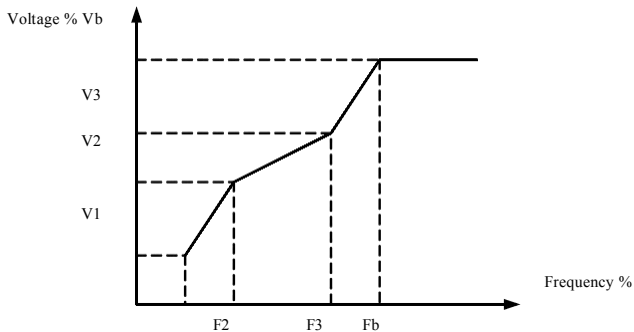

V1-V3: Multi-speed V / F voltage percentage of segment 1-3

F1-F3: Multi-speed V / F frequency percentage of segment 1-3

Vb: Motor rated voltage Fb: motor rated operating frequency

Figure 6-4 Diagram of multi-point V / F curve setting

P3-11	VF oscillation suppression gain	Factory default	Model confirmation
	Setting range	0~100	

The gain selection method is effective in suppressing oscillation, try to take small, so as not to adversely affect the VF operation. When the motor has no oscillation, select this gain as 0. Only when the motor has obvious oscillation only be appropriate to increase the gain, the greater the gain, the oscillation suppression result.

When using the oscillation suppression function requires the motor rated current and no-load current parameters to be accurate, or VF oscillation suppressing effect is not good.

P3-13	VF Isolated voltage	Factory default	0	
	Setting range	0	Digital setting (P3-14)	
		1	AI1	
		2	AI2	
		3	AI3	
		4	Pulse setup (DI5)	
		5	Multi-step instructions	
		6	Simple PLC	
		7	PID	
		8	Communication given	
100.0% Corresponds to the motor rated voltage (P1-02, A4-02, A5-02, A6-02)				
P3-14	VF isolated digital voltage setting	Factory default	0V	
	Setting range	0V ~ motor rated voltage		

VF separation generally used in induction heating, power inverter and torque motor control applications. When choosing VF separation control, the output voltage can be set by function code P3-14, but also from analog, multi-instruction, PLC, PID or communication given. When set to a non-digital, each set corresponding to 100% of rated voltage of the motor, when the percentage of the absolute value of the analog output setting, etc. is negative. So places is set as an active setpoint.

0: Digital setting (P3-14) voltage is directly set by P3-14.

1: AI1    2: AI2    3: AI3

Voltage from the analog input terminal to determine.

4. Pulse setup (DI5) given via the terminal voltage pulse given. Pulse reference signal specification: voltage range 9V ~ 30V, frequency range 0kHz ~ 100kHz.

5. When multi-source voltage instruction multistage instruction, set the group P4 PC and set parameters to determine if a given signal and the reference voltage correspondence.

6. Simple PLC

When the voltage source is simple PLC, need to set the PC set of parameters to determine if a given output voltage.

7. PID

According PID closed loop generates an output voltage. See details PA group PID introduction.

8. Communication refers to the voltage given by the host computer via the communication mode. When the voltage source selection 1-8, 0 corresponds to 100% of the output voltage of 0V ~ motor rated voltage.

P3-14	VF isolated voltage rise time	Factory default	0.0s
	Setting range	0.0s~1000.0s	

VF separation rise time refers to the output voltage changes from 0V to rated motor voltage required time. Shown in Figure 6-5:

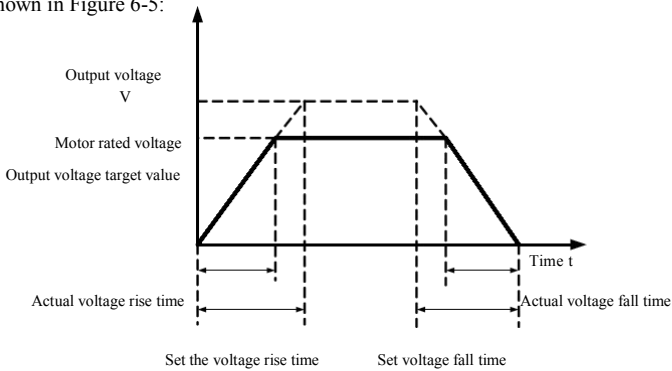

Figure 6-5 Diagram of V/F separation

P4 group: Input terminal

VFD-200G series inverter comes standard with five multifunctional digital input terminals (Where DI5 can be used as high-speed pulse input terminal). Two analog input terminals. If the system needs more input and output terminals can be optional multifunctional input and output expansion card.

Multi-function input and output expansion card has five multifunctional digital input terminals (DI6~DI10), An analog input terminal (AI3).

P4-00	DI1Terminal function selection	Factory default	1 (running)
P4-01	DI2Terminal function selection	Factory default	4 (positive turning point move)
P4-02	DI3Terminal function selection	Factory default	9 (fault reset)
P4-03	DI4Terminal function selection	Factory default	12 (multi speed 1)
P4-04	DI5Terminal function selection	Factory default	13 (multi speed 2)
P4-05	DI6Terminal function selection	Factory default	0
P4-06	DI7Terminal function selection	Factory default	0
P4-07	DI8Terminal function selection	Factory default	0
P4-08	DI9Terminal function selection	Factory default	0
P4-09	DI10Terminal function selection	Factory default	0

These parameters are used to set the digital multi-function input terminal functions can be selected functions as follows:

Set point	Function	Explanation
0	No function	The terminal will not be used to "No function" to prevent malfunction.
1	Forward running (FWD)	By external terminal to control forward and reverse drive.
2	Reverse running (REV)	
3	Three-wire run control;	This terminal is used to determine the inverter operating mode is a three-line control mode. For details, see function code P4-11 ("terminal command mode") instructions.
4	Forward jog (FJOG)	JOG jog forward running, JOG jog reverse running. Jog frequency jog acceleration and deceleration time refer to the function code P8-00, P8-01, P8-02 description.
5	Turning points (RJOG)	
6	Terminals UP	By external terminals a given frequency modification frequency increment, decrement instruction. Frequency source is set to digital setting, can be adjusted up and down to set the frequency.
7	Terminal DOWN	
8	Free stoppage	Inverter blocks the output, then stop the process from motor inverter control. This way is same with freewheel meaning of the P6-10.
9	Reset (RESET)	Use terminal fault reset function. And RESET function key on the keyboard. This function is used to implement remote fault reset.
10	Pause operation	The inverter is stopped, but all operating parameters are memories. Parameters such as PLC, Wobble parameters, PID parameters. After this terminal signal disappears, the drive back to the state before stopping the run.
11	External fault normally open input	When this signal is sent to the inverter, the inverter reports fault ERR15, troubleshooting and fault protection according to the operation mode (for details to participate in the function code P9-47).
12	Multi-speed terminal 1	By 16 states of the four terminals for speed or 16 other instruction set. 16. for details, see Table 1.
13	Multi-speed terminal 2	
14	Multi-speed terminal 3	
15	Multi-speed terminal 4	
16	Deceleration time selection terminal 1	This four states two terminals, four options to achieve acceleration and deceleration time, for details, see Table 2.
17	Deceleration time selection terminal 2	
18	Frequency source switching	As to switch to select a different frequency source. According to the frequency source selection function code (P0-07) is set when a set between the two frequencies as the source switching frequency source, this terminal is used to switch between two frequency source.
19	UP / DOWN Setting clear (terminal, keyboard)	When the frequency of a given digital frequency reference, this terminal can clear frequency terminal UP / DOWN keyboard or UP / DOWN changed, so that a given frequency back to the set value of P0-08.
20	Running command switching terminal	When the command source is set to terminal control (P0-02 = 1), this terminal can be switched terminal control and keyboard control. When the command source is set to the communication control (P0-02 = 2), this terminal can be switched communication control and keyboard control.
21	Ramp stop	Ensure that the drive is not external signals (except stop command), to maintain the current output frequency.
22	PID Time out	PID is temporarily disabled, the inverter maintains the current frequency output, no longer frequency source PID adjust.
23	PLC State reset	PLC pause in the implementation process, is running again, you can restore the inverter through this terminal to the initial state of simple PLC.
24	Swing frequency pause	Drive to the center frequency output. Wobble function pause.
25	Counter input	Count input terminal of the pulse.
26	Counter reset	Counter clearing processing status.
27	Length count input	Length count input terminal.

Set point	Function	Explanation
28	Length reset	Length clear
29	Torque control disabled	Prohibit the drive torque control, the inverter goes into the speed control mode
30	Pulse (pulse) frequency input (valid only for DI5)	DI5 as a pulse input terminal functions.
31	Retention	Retention
32	Now the DC braking	When this terminal is valid, inverter switching directly to the DC braking state
33	External fault normally closed input	When the normally closed external fault signal into the inverter, the inverter reports fault ERR15 and downtime.
34	Frequency modification enabled	If this function is set to valid, when the frequency is changed, the drive does not respond to change frequency, until the terminal state is invalid.
35	PID action direction takes opposite direction	When this terminal is valid, PID action direction and the direction opposite to the set PA-03
36	Exterior stoppage Terminal 1	When conducting keyboard control, this terminal can be used to stop the inverter, the STOP key on the keyboard equivalent functions.
37	Control command switching terminal 2	For switching between the terminal control and communication control. If the command source is selected as terminal control, the system switches to the communication terminal effective control; Vice versa.
38	PID Points pause	When this terminal is valid, the PID integral regulation pause, but the proportion of PID regulation and differential regulation is still valid.
39	Frequency source X and preset frequency switching	The terminal is enabled, the frequency source X with preset frequency (P0-08) Alternative
40	Frequency source Y and preset frequency switching	The terminal is enabled, the frequency source Y with preset frequency (P0-08) Alternative
41	Motor selection terminal 1	Those two states by two terminals, two sets of motor parameters can switch, for details, see Table 3.
42	Motor selection terminal 2	
43	PID Parameter switch	When PID parameter switching conditions for the DI terminal (PA-18 = 1), this terminal is invalid, PID parameter PA-05 ~ PA-07; PA-15 is used when the terminal is valid ~ PA-17;
44	User-defined fault 1	User-defined fault 1 and 2 are valid, the inverter respectively alarm ERR27 and ERR28, the drive will select P9-49 selected operation mode processing based fault protection action.
45	User-defined fault 2	
46	Speed control / torque control switch	Between the drive torque control and speed control modes. The terminal is invalid, A0-00 (speed / torque control) mode is defined in the drive is running, the terminal is valid and then switches to another mode.
47	Emergency Shutdown	When this terminal is valid, the drive with the fastest speed parking, parking during the current limit in the current set. This function is used to meet when the system is in a state of emergency, the drive needs to stop as soon as possible requirements.
48	Exterior stoppage Terminal 2	In any control mode (the control panel, terminal control, communication control), the terminal can be used to make the inverter is stopped, then the deceleration time is fixed deceleration time 4.
49	DC braking deceleration	When this terminal is valid, the inverter will decelerate to stop DC braking starting frequency, and then switch to the DC braking.
50	The running time is cleared	When this terminal is valid, inverter operation timing of this time is cleared, this feature requires the timed run (P8-42) and run this time is reached (P8-53) with the use.



Parameter description Specification of VFD-200G high-performance vector

Annexed Table 1 Multi-section Instruction's Function Description

More than four segments command terminal, it can be combined into 16 states. Each state corresponds to the 16 16 instruction set values. Specifically as shown in Table 1:

K <sub>4</sub>	K <sub>3</sub>	K <sub>2</sub>	K <sub>1</sub>	Instruction set	Corresponding parameters
OFF	OFF	OFF	OFF	Multi segment instruction 0	PC-00
OFF	OFF	OFF	ON	Multi segment instruction 1	PC-01
OFF	OFF	ON	OFF	Multi segment instruction 2	PC-02
OFF	OFF	ON	ON	Multi segment instruction 3	PC-03
OFF	ON	OFF	OFF	Multi segment instruction 4	PC-04
OFF	ON	OFF	ON	Multi segment instruction 5	PC-05
OFF	ON	ON	OFF	Multi segment instruction 6	PC-06
OFF	ON	ON	ON	Multi segment instruction 7	PC-07
ON	OFF	OFF	OFF	Multi segment instruction 8	PC-08
ON	OFF	OFF	ON	Multi segment instruction 9	PC-09
ON	OFF	ON	OFF	Multi segment instruction 10	PC-10
ON	OFF	ON	ON	Multi segment instruction 11	PC-11
ON	ON	OFF	OFF	Multi segment instruction 12	PC-12
ON	ON	OFF	ON	Multi segment instruction 13	PC-13
ON	ON	ON	OFF	Multi segment instruction 14	PC-14
ON	ON	ON	ON	Multi segment instruction 15	PC-15

When the frequency source selection for the multispeed function code PC-00 ~ PC-15 of 100.0%, corresponding to the maximum frequency P0-10. Multi-step instructions except as a multi-speed function, but also can be used as PID given source, or as a voltage source VF separation control, etc., to meet the needs of different between a given value in switching.

Annexed Table 2 Acceleration and deceleration time selection terminal functions

Terminal 2	Terminal 1	Acceleration or deceleration time selection	Corresponding
OFF	OFF	Acceleration time 1	P0-17、P0-18
OFF	ON	Acceleration time 1	P8-03、P8-04
ON	OFF	Acceleration time 3	P8-05、P8-06
ON	ON	Acceleration time 4	P8-07、P8-08

Annexed Table 3 Motor selection Terminal functions

Terminal 2	Terminal 1	Motor selection	Corresponding parameter set
OFF	OFF	Motor 1	P1, P2 Group
OFF	ON	Motor 2	A2 Group

P4-10	DI filtering time	Factory	0.010s
	Setting	0.000s~1.000s	

Setting DI status of the terminal software filter time. If you are using the occasion input terminal susceptible to interference caused by malfunction of this parameter can be increased in order to enhance the anti-jamming capability. While this increases filter time can cause slow response DI terminal.

<b>P4-11</b>	Terminal command mode		Factory default	0	
	Setting range	0	Two-wire 1		
		1	Two-wire 2		
		2	Three-wire 1		
		3	Three-wire 2		

This parameter defines the external terminal through the inverter to control the operation of four different ways.

0: Two-wire mode 1: This mode is the most commonly used two-line mode. By the terminal DI1, DI2 to determine the motor forward and reverse operation.

Terminal function set as follows:

Terminals	Set point	Description
DI1	1	Forward running (FWD)
DI2	2	Reverse running (REV)

Wherein, DI1, DI2 are multi-function input terminal of DI1 ~ DI10, the level is effective.

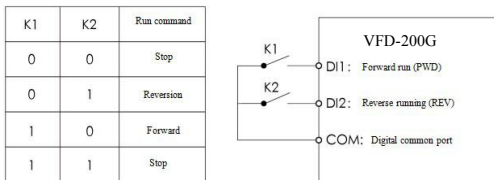

Figure 6-6 Two-line mode 1

1: Two-wire mode 2: Use this mode when DI1 terminal function operation enable terminal and DI2 terminal function to determine the direction.

Terminal function set as follows:

Terminals	Set point	Description
DI1	1	Forward running (FWD)
DI2	2	Reverse running (REV)

Where in, DI1, DI2 are multi-function input terminal of DI1 ~ DI10, the level is effective.

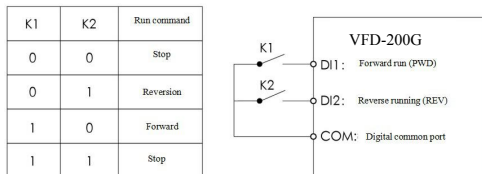

Figure 6-7 Two-line mode 2

Parameter description Specification of VFD-200G high-performance vector

2: Three-wire control mode 1: This mode is enabled terminal DI3, respectively, by direction DI1, DI2 control.

Terminals	Set point	Description
DI1	1	Forward running (FWD)
DI2	2	Reverse running (REV)
DI3	3	Three-wire run control

When there is the need to run, the terminal must first DI 3 closed by the rising edges of the DI1 or DI2 to achieve forward or reverse motor control.

When you need to stop, by disconnecting DI3 terminal shall signal to achieve. Wherein, DI1, DI2, DI3 are multifunctional input terminals of DI1 ~ DI10, DI1, DI2 pulse are effective, DI3 is effective level.

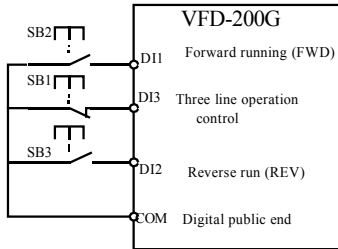

Figure6-8 Three wire control mode 1

Among:

SB1: stop button SB2: Forward button SB3: reverse button

3: Three-line control mode 2: This mode enable terminal to DI 3, run the command given by the DI1, DI2 direction by the state to decide.

Terminal function is set as follows:

Terminals	Set point	Description
DI1	1	Forward running
DI2	2	Reverse running (REV)
DI3	3	Three-wire run control

In the need to run, must first close the DI3 terminal, from the DI1 of the pulse rise along the motor running signal, DI2 state of the motor direction signal.

In the need to stop, it is required to disconnect the DI3 terminal signal to achieve. Among them, DI1, DI2, DI3 for the DI1 ~ DI10 multi function input terminals, DI1 for the pulse effective, DI3, DI2 is effective.

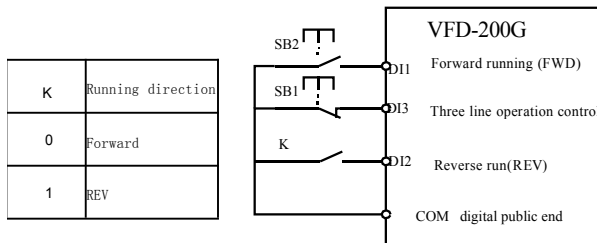

Figure6-9 Three wire control mode 2

Among them: SB1: stop button SB2: run the button

P4-12	Terminal UP / DOWN rate of		Factory default	1.00Hz/s
	Setting	0.01Hz/s~65.535Hz/s		

When setting terminal UP / DOWN adjust set frequency, the frequency rate of change, that is, the amount of change in frequency per second.

When P0-22 (frequency decimal point) is 2, the value is in the range of 0.001Hz / s ~ 65.535Hz / s.

When P0-22 (frequency decimal point) is 1, the value is in the range of 0.01Hz / s ~ 655.35Hz / s.

P4-13	AI curve 1 Minimum Input		Factory default	0.00V
	Setting	0.00V~P4-15		
P4-14	AI curve 1 minimum input corresponding settings		Factory default	0.0%
	Setting	-100.00%~100.0%		
P4-15	AI curve 1 maximum input		Factory default	10.00V
	Setting	P4-13~10.00V		
P4-16	AI curve 1 maximum input corresponding to set		Factory default	100.0%
	Setting	-100.00%~100.0%		
P4-17	AI1 filtering time		Factory default	0.10s
	Setting	0.00s~10.00s		

The above function codes are used to set the analog input voltage setpoint relationship between its representatives.

When the analog input voltage is greater than the set “maximum input” (P4-15), the analog voltage in accordance with the “maximum input” computing; similarly, when the analog input voltage is less than the set “minimum input” (P4-13), according to “AI is below the minimum input setting Select” (P4-34) is set to the minimum input or 0.0% calculated.

When the analog input is current input, 1mA current corresponds to 0.5V.

AI1 input filtering time for setting AI1 software filtering time when the analog easily disturbed site, please increase the filter time so that the analog detection stabilized, but the greater the filtering time of the analog detection slow response times, how to set up a trade-off depending on the application.

In different applications, analog setting 100.0% of the nominal value of the corresponding meanings vary, please refer to the description of each part of the application.

The following illustrates a case where two typical settings:

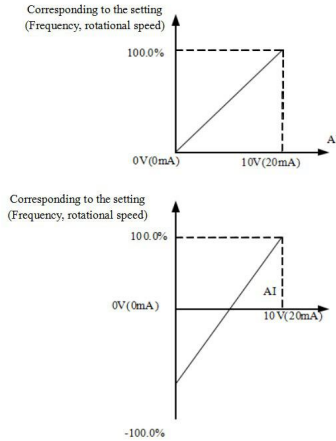

Figure6-10 The corresponding relationship between the simulation and the set amount

P4-18	AI curve 2 minimum input		Factory default	0.00V
	Setting range	0.00V~P4-20		
P4-19	AI curve 2 minimum input corresponding settings		Factory default	0.0%
	Setting range	-100.00%~100.0%		
P4-20	AI curve 2 maximum input		Factory default	10.00V
	Setting range	P4-18~10.00V		
P4-21	AI curve 2 maximum input corresponding to set		Factory default	100.0%
	Setting range	-100.00%~100.0%		
P4-22	AI2 filtering time		Factory default	0.10s
	Setting range	0.00s~10.00s		

Function and use of curve 2, please refer to the description of the curve 1.

P4-23	AI curve 3 minimum input		Factory default	0.00V
	Setting range	0.00s~P4-25		
P4-24	AI curve 3 minimum input corresponding settings		Factory default	0.0%
	Setting range	-100.00%~100.0%		
P4-25	AI curve 3 maximum input		Factory default	10.00V
	Setting range	P4-23~10.00V		
P4-26	AI curve 3 maximum input corresponding to set		Factory default	100.0%
	Setting range	-100.00%~100.0%		
P4-27	AI3 filtering time		Factory default	0.10s
	Setting range	0.00s~10.00s		

Function and use of curve 3, please refer to the description of the curve 1.

P4-28	PULSE minimum input		Factory default	0.00kHz
	Setting range	0.00kHz~P4-30		
P4-29	PULSE minimum input correspondence		Factory default	0.0%
	Setting range	-100.00%~100.0%		
P4-30	PULSE maximum input		Factory default	50.00kHz
	Setting range	P4-28~50.00kHz		
P4-31	PULSE maximum input correspondence		Factory default	100.0%
	Setting range	-100.00%~100.0%		
P4-32	PULSE filtering time		Factory default	0.10s
	Setting range	0.00s~10.00s		

This function code is used to set the relationship DI5 pulse frequency corresponding to the set between.

Pulse frequency inverter can only be entered through DI5 channel. Application and function curve of this group is similar to 1, please refer to Note 1 of the curve.

P4-33	AI curve selection		Factory default	321
	Setting range	Single digit	AI1 curve selection	
		1	Curve 1 (2 points, see P4-13 ~ P4-16)	
		2	Curve 2 (2 points, see P4-18 ~ P4-21)	
		3	Curve 3 (2 points, see P4-23 ~ P4-26)	
		4	Curve 4 (4 points, see A6-00 ~ A6-07)	
		5	Curve 5 (4 points, see A6-08 ~ A6-15)	
		Ten bit	AI2 curve selection (1 ~ 6, the same as above)	
Hundred bit	AI3 curve selection (1 ~ 6, the same as above)			

The function code bits, ten, one hundred are used to select, analog input AI1, AI2, AI3 corresponding setting curve. 3 analog inputs can be selected in any of the five kinds of curve a.

Curve 1, curve 2, curve 3 are 2 point curve, set in P4 group function code, whereas curve 4 and curve 5 are 4 point curve, you need to set the A8 group function codes.

VFD-200G inverter standard unit provides two analog inputs, AI3 must be configured to use multi-function input and output expansion card.

P4-34	AI is below the minimum input setting		Factory default	000
	Setting range	Single digit	AI1 lower than the minimum input settings select	
		0	Corresponding minimum input setting	
		1	0.0%	
		Ten bit	AI2 lower than the minimum input settings selected (0 ~ 1, above)	
Hundred bit	AI3 lower than the minimum input settings selected (0 ~ 1, above)			

The function code is used to set, when the analog input voltage is less than the set "minimum input", the corresponding analog set how to determine.

Parameter description Specification of VFD-200G high-performance vector

The function code unit, ten bit, hundred bit, corresponding to the analog input AI1, AI2, AI3. If this option is 0. When the AI input below the “minimum input”, corresponding to the analog setting function code to determine the curve “minimum input corresponds to a given” (P4-14, P4-19, P4-24).

If this option is 1, then when AE input below the minimum input, the analog corresponding to 0.0%.

P4-35	DI1 delay time		Factory default	0.0s
	Setting	0.0s~3600.0s		
P4-36	DI2 delay time		Factory default	0.0s
	Setting	0.0s~3600.0s		
P4-37	DI3 delay time		Factory default	0.0s
	Setting	0.0s~3600.0s		

When DI terminal for setting status changes, they are changes in the delay time of the inverter. Currently only DI1, DI2, DI3 have set the time delay function.

P4-38	DI terminal effective mode selection 1		Factory default	00000
	Setting range	Single digit	DI1 terminal active set	
		0	Active High	
		1	Active Low	
		Ten bit	DI2 Terminal active set (0-1, supra)	
		Hundred bit	DI3 Terminal active set (0-1, supra)	
		Thousand bit	DI4 Terminal active set (0-1, supra)	
Ten thousand bit	DI5 Terminal active set (0-1, supra)			
P4-39	DI terminal effective mode selection 2		Factory default	00000
	Setting range	Single digit	DI6 terminal active set	
		0	Active High	
		1	Active Low	
		Ten bit	DI7 Terminal active set (0-1, supra)	
		Hundred bit	DI8 Terminal active set (0-1, supra)	
		Thousand bit	DI9 Terminal active set (0-1, supra)	
Ten thousand bit	DI10 Terminal active set (0-1, supra)			

It is used for setting the digital input terminal of the active mode. When choosing high effective, the corresponding S terminal and COM communicated effectively, disconnect invalid. Selected as active low, the corresponding S terminal and COM connectivity invalid, effectively disconnected.

**P5 Group--Output terminals**

VFD-200G series inverter comes standard with a multifunction analog output terminal, a multi-function digital output terminal, a multi-function relay output terminal, an FM terminal (selected as high-speed pulse output terminal, can also choose a set open switch electrode output). As the output terminal can not meet the site with app, you need the optional multi-function input and output expansion card.

Multi-function input and output expansion card output terminals, comprising a multi-function analog output terminal (AO2), 1 multifunction relay output terminal (relay 2), a multi-function digital output terminal (DO2).

P5-00	FM terminal output mode selection		Factory default	0
	Setting range	0	Pulse output (FMP)	
		1	Switching output (FMR)	

FM terminal is a programmable multiplexing terminal can be used as high-speed pulse output terminal (FMP), the switch can also be used as open collector output terminal (FMR).

As the pulse output FMP, the maximum output pulse frequency is 100kHz, FMP-related functions can be found P5-06 instructions.

P5-01	FMRI function selection (open collector output terminal)	Factory default	0
P5-02	Relay output function selection (T / A-T / B-T / C)	Factory default	2
P5-03	Expansion card relay output function selection (P / A-P / B-P / C)	Factory default	0
P5-04	DO1 output function selection (open collector output terminal)	Factory default	1
P5-05	Expansion card DO2 output function selection	Factory default	4

The five function code is used to select the five digital outputs function, where T / A-T / B-T / C and P / A-P / B-P / C, respectively on control board and expansion card relay.

Multi-function output terminal functions are as follows:

Set point	Function	Explanation
0	No output	Output terminal has no function
1	Inverter running	Indicates the drive is in running state, the output frequency (can be zero), ON signal is output.
2	Fault output (downtime)	When the drive fails and downtime, it outputs ON signal.
3	Frequency level detection output FDT1	Please refer to the function code P8-19, P8-20 description.
4	Frequency arrival	Please refer to the function code P8-21 description.
5	Zero speed operation (no output shutdown)	Inverter running and the output frequency is 0, output ON signal. When the drive is shut down, the signal is OFF.
6	Motor overload pre-alarm	Before the motor overload protection, according to the overload pre-alarm threshold value judgment over pre-alarm threshold value output ON signal. Motor overload parameter settings see Function Code P9-00 ~ P9-02.
7	Inverter overload pre-alarm	Before the inverter overload occurs 10s, output ON signal.
8	Set counting value arrival	When the count value reaches the value of PB-08 set, output ON signal.
9	Designated counting value arrival	When the count value reaches the value of PB-09 group, output ON signal. PB reference counting function group Function
10	Length arrival	When detecting the actual length exceeds PB-05 set length, output ON signal.
11	PLC Complete cycle	After simple PLC completes one cycle, the output of a pulse width of 250ms.
12	Total running time arrival	When the accumulated running time exceeds the time set by P8-17, output ON signal.
13	Frequency is defined in	When the set frequency exceeds the upper limit frequency or lower frequency, and output frequency has reached the upper limit frequency or lower frequency, the output ON signal.
14	Torque limiting	Drive under the speed control mode, when the output torque reaches the torque limit, the inverter is in the stall protection status, and ON signal is output.
15	Ready to run	When the inverter main circuit and control circuit power supply has stabilized, and the drive does not detect any fault information, the drive is in an operational state, output ON signal.



Set point	Function	Explanation
16	AI1>AI2	When the value is greater than the analog input AI1 value AI2 input and output ON signal.
17	Upper limit frequency arrival	When the operation frequency reaches the upper limit frequency, output ON signal.
18	The lower limit frequency arrival (not output shutdown)	When the operation frequency reaches the lower limit frequency, output ON signal. Under the standstill signal is OFF.
19	Brown-state output	When the inverter is under voltage state, output ON signal.
20	Communication Preferences	Refer to the communication protocol.
21	Retention	Retention
22	Retention	Retention
23	Zero-speed operation 2 (shutdown also output)	Inverter output frequency is 0, the output ON signal. The signal is also at a standstill is ON.
24	Cumulative power-up time arrival	When the inverter's accumulated power-on time (P7-13) P8-16 exceeds the set time, the output signal is ON.
25	Frequency level detection output FDT2	Please refer to the function code P8-28, P8-29 description.
26	Frequency 1 reaches the output	Please refer to the function code P8-30, P8-31 description.
27	Frequency 2 reaches the output	Please refer to the function code P8-32, P8-33 description.
28	Current 1 reaches the output	Please refer to the function code P8-38, P8-39 description.
29	Current 2 reaches the output	Please refer to the function code P8-40, P8-41 description.
30	The timing to the output	When the timer function Select (P8-42) is valid, the inverter running time after this set timing, output ON signal.
31	AI1 input overrun	When the value is greater than the analog input AI1 P8-46 (AI1 input protection limit) or less than P8-45 (AI1 input protection limit), it outputs ON signal.
32	Carrying out	When the drive is off-load state, output ON signal.
33	Reverse operation	Reverse drive is running, output signal ON
34	Zero current state	Please refer to the function code P8-28, P8-29 description.
35	Module temperature reached	Heat sink temperature of the inverter module (P7-07) to reach the set temperature reaches the value of the module (P8-47), the output signal ON
36	Software current limit	Please refer to the function code P8-36, P8-37 description.
37	The lower limit frequency arrival (also stop output)	When the operation frequency reaches the lower limit frequency, output ON signal. In the stop state of the signal is also ON.
38	Alarm output	When the inverter failure, and the failure to continue processing mode, the inverter alarm output.
39	Motor overtemperature alarm	When the motor temperature reaches P9-58 (motor overheating prediction threshold), the output signal is ON. (motor temperature can be viewed through U0-34)
40	The running time arrival	The inverter starts running longer than the time set by P8-53, output ON signal.

P5-06	FMP output function selection (pulse output terminals)	Factory default	0
P5-07	AO1 output function selection	Factory default	0
P5-08	AO2 output function selection	Factory default	1

FMP terminal pulse frequency output range is 0.01kHz ~ P5-09 (FMP maximum output frequency), P5-09 can be set between 0.01kHz ~ 100.00kHz.

Analog outputs AO1 and AO2 output range is 0V ~ 10V, or 0mA ~ 20mA. Pulse output or analog output range, with the corresponding scaling function relationship in the following table:

Set point	Function	Pulse or analog output corresponding to 0.0% to 100.0% of the function
0	Operating frequency	0 ~ maximum output frequency
1	Set frequency	0 ~ maximum output frequency
2	Output current	0~2 times Motor rated current
3	Output torque	0 to 2 times rated motor torque
4	Output Power	0-2 times of rated power
5	Output voltage	0 to 1.2 times the rated voltage of the inverter
6	Pulse input	0.01kHz~100.00kHz
7	AI1	0V~10V
8	AI2	0V~10V (or 0 ~ 20mA)
9	AI3	0V~10V
10	Length	0 to the maximum set length
11	The count value	0 to the maximum count
12	Communication Preferences	0.0%~100.0%
13	Motor speed	0 ~ maximum output frequency corresponding to the rotational speed
14	Output current	0.0A~1000.0A
15	Output voltage	0.0V~1000.0V

P5-09	FMP maximum output frequency	Factory default	50.00kHz
	Setting range	0.01kHz~100.00kHz	

When FM is selected as a pulse output terminal, the function code is used to select the maximum output pulse frequency value.

P5-10	AO1 zero offset coefficient	Factory default	0.0%
	Setting range	-100.0%~+100.0%	
P5-11	AO1 gain	Factory default	1.00
	Setting range	-10.00~+10.00	
P5-12	Expansion card AO2 zero offset coefficient	Factory default	0.00%
	Setting range	-100.0%~+100.0%	
P5-13	Expansion card AO2 gain	Factory default	1.00
	Setting range	-10.00~+10.00	

Parameter description Specification of VFD-200G high-performance vector

The above function codes are generally used to bias the output amplitude and zero drift correction analog output. It can also be used to customize the desired output curve AO.

If zero offset by “b” represents the gain by k, the actual output by Y, X represents standard output, the actual output is:

$Y=kX+b$ . Wherein, AO1, AO2 zero-bias factor of 100% corresponds to 10V (or 20mA), it refers to the standard output in the absence of bias and gain correction, output 0V ~ 10V (or 0mA ~ 20mA) corresponding to the amount of the analog output.

For example: If the analog output is the operating frequency, at a frequency of 0 output 8V, frequency is the maximum frequency output 3V, the gain should be set to “-0.50” bias should be set to “80%.”

P5-17	FMR output delay time	Factory default	0.0s
	Setting range	0.0s~3600.0s	
P5-18	RELAY1output delay time	Factory default	0.0s
	Setting range	0.0s~3600.0s	
P5-19	RELAY2output delay time	Factory default	0.0s
	Setting range	0.0s~3600.0s	
P5-20	DO1output delay time	Factory default	0.0s
	Setting range	0.0s~3600.0s	
P5-21	DO2output delay time	Factory default	0.0s
	Setting range	0.0s~3600.0s	

Set the output terminals FMR, relay 1, relay 2, DO1 and DO2, from state to produce the actual output delay time change occurs.

P5-22	DO terminal output valid state		Factory default	0
	Setting range	Single digit	FMR active choice	
		0	Positive logic	
		1	Inv	
		Ten bit	RELAY1 Active set (0-1, supra)	
		Hundred bit	RELAY2 Terminal active set (0-1, supra)	
		Thousand bit	DO1 Terminal active set (0-1, supra)	
		Ten thousand bit	DO2 Terminal active set (0-1, supra)	

Define the output terminal of FMR, relay 1, relay 2, DO1 and DO2 output logic.

0: Positive logic, digital output terminal and the corresponding common terminal communicates to the active state, disconnect inactive state;

1: Anti-logic, digital output terminal and the corresponding common terminal communicates to the inactive state, disconnect the active state.

## P6 Group--Start stop control

P6-00	Start mode		Factory default	0
	Setting range	0	Direct start	
		1	Speed tracking restart	
		2	Start pre-excitation (AC induction motor)	

## 0: Direct start

When the DC brake time is set to 0, the inverter starts running from the starting frequency. When the DC brake time is not 0, the DC brake first, and then run from the starting frequency. Suitable for small inertia load when you start the motor may have rotated occasion.

1: Speed tracking restart of the drive motor speed and direction of the judge, and then to track the frequency of the motor start,

Rotating motor smoothly without impact start. Instantaneous power suitable for large inertia load restart. To ensure the performance speed tracking start, you need to accurately set the motor F1 group parameters.

2: Induction pre-excitation start only for asynchronous motors, used before the motor running to first establish a magnetic field. Pre-excitation current, pre-excitation time refer to the function code P6-05, P6-06 instructions.

If the pre-excitation time is set to 0, the drive to cancel pre-excitation process starts from the starting frequency. Pre-excitation time is not 0, the first and then start pre-excitation can improve the dynamic response performance of the motor.

P6-01	Speed tracking mode		Factory default	0
	Setting range	0	Start from stop frequency	
		1	Starting from zero speed	
		2	Start from maximum frequency	

As to complete the process with the shortest time to speed tracking, select the drive motor speed tracking mode:

0: Tracking down from the frequency of the power failure, usually used in this way.

1: Start tracking upwards from zero frequency, for use in case of power failure a long time to start again.

2: Tracking down from the maximum frequency, the general power of the load.

P6-02	Speed tracking speed	Factory default	2
	Setting range	1~100	

When speed tracking restart, select speed tracking speed. Parameter is larger, faster track. But it sets too high may cause tracking results unreliable.

P6-03	Start frequency	Factory default	0
	Setting range	0.00Hz~10.00Hz	
P6-04	Start frequency retention time	Factory default	0
	Setting range	0.0s~100.0s	

As to ensure that the motor torque at start-up, set an appropriate start frequency. In order to establish the full flux motor when starting, we need to start frequency to maintain a certain time.

Start from the lower frequency limit frequency P6-03. But set the target frequency is less than starting frequency, the inverter does not start, it is on standby.

Parameter description Specification of VFD-200G high-performance vector

Reversible switching process, starting frequency holding time does not work. Start frequency holding time is not included in the acceleration time, but is included in the running time of simple PLC.

Example 1:

P0-03=0 Frequency source is digital given

P0-08=2.00Hz Digital set frequency is 2.00Hz

P6-03=5.00Hz Starting frequency is 5.00Hz

P6-04=2.0s Start frequency holding time is 2.0s At this time, the inverter is in the standby state, the inverter output frequency is 0.00Hz.

Example 2:

P0-03=0 Frequency source is digital given

P0-08=10.00Hz Digital set frequency is 10.00Hz

P6-03=5.00Hz Starting frequency is 5.00Hz

P6-04=2.0s Start frequency retention time 2.0s

At this time, the drive accelerates to 5.00Hz, continued to 2.0s, and then accelerated to a given frequency 10.00Hz.

P6-05	DC brake current / and excitation current	Factory default	0%
	Setting range		0%~100%
P6-06	Starting DC braking time / pre-excitation time	Factory default	0.0s
	Setting range		0.0s~100.0s

DC brake is generally used to stop and start the motor running. Pre-excitation is used to make the magnetic field induction motor and then start to establish and improve the response speed.

DC brake is valid only in the start mode is direct start. This time the frequency setting press Start DC braking current DC braking, DC braking time after the start and then start running. If the DC braking time is set to 0, no start directly after DC braking. DC braking current increases, the greater the braking force.

If the startup mode for the asynchronous motor pre-excitation start, the drive set in the pre-press pre-established magnetic field current, after the set pre-magnetizing time before starting to run. If the set pre-magnetizing time is 0, no pre-excitation processes started directly.

DC brake current / pre-excitation current, the percentage relative to the rated drive current.

P6-07	Acceleration and deceleration mode		Factory default	0
	Setting range	0	Linear acceleration and deceleration	
		1	S curve acceleration and deceleration A	
		2	S curve acceleration and deceleration B	

Select the drive frequency change in the start and stop the process of moving way.

0: Linear acceleration and deceleration The output frequency linear increment or decrement. VFD-200G provide four kinds of acceleration and deceleration time. Can be selected via multifunction digital input terminals (P4-00 ~ P4-08).

1: S curve acceleration and deceleration A

Output frequency increases or decreases according to S curve. S curve requires gentle place to start or stop the use, such as elevators, conveyor belt. P6-08 and P6-09 respectively function code defines the time ratio of S curve acceleration and deceleration of the initial segment and the end segment

2: S curve acceleration and deceleration B

In the S-curve acceleration and deceleration B, the motor rated frequency  $f$  is always the inflection point of the S-curve. Shown in Figure 6-12. Generally used for high speed area above the rated frequency requires rapid acceleration and deceleration of the occasion.

When setting frequencies above the rated frequency, acceleration and deceleration time:

$$t = \left( \frac{4}{9} \times \left( \frac{f}{f_b} \right)^2 + \frac{5}{9} \right) \times T$$

Wherein,  $f_s$  is set frequency,  $f_b$  is motor rated frequency,  $T$  is the time the motor nominal frequency  $f_b$

P6-08	S curve start section time ratio	Factory default	30.0%
	Setting range	0.0%~(100.0%-P6-09)	
P6-08	S curve start section time ratio	Factory default	30.0%
	Setting range	0.0%~(100.0%-P6-08)	

P6-08 and P6-09 function codes are defined, S curve acceleration and deceleration A of the initial segment and the end time is the ratio of two function codes to meet:  $P6-08 + P6-09 \leq 100.0\%$ .

Figure 6-11 t1 is the parameter P6-08 defined parameters, output during this time frequency slope increases. t2 is the parameter P6-09 defined time, during this time the output frequency slope changes gradually to zero. During the time between t1 and t2, the output frequency slope is fixed, that this interval be linear acceleration and deceleration.

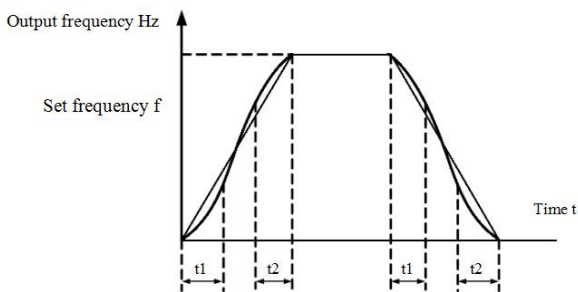

Figure 6-11 S-curve A schematic

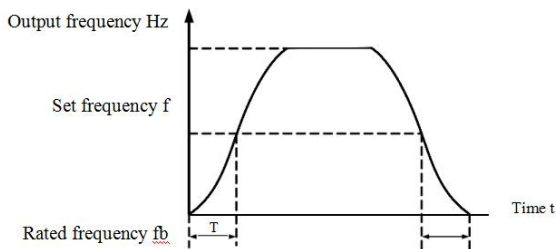

Figure 6-12 S-curve B schematic

P6-10	Stop mode	Factory default	0
	Setting range	0	Deceleration to stop
		1	Free stoppage

0: Deceleration stop When the stop command is valid, the inverter reduces the output frequency according to the deceleration time when the frequency drops to zero downtime.

1: Coast to stop After stop command is valid, the inverter output immediately, and the motor coasts to stop by its mechanical inertia.

Parameter description

Specification of VFD-200G high-performance vector

P6-11	DC injection braking initial frequency	Factory default	0.00Hz
	Setting range	0.00Hz ~ maximum frequency	
P6-12	Halt DC braking waiting time	Factory default	0.0s
	Setting range	0.0s ~ 36.0s	
P6-13	Halt DC braking current	Factory default	0%
	Setting range	0% ~ 100%	
P6-14	Halt DC braking time	Factory default	0.0s
	Setting range	0.0s ~ 36.0s	

DC injection braking Starting frequency: deceleration stop process, when the operating frequency to reduce the frequency to start DC braking process.

DC braking waiting time: the operating frequency is reduced to DC braking starting frequency, the inverter will stop output for some time before starting DC braking process. At high speed to prevent the start of DC braking can cause over-current fault.

DC braking current: DC braking means the output current, the relative percentage of the motor rated current. The higher this value, the DC brake effect, but the greater the heat the motor and the inverter.

DC braking time: DC braking holding time. This value is 0 DC braking process is canceled. DC injection braking process schematic diagram shown in Figure 6-13.

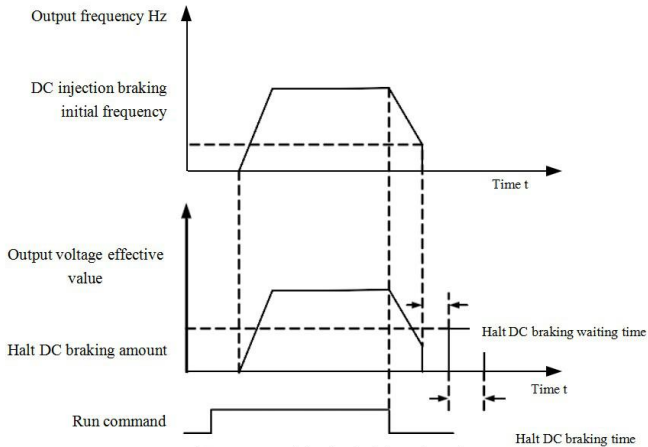

Figure 6-13 DC injection braking schematic

P6-15	Brake usage	Factory default	100%
	Setting range	0%~100%	

Only the built-in braking unit is valid.

Duty cycle, brake usage rate is used to adjust the movable unit, the high duty cycle operation of the braking unit, the braking effect is strong, but the inverter braking bus voltage fluctuations.

## P7 Group--Keyboard and Display

P7-01	JOG key function selection	Factory default	0
	Setting range	0	JOG key is invalid
		1	Operation panel command channel and remote command channel (terminal command channel or command channel)
		2	Reversing switch
		3	Forward jog
		4	Reverse jog

JOG key for the multi-function keys, you can set the JOG key functions via the function code. In the shutdown and can be run through the key switch.

0: This key has no function.

1: Keyboard commands and remote operation switch. Means an order to switch the source, namely the current command source and keyboard control (local operation) switch. If the current command source is keypad control, this key function is disabled.

2: Reversible switching direction switching by frequency command JOG key. This feature is only command source operation panel command channel is active.

3: Forward jog forward rotation Jog (FJOG) JOG key keyboard.

4: Reverse jog achieve reverse jog (RJOG) JOG key keyboard.

P7-02	STOP / RESET key function	Factory default	1
	Setting range	0	Only in keyboard mode, STOP / RES key stop function effectively
		1	In any operating mode, STOP / RES key stop function is valid



		LED display running parameters 1	Factory default	1F
P7-03	Setting range	0000~ FFFF		
			<p>If a parameter needs to be displayed during the running, set the corresponding bit to 1, and set P7-03 to the hexadecimal equivalent of this binary number.</p>	
P7-04	Setting range	0000~ FFFF		0
			<p>If a parameter needs to be displayed during the running, set the corresponding bit to 1, and set P7-04 to the hexadecimal equivalent of this binary number.</p>	

These two parameters are used to set the parameters that can be viewed when the AC drive is in the running state. You can view a maximum of 32 running state parameters that are displayed from the lowest bit of P7-03.

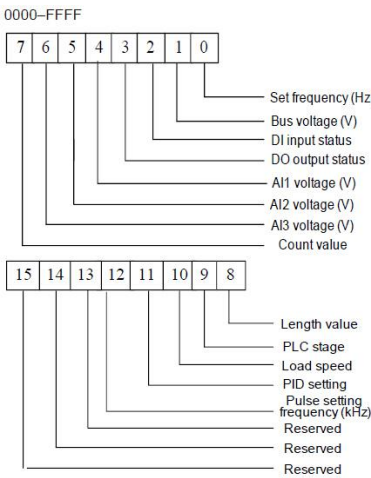
<b>P7-05</b>	LED display stop parameters		Factory default	0
	Setting range	0000 ~ FFFF	 <p>If a parameter needs to be displayed during the running, set the corresponding bit to 1, and set F7-05 to the hexadecimal equivalent of this binary number.</p>	

P7-06	Load speed display coefficient	Factory default	1.0000
	Setting range	0.0001~6.5000	

When you need to display the load speed, this parameter, adjusting the correspondence between the output frequency and load speed. Correspondence between specific reference P7-12 description.

P7-07	Heat sink temperature of the inverter module	Factory default	0
	Setting range	0.0°C~100.0°C	

Display inverter module IGBT temperature.

Different models of inverter module IGBT overtemperature protection value is different.

P7-08	Rectifier heatsink temperature	Factory default	0
	Setting range	0.0°C~100.0°C	

Temperature display rectifier.

Different models of the rectifier overtemperature protection value is different.

P7-09	Total running time	Factory default	0h
	Setting range	0h~65535h	

Displays the accumulated run time of the inverter. When running time reaches the set running time P8-17, the inverter multi-function digital output (12) outputs ON signal.

Parameter description

Specification of VFD-200G high-performance vector

P7-10	Product No.		Factory default	
	Setting range		Inverter product number	
P7-11	Software version number		Factory default	
	Setting range		Control panel software version number.	
P7-12	Load speed display decimal digits		Factory default	0
	Setting range	0	0 decimal places	
		1	1 decimal places	
		2	2 decimal places	
		3	3 decimal places	

Load speed setting for the decimal display. The following example illustrates the calculation of load speed:

If the load speed display coefficient 2.000 P7-06, P7-12 load speed to 2 decimal places (two decimal places), when the inverter operating frequency 40.00Hz, the load speed:  $40.00 * 2.000 = 80.00$  (2 decimal places display)

If the drive is shut down, the load speed display setting frequency corresponding to the speed, that is, "to set the load speed." To set the frequency 50.00Hz, for example, the stop state load speed:  $50.00 * 2.000 = 100.00$  (two decimal display)

P7-13	Cumulative power-up time		Factory default	0h
	Setting range		0h~65535h	

Cumulative power-time display from the factory started the drive.

This time reaches the set power-up time (P8-17), the inverter multi-function digital output (24) outputs ON signal.

P7-14	The total power consumption		Factory default	-
	Setting range		0 to 65535 KWh	

So far show the total power consumption of the drive.

P8 Group--Auxiliary function

P8-00	Jog frequency		Factory default	2.00Hz
	Setting range		0.00Hz ~ maximum frequency	
P8-01	Jog acceleration time		Factory default	20.0s
	Setting range		0.00s~6500.0s	
P8-02	Jog Deceleration time		Factory default	20.0s
	Setting range		0.00s~6500.0s	

When you define the drive jog a given frequency and the deceleration time.

Jog running, start fixed direct start-up mode (P6-00 = 0), stop mode is fixed to decelerate stop (P6-10 = 0).

P8-03	Acceleration time 2		Factory default	20.0s
	Setting range		0.0s~6500.0s	

P8-04	Deceleration time 2		Factory default	20.0s
	Setting range		0.0s~6500.0s	

P8-05	Acceleration time 3	Factory default	20.0s
	Setting range	0.0s~6500.0s	
P8-06	Deceleration time 3	Factory default	20.0s
	Setting range	0.0s~6500.0s	
P8-07	Acceleration time 4	Factory default	20.0s
	Setting range	0.0s~6500.0s	
P8-08	Deceleration time 4	Factory default	20.0s
	Setting range	0.0s~6500.0s	

VFD-200G provide 4 group of acceleration and deceleration time, respectively P0-17 / P0-18 and said 3 group of acceleration and deceleration time.

4 group define exactly deceleration time, refer to the P0-17 and P0-18 instructions. Through different combinations of multifunction digital input terminal DI, you can switch between 4 group of acceleration and deceleration time, please refer to the specific use function code P4-01 ~ P4-05 of instructions.

P8-09	Skip frequency 1	Factory default	0.00Hz
	Setting range	0.00Hz ~ maximum frequency	
P8-10	Skip frequency 2	Factory default	0.00Hz
	Setting range	0.00Hz ~ maximum frequency	
P8-11	Jump frequency range	Factory default	0.00Hz
	Setting range	0.00Hz ~ maximum frequency	

When the jump frequency range within the set frequency, the actual running frequency will run at a frequency from the set frequency jump closer. By setting the frequency hopping allows the drive to avoid the mechanical resonance point of load. VFD-200G can set two skip frequencies, when the two skip frequencies are set to 0, the jump frequency function is canceled. Principle jump frequency and the amplitude of frequency hopping schematic, refer to Figure 6-14.

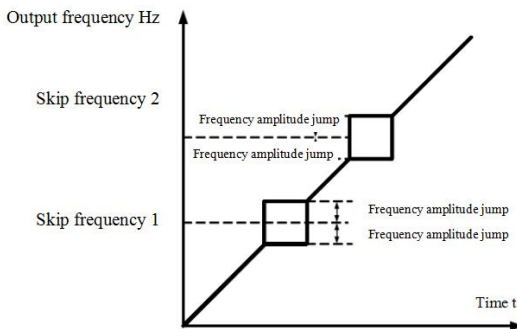

Figure 6-14 Skip frequency schematic

P8-12	Reversible dead time	Factory default	0.0s
	Setting range	0.00s~3000.0s	

Set the inverter reversing the transition process, the output of 0Hz at the time of transition, shown in Figure 6-15:

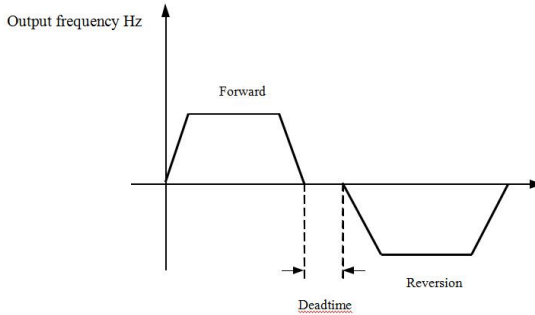

Figure 6-15 Reversible schematic dead time

P8-13	Inversion of Control Enable	Factory default	0
	Setting range	0	Allow
		1	Ban

Set up the drive via the parameter is allowed to run in the inverted state, in the case of motor reversal is not allowed to set P8-13 = 1.

P8-14	Set frequency is lower than the lower limit frequency operation mode	Factory default	0
	Setting range	0	Operation in lower limit frequency
		1	Shutdown
		2	Running at zero speed

When the set frequency is lower than minimum frequency, the operating status of the inverter can be selected using this parameter. VFD-200G offers three operating modes to meet various application requirements.

P8-15	Droop control	Factory default	0.00Hz
	Setting range	0.00Hz~10.00Hz	

This feature is typically used for load distribution of multiple motor drive with a load.

Droop control means that as the load increases, so that the inverter output frequency decreases, so more than one motor drive the same load, the load of the motor output frequency drops more, thereby reducing the load of the motor to achieve multiple motors load evenly.

This parameter refers to the inverter rated output load, the output value of the frequency drops.

P8-16	Set the accumulated power-on time	Factory default	0h
	Setting range	0h~65000h	

When the accumulated power-on time (P7-13) P8-16 reach the set power-up time, the inverter multi-function digital output DO ON signal. The following examples illustrate the application:

Example: Combining virtual DIDO function, to achieve the set power-up time after reaching 100 hours, the inverter fault alarm output. Program:

Virtual DI1 terminal function set to user-defined fault 1: A1-00 = 44;

DI1 virtual terminal active, is set to come from virtual DO1: A105 = 0000; virtual DO1 function, set the power-on time of arrival: A1-11 = 24; set the power accumulated 100 hours of arrival: P8-16 = 100.

When the cumulative power-up time of 100 hours, and the inverter fault output Err24.

P8-17	Set the accumulated run time	Factory default	0h
	Setting range	0h~65000h	

It is used to set the running time of the inverter.

When the total running time (P7-09) reaches this setup running time, the inverter multi-function digital output DO ON signal.

P8-18	Start protection selection		Factory default	0
	Setting range	0	Does not protect	
		1	Protection	

This parameter is related to the security function of the inverter.

If this parameter is set to 1 if the time run on electric drive command is active (for example, a terminal run command before power is in a closed state), the inverter does not respond to the Run command, you must first run the command once removed, run the command again after the effective drive only response.

In addition, if the parameter is set to 1, if the inverter fault reset time run command, the inverter will not run in response to a command, you must first run the command to remove the running protection status.

Setting this parameter to 1 can be prevented in the knowledge, that occur at power or fault reset, the motor operates in response to commands and cause danger.

P8-19	Frequency detection value (FDT1)	Factory default	50.00Hz
	Setting range	0.00Hz ~ maximum frequency	
P8-20	Frequency detection hysteresis value (FDT1)	Factory default	5.0%
	Setting range	0.0% ~ 100.0% (FDT1 level)	

When the operating frequency higher than the frequency detection value, the inverter output DO multifunction output ON signal, and the frequency is lower than the detection value after a certain frequency, output ON DO signal is canceled.

Said parameter value is set for detecting the output frequency, output value and hysteresis action removed. Wherein P8-20 lag frequency percentage frequency detection value P8-19 respect. Figure 6-16 is a schematic diagram FDT functionality.

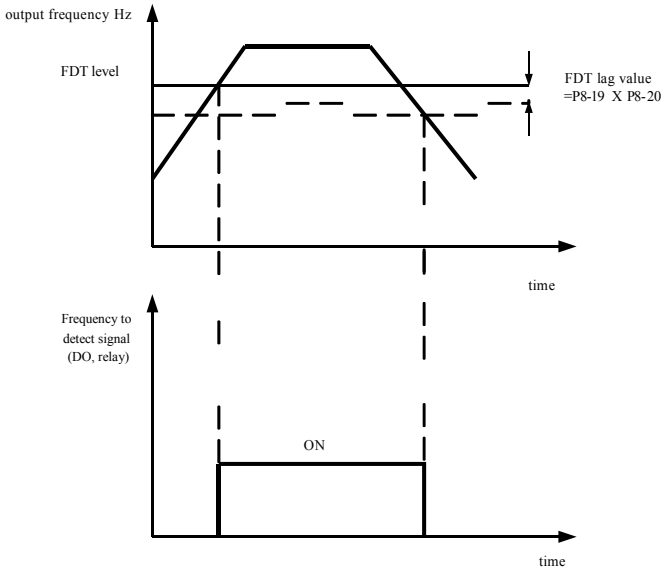

Figure 6-16 FDT level schematic

P8-21	Frequency arrival detection width	Factory default	0.0%
	Setting range	0.0% to 100% (maximum frequency)	

Operating frequency of the inverter, and is in the target frequency range, the inverter output multifunction DO ON signal.

This parameter is used to set the frequency arrival detection range, the parameter is a percentage of the maximum frequency. Figure 6-17 is a schematic diagram of a frequency to reach.

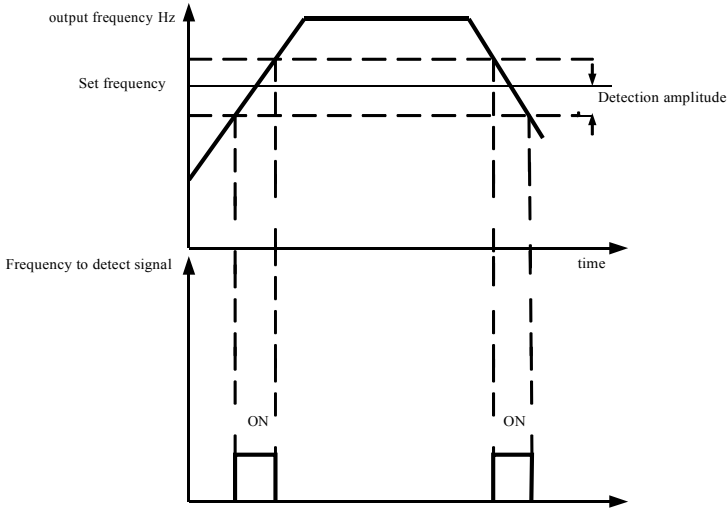

Figure 6-17 Frequency arriving detection amplitude schematic

P8-22	Acceleration and deceleration process Jump frequency whether it is valid	Factory default	0
	Setting range	0: Invalid 1: Valid	

The function code is used to set, during acceleration or deceleration, the jumping frequency is valid. Is set to be valid when running at a frequency hopping frequency range, the actual operating frequency will jump frequency setting to skip the border. Figure 6-18 acceleration and deceleration process schematic jump frequency is effective.

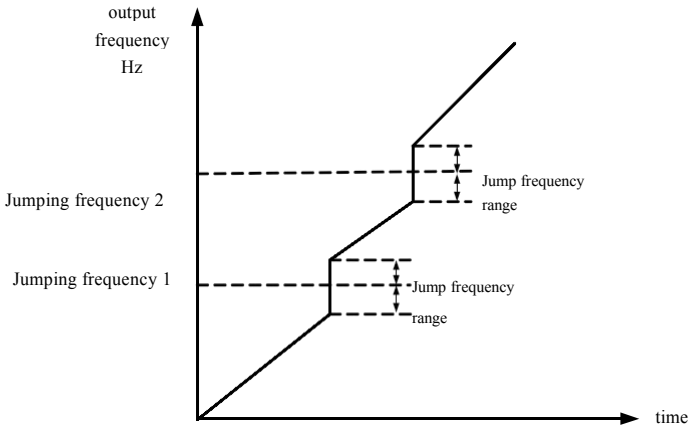

Figure 6-18 acceleration and deceleration process Jump frequency effective schematic



P8-25	Acceleration time Acceleration time 1 and 2 switching frequency points	Factory default	0.00Hz
	Setting range	0.00Hz ~ maximum frequency	
P8-26	Deceleration time 2 and deceleration time 1 switching frequency point	Factory default	0
	Setting range	0.00Hz to maximum frequency	

This function is selected as the motor in the motor 1, and not switched by DI terminal when selecting acceleration and deceleration time is valid. For the inverter is running, but not according to the operating frequency range to choose different acceleration and deceleration times by DI terminals.

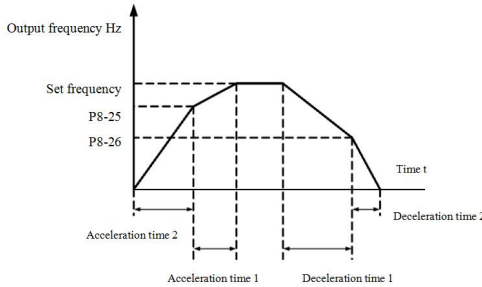

Figure 6-19 acceleration and deceleration time switch schematic

Figure 6-19 is a schematic view of acceleration and deceleration time switching. During acceleration, if the operating frequency is less than P8-25 selects the acceleration time 2; if the operating frequency is greater than the acceleration time 1 Select P8-25.

During deceleration, if the operating frequency is greater than P8-26 Deceleration Time 1 is selected, if the operating frequency is less than the deceleration time 2 Select P8-26.

P8-27	Terminal jog priority	Factory default	0
	Setting range	0: Invalid 1: Valid	

This parameter is used to set whether the terminal jogging function has the highest priority.

When the terminal jogging priority effective, if the terminal point move command occurs during operation, the drive is switched to the terminal jogging running.

P8-28	Frequency detection value (FDT2)	Factory default	50.00Hz
	Setting range	0.00Hz ~ maximum frequency	
P8-29	Frequency detection hysteresis value (FDT2)	Factory default	5.0%
	Setting range	0.0% ~ 100.0% (FDT2 level)	

The frequency detection function FDT1 the same functions FDT1 refer to the instructions that function code P8-19, P8-20 description.

P8-30	Any reached frequency detection value 1	Factory default	50.00Hz
	Setting range	0.00Hz ~ maximum frequency	

P8-31	Any reached frequency detection range 1	Factory default	0.0%
	Setting range	0.0% to 100.0% (maximum frequency)	
P8-30	Any reached frequency detection value 2	Factory default	50.00Hz
	Setting range	0.00Hz ~ maximum frequency	
P8-31	Any reached frequency detection range 2	Factory default	0.0%
	Setting range	0.0% to 100.0% (maximum frequency)	

When the output frequency of the inverter, when arriving at any frequency detection value detected positive and negative amplitude range, multi-DO output ON signal.

VFD-200G arrival frequency detection provides two sets of arbitrary parameters were set frequency value and frequency detection range. 6-20 schematic diagram for the function.

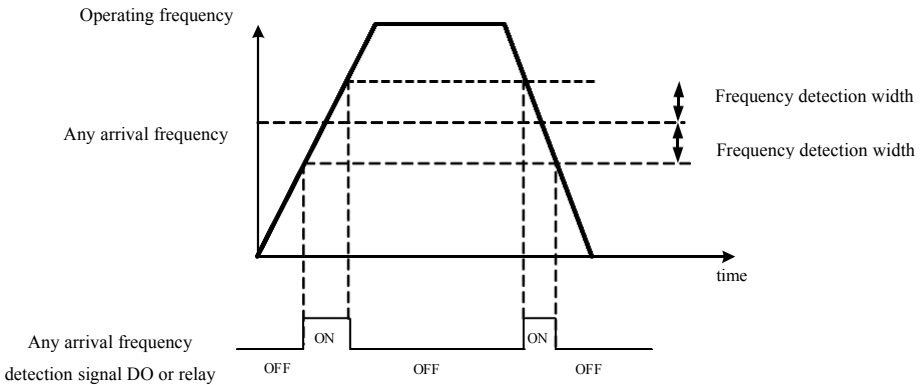

Figure 6-20 arbitrary frequency detection arrival schematic

P8-34	Zero-current detection level	Factory default	5.0%
	Setting range	0.0%~300.0% (motor rated current)	
P8-35	Zero-current detection delay time	Factory default	0.10s
	Setting range	0.00s~600.00s	

When the inverter output current is less than or equal to zero current detection level and lasts longer than the zero current detection delay time, the inverter output multifunction DO ON signal. Figure 6-21 zero current detection Fig.

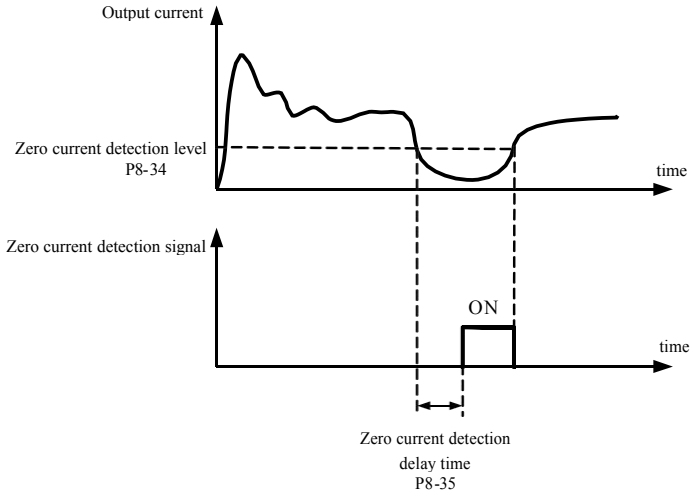

Figure 6-21 Zero current detection schematic

P8-36	Output current limit value	Factory default	200.0%
	Setting range	0.0% (not detected) 0.1%~300.0% (motor rated current)	
P8-37	Output current limit detection delay time	Factory default	0.00s
	Setting range	0.00s~600.00s	

When the inverter output current is greater than or overrun detection point, and lasts longer than the software overcurrent detection delay time, the inverter output multifunction DO ON signal Figure 6-22 output current limit function schematic.

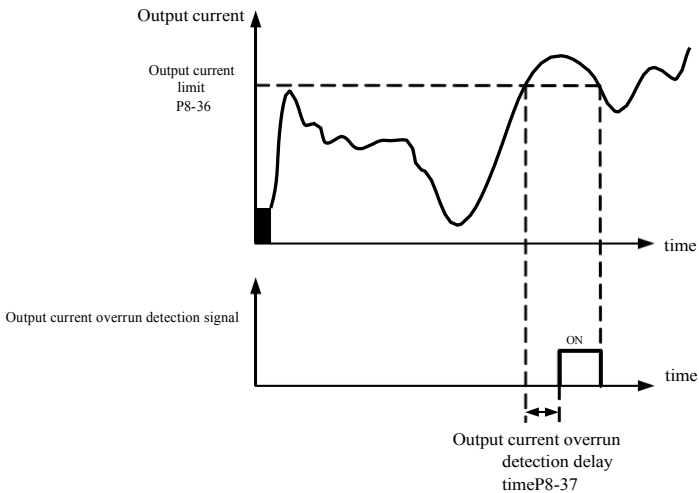

Figure 6-22 Output current limit detection schematic

P8-38	Any arrival current 1	Factory default	100.0%
	Setting range	0.0%~300.0% (motor rated current)	
P8-39	Any arrival current width 1	Factory default	0.0%
	Setting range	0.0%~300.0% (motor rated current)	
P8-40	Any arrival current 2	Factory default	100.0%
	Setting range	0.0%~300.0% (motor rated current)	
P8-41	Any arrival current width 2	Factory default	0.0%
	Setting range	0.0%~300.0% (motor rated current)	

When the output current of the inverter, setting the current reach any positive or negative detection width, the inverter output multifunction DO ON signal.

VFD-200G provides two sets of current and any arrival detection width parameter, a functional schematic diagram in Figure 6-23.

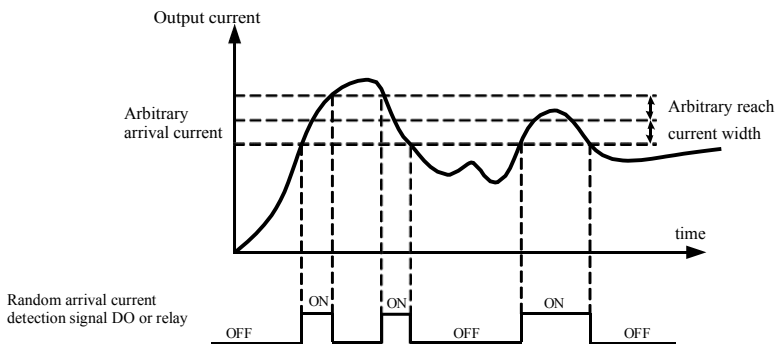

Figure 6-23 Schematic diagram of any arrival current detection

P8-42	Timing function selection	Factory default	0
	Setting range	0	Invalid
		1	Valid
P8-43	Timed Run time selection	Factory default	0
	Setting range	0	Setting P8-44
		1	AI1
		2	AI2
		3	AI3
Analog Input Range 100% correspond to P8-44			
P8-44	Timed Run Time	Factory default	0.0Min
	Setting range	0.0Min~6500.0Min	

The set of parameters used to complete the drive timing running function.

When P8-42 timing function selection is valid, the inverter starts the beginning of time, after reaching set the timer run time, the inverter automatically shut down, while multi-function DO output ON signal.

When the drive each time you start, you start counting from 0, time remaining operating time by U0-20 view. Regular operation time set by P8-43, P8-44, the time in minutes.

P8-45	All input voltage protection lower limit values	Factory default	3.10V
	Setting range	0.00V~P8-46	
P8-46	All input voltage protection upper limit values	Factory default	6.80V
	Setting range	P8-45~10.00V	

When the value is greater than the analog input A11 P8-46, P8-47 less than or A11 input, the output of the inverter multifunction DO “A11 input overrun” ON signal for indicating A11 input voltage is within a set range.

P8-47	Module temperature reached	Factory default	75℃
	Setting range	0.00V~P8-46	

The inverter heat sink temperature reaches this temperature, the inverter output multifunction DO “module temperature reaches the” ON signal.

P8-48	Cooling fan control	Factory default	0
	Setting range	0: fan operates when running 1: The fan has been running	

It is used to select the cooling fan operation mode selection 0. Inverter fan running in the running state, stop state if the heat sink temperature is higher than 40 degrees then the fan is running, stop state radiator fan is not lower than 40 degrees operation.

Select 1, the fan after power has been running.

P8-49	Wake frequency	Factory default	0.00Hz
	Setting range	Sleep frequency (P8-51) ~ maximum frequency (P0-10)	
P8-50	Wake-up delay time	Factory default	0.0s
	Setting range	0.0s~6500.0s	
P8-51	Sleep frequency	Factory default	0.00Hz
	Setting range	0.00Hz ~ wake-frequency (P8-49)	
P8-52	Sleep latency	Factory default	0.0s
	Setting range	0.0s~6500.0s	

This group used to implement the water supply system in sleep and wake function.

The inverter is running, when the set frequency is less than or equal P8-51 Sleep frequency, P8-52 after the delay time, the drive goes to sleep, and automatically shut down. If the drive is in a dormant state, and the current run command, when the set frequency greater than or equal frequency wake P8-49, P8-50 after a time delay, the drive started.

In general, set the wake-sleep frequency greater than or equal frequency. Sleep and wake-up frequency setting frequency was 0.00Hz, then sleep and wake up function is invalid.

When hibernation is enabled, if the frequency source using PID, the PID sleep state whether operations by PA-28 affect the function code, in which case you must select the shutdown operation when PID (PA-28 = 1).

P8-53	The running time of arrival	Factory default	0.0Min
	Setting range	0.0Min~6500.0Min	

When this started running time arrival this time, the inverter multi-function digital output DO “The running time arrival” ON signal.

## P9 Group--Fault and Protection

P9-00	Motor overload protection selection	Factory default	1
	Setting range	0 Ban 1 Allow	
P9-01	Motor overload protection gain	Factory default	1.00
	Setting range	0.20~w10.00	

P9-00 = 0: No motor overload protection function may present a risk of damage to the motor overheating, the proposed increase thermal relay between the inverter and the motor;

P9-00 = 1: the frequency converter according to the motor overload inverse time curve to determine whether the motor is overloaded. Motor overload inverse time curve:  $220\% \times (P9-01) \times$  motor rated current for 1 minute, the alarm of motor overload fault;  $150\% \times (P9-01) \times$  rated motor current, the motor 60 minutes the alarm overload.

User according to the actual motor overload, set the correct value of P9-01, this parameter is set too easily lead to motor overheating and the risk of damage to the inverter not alarm!

P9-02	Motor overload warning coefficient	Factory default	80%
	Setting range	50%~100%	

This function is used before the motor overload fault protection, through DO to the control system a warning signal. The warning coefficient is used to determine, before the motor overload early warning extent. The higher the value the smaller the amount of advance warning.

When the inverter output current cumulative amount greater than overload inverse curves and P9-02 product, multifunction drive DO digital output “motor overload pre-alarm” ON signal.

P9-03	Oversvoltage stall gain	Factory default	0
	Setting range	0 (no oversvoltage stall)~100	
P9-04	Oversvoltage stall protection voltage	Factory default	130%
	Setting range	120%~150% (three-phase)	

During the deceleration, when the DC bus voltage exceeds the oversvoltage stall protection voltage, the inverter stop deceleration is maintained at the current operating frequency, voltage drops until the bus continues to decelerate.

Oversvoltage stall gain for adjusting during deceleration, the drive capacity in suppressing the pressure. The bigger the value, the stronger the ability to suppress the oversvoltage. Without oversvoltage occurs, the gain is set as small as possible.

For small inertia load, over-voltage stall gain should be small, otherwise the system dynamic response slow. For large inertia loads, this value should be large, otherwise the suppression ineffective, oversvoltage fault may occur.

Oversvoltage stall when the gain is set to 0, the cancellation of oversvoltage stall function.

P9-05	Over current stall gain	Factory default	20
	Setting range	0~100	
P9-06	Overcurrent stall protection current	Factory default	150%
	Setting range	100%~200%	

In the inverter deceleration process, when the output current exceeds the overcurrent stall protection current, the inverter stops deceleration process is maintained at the current operating frequency, output current drops and then continue to be deceleration.

Over-flow speed gain is used to adjust the acceleration and deceleration process, the drive capacity in suppressing the flow. The bigger the value, the stronger the capacity is. In the stream without happened next, the gain is set as small as possible.

For small inertia load, over-current stall gain should be small, otherwise the system dynamic response slow. For large inertia loads, this value should be large, otherwise the suppression ineffective, overcurrent fault may occur.

0 when the stall gain is set to cancel the stall function.

P9-07	Power-to-ground short circuit protection	Factory default	1
	Setting range	0	Invalid
		1	Valid

Select the inverter at power, detecting whether the motor is shorted to ground.

If this function is active, the UVW side of the inverter after power-output voltage will be a period of time.

P9-09	Fault auto reset times	Factory default	0
	Setting range	0~20	

When the inverter selects fault auto reset, used to set the number of auto reset. More than this number of times the drive remains a fault condition.

P9-10	During the auto-reset fault DO action selection	Factory default	1
	Setting range	0: no action 1: Action	

If the drive is set up automatic fault reset function, then during automatic fault reset, fault DO whether action can be set by P9-10.

P9-11	Fault automatic reset interval	Factory default	1.0s
	Setting range	0.1s~100.0s	

Since the inverter fault alarm, automatic fault reset time to wait between.

P9-12	Input phase loss protection selection	Factory default	1
	Setting range	0: ban 1: allow	

Select whether the input phase loss protection.

VFD-200G inverter 18.5kW G-type machines and more power, have input phase protection, 18.5kW P-type machine less power. Regardless of P9-12 is set to 0 or 1 have no input phase loss protection.

P9-13	Output phase loss protection selection	Factory default	1
	Setting range		0: ban 1: allow

Choose whether to output phase loss protection.

P9-14	The first type of failure	0~99
P9-15	The second type of failure	
P9-16	The second (last) fault type	

Recording drive last three fault types, 0 is no fault. On possible causes and solutions for each fault code, please refer to Chapter 8 for instructions.

P9-17	The second fault frequency	Last frequency fault																				
P9-18	The second fault current	Last fault current																				
P9-19	The second bus voltage failure	Last bus voltage fault																				
P9-20	Input terminal status at fault second	<p>Last fault state when the digital input terminals, the order is:</p> <table border="1" style="margin-left: auto; margin-right: auto;"> <tr> <td>BIT9</td><td>BIT8</td><td>BIT7</td><td>BIT6</td><td>BIT5</td><td>BIT4</td><td>BIT3</td><td>BIT2</td><td>BIT1</td><td>BIT0</td> </tr> <tr> <td>D10</td><td>D19</td><td>D18</td><td>D17</td><td>D16</td><td>D15</td><td>D14</td><td>D13</td><td>D12</td><td>D11</td> </tr> </table> <p>When the input terminals of the corresponding two of N is set to 1, OFF or 0, the status of all DI converted to decimal display.</p>	BIT9	BIT8	BIT7	BIT6	BIT5	BIT4	BIT3	BIT2	BIT1	BIT0	D10	D19	D18	D17	D16	D15	D14	D13	D12	D11
BIT9	BIT8	BIT7	BIT6	BIT5	BIT4	BIT3	BIT2	BIT1	BIT0													
D10	D19	D18	D17	D16	D15	D14	D13	D12	D11													
P9-21	The second fault output terminal	<p>Last fault state when the digital input terminals, the order is:</p> <table border="1" style="margin-left: auto; margin-right: auto;"> <tr> <td>BIT4</td><td>BIT3</td><td>BIT2</td><td>BIT1</td><td>BIT0</td> </tr> <tr> <td>DO2</td><td>DO1</td><td>REL2</td><td>REL1</td><td>FMP</td> </tr> </table> <p>When the input terminals of the corresponding two of N is set to 1, OFF or 0, the status of all DI converted to decimal display.</p>	BIT4	BIT3	BIT2	BIT1	BIT0	DO2	DO1	REL2	REL1	FMP										
BIT4	BIT3	BIT2	BIT1	BIT0																		
DO2	DO1	REL2	REL1	FMP																		
P9-22	The second fault drive status	Retention																				
P9-23	The second fault power-on time	The second power-up time of the last fault																				
P9-24	The second fault running time	The running time of the last fault																				
P9-27	The second fault frequency	The same with P9-17~P9-24																				
P9-28	The second fault current																					
P9-29	The second bus voltage failure																					
P9-30	Input terminal status at fault second																					
P9-31	The second fault output terminal																					
P9-32	The second fault drive status																					
P9-33	The second fault power-on time																					
P9-34	The second fault running time																					



P9-37	The first fault drive status	The same with P9-17~P9-24
P9-38	The first fault power-on time	
P9-39	The first fault running time	
P9-40	The first fault frequency	
P9-41	The first fault current	
P9-42	The first bus voltage failure	
P9-43	Input terminal status at fault first	
P9-44	The first fault output terminal	

P9-47	Fault protection action selection 1	Factory default	00000	
	Setting range	Single digit	Motor overload (Err11)	
		0	Freewheel	
		1	Halt according to halt mode	
		2	Continue to run	
		Ten bit	Input phase (Err12) (same unit)	
		Hundred bit	Output Phase (Err13) (same unit)	
		Thousand bit	External fault (Err15) (same unit)	
Ten thousand bit		Communication Abnormal (Err16) (same unit)		
P9-48	Fault protection action selection 2	Factory default	00000	
	Setting range	Single digit	Encoder failure (Err20)	
		0	Freewheel	
		1	Switch to VF, press the stop mode	
		2	Switch to VF, continues to run	
		Ten bit	Abnormal function code reader (Err21)	
		0	Freewheel	
		1	Halt according to halt mode	
		Hundred bit	Retention	
		Thousand bit	Motor overheating (Err 25) (same with P9-47 unit)	
Ten thousand bit		Running time arrival (Err26) (same with P9-47 unit)		
P9-49	Fault protection action selection 3	Factory default	00000	
	Setting range	Single digit	User-defined fault 1 (Err27) (same with P9-47 unit)	
		Ten bit	User-defined fault 2 (Err28) (same with P9-47 unit)	
		Hundred bit	Power-on time is reached (Err29) (same with P9-47 unit)	
		Thousand bit	Carrying out (Err30)	
		0	Freewheel	
		1	Halt according to halt mode	
		2	Decelerated to 7% of the rated motor frequency continues to run, can not afford to load automatically returns to the set frequency operation	
Ten thousand bit		Runtime PID feedback loss (Err31) (same with P9-47 unit)		

P9-50	Fault protection action selection 4		Factory	00000
	Setting range	Single digit	Excessive speed deviation (Err42) (with P9-47 bits)	
		Ten bit	Super speed motor (Err43) (with P9-47 bits)	
		Hundred bit	The initial position error (Err51) (with P9-47 bits)	
		Thousand bit	the initial position error (Err52) (with P9-47 bits)	
	Ten thousand bit	Retention		

When you select “free parking”, inverter displays Err \*\*, and directly down.

When selecting the “stop in stopping mode”: The inverter displays A \*\*, press the stop mode, the display Err \*\* after the shutdown.

When you select the “continue”: drive continues to operate and display A \*\*, the operating frequency is set by the P9-54.

P9-54	Continue to run frequency selection		Factory default	0
	Setting range	0	In the current operating frequency operation	
		1	Operation in set frequency	
		2	Operation in upper limit frequency	
		3	Operation in lower limit frequency	
	4	Alternate abnormal frequency operation		
P9-55	Abnormal alternative frequencies		Factory default	100.0%
	Setting range		60.0%~100.0%	

When the inverter is running a fault, and the fault handling is set to continue, the drive display A \*\*, and operates at a frequency determined to P9-54.

When you select an alternate abnormal frequency operation, the value set by P9-55 is a percentage of the maximum frequency.

P9-56	Motor temperature sensor type		Factory default	0
	Setting range	0	No Temperature Sensor	
		1	PT100	
		2	PT1000	
P9-57	Motor overheating protection		Factory default	110℃
	Setting range		0℃~200℃	
F9-58	Motor overheating prediction alert		Factory default	90℃
	Setting range		0℃~200℃	

Temperature signal motor temperature sensor needs to be connected to the multifunction input and output expansion card, which is optional. Analog expansion card input AI3, can be used as motor temperature sensor input, the motor temperature sensor signal then AI3, PGND terminal.

VFD-200G AI3 analog inputs of PT100 and PT1000 supports two kinds of motor temperature sensor, the sensor must be set to the correct type of use. Motor temperature values are displayed in the U0-34.

When the motor temperature exceeds the motor overheating protection threshold P9-57, inverter fault alarm, fault protection action and processed according to the selected mode.

When the motor temperature exceeds the threshold P9-58 motor overheating forecast, the drive multifunction digital output DO Motor overtemperature pre-alarm ON signal.

P9-59	Instantaneous stop action selection		Factory default	0
	Setting range	0	Invalid	
		1	Slow down	
		2	Slowdown stop	
P9-60	Momentary power failure deceleration frequency switching point	Factory default	0.0%	
	Setting range	0.0%~100.0%		
P9-61	Instantaneous power voltage recovery judgment time	Factory default	0.50s	
	Setting range	0.00s~100.00s		
P9-62	Instantaneous stop non-stop action judgment voltage	Factory default	80.0%	
	Setting range	60.0%~100.0% (standard bus voltage)		

This feature means that in an instant power failure or a sudden drop in voltage, the inverter by reducing the output speed, back to reduce the load energy compensation inverter DC bus voltage to maintain the drive continues to run.

If P9-59 = 1, the instantaneous power failure or a sudden drop in voltage, the inverter deceleration, when the bus voltage is restored, the drive accelerates to the set frequency normal operation. Analyzing the bus voltage returns to normal is based on the normal bus voltage P9-61 and lasts longer than the set time

If P9-59 = 2, the instantaneous power failure or a sudden drop in voltage, the inverter will decelerate to a stop

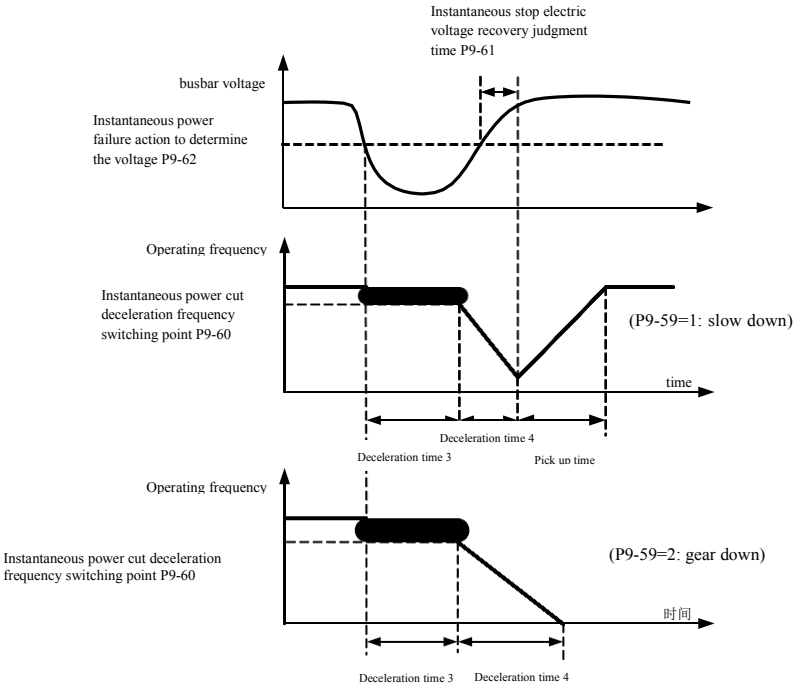

Figure 6-24 Schematic diagram of instantaneous power failure

P9-63	Load missing protection selection	Factory default	0
	Setting range	0	Invalid
		1	Valid
P9-64	Load missing detection level	Factory default	10.0%
	Setting range	0.0%~100.0% (motor rated current)	
P9-65	Load missing testing time	Factory default	1.0s
	Setting range	0.0s~60.0s	

If the load missing protection function is enabled, when the inverter output current is less than carrying out the detection level P9-64, and the duration is greater than the load loss detection time P9-65 when the output frequency is automatically reduced to 7% of the nominal frequency. During the off-load protection, if the load is restored, the drive automatically reverts to run at a set frequency.

P9-67	Over-speed detection value	Factory default	15.0%
	Setting range	0.0% to 50.0% (maximum frequency)	
P9-68	Over-speed detection time	Factory default	2.0s
	Setting range	0.0s~60.0s	

This function is only effective when the inverter running has speed sensor vector control.

When the drive detects the actual speed of the motor exceeds a set frequency, greater than the value exceeds the overspeed detection value P9-67, and the duration is greater than the over-speed detection time P9-68, the inverter fault alarm Err43, according to the fault and the protection mode deal with.

P9-69	Excessive speed deviation detection	Factory default	20.0%
	Setting range	0.0% to 50.0% (maximum frequency)	
P9-70	Excessive speed deviation detection	Factory default	2.0s
	Setting range	0.0s~60.0s	

This function is only effective when the inverter running has speed sensor vector control.

When the drive detects the actual speed of the motor and set frequency deviation, the deviation is greater than the speed deviation detection value P9-69, and the duration is greater than the speed deviation detection time P9-70, the inverter fault alarm Err42, and processed according to the operation mode fault protection.

When the speed deviation detection time is 0.0s, cancel the speed deviation fault detection.

## PA Group--Process control PID function

PID control is a common method of process control by the controlled amount of the difference between the amount of the feedback signal and the target signal is proportional, integral, differential operation by adjusting the output frequency to form a closed-loop system, so that the amount charged in the stable target value.

Suitable for flow control, pressure control and temperature control and process control applications, PID control process block diagram of Figure 6-25.

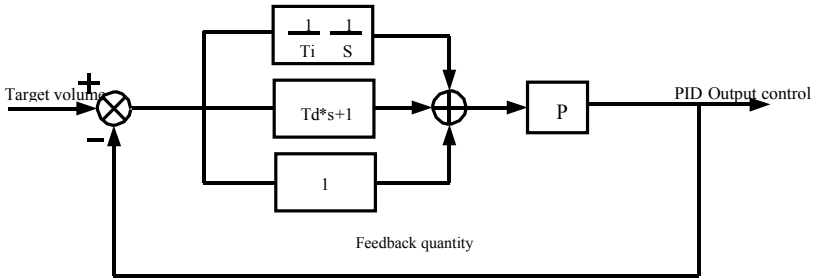

Figure 6-25 Principle block diagram of process PID

PA-00	PID given source		Factory default	0
	Setting range	0	PA-01 Set up	
		1	AI1	
		2	AI2	
		3	AI3	
		4	Pulse (DI5)	
		5	Communication	
		6	Multi-step instructions	
PA-01	PID values given		Factory default	50.0%
	Setting range		0.0%~100.0%	

This parameter is used to select target process PID given channel.

Set a target amount of process PID is a relative value, setting range 0.0% to 100.0%. The same amount is relatively PID feedback amount, PID is the role of these two relatively the same amount.

PA-02	PID feedback source		Factory default	0
	Setting range	0	AI1	
		1	AI2	
		2	AI3	
		3	AI1 - AI2	
		4	Pulse (DI5)	
		5	Communication	
		6	AI1+AI2	
		7	MAX ( AI1 , AI2 )	
		8	MIN ( AI1 , AI2 )	

This parameter is used to select the process PID feedback signal path.

Process PID feedback amount for the relative value is set in the range of 0.0% to 100.0%.

PA-03	PID action direction		Factory default	0
	Setting range	0	Positive action	
		1	eaction	

R Positive effect: When the PID feedback signal is less than a given amount, the inverter output frequency rises. Such as winding tension control applications.

Reaction: When the PID feedback signal is less than a given amount, the output frequency decreases. As Unwinding tension control applications. The impact of the multi-function terminal function by PID action direction negated (function 35), the use of that need attention.

PA-04	PID given feedback range	Factory default	1000
	Setting range	0~65535	

PID given feedback range is dimensionless units for a given display U0-15 PID and PID feedback display U0-16.

Given relative value of feedback PID 100.0%, corresponding to a given feedback range PA-04. For example if the PA-40 is set to 2000, then when PID given 100.0%, PID given display U0-15 2000.

PA-05	Proportional gain Kp 1	Factory default	20.0
	Setting range	0.0~100.0	
PA-06	Integration time Ti 1	Factory default	2.00s
	Setting range	0.01s~10.00s	
PA-07	Differential time Td 1	Factory default	0.000s
	Setting range	0.00~10.000	

Proportional gain Kp 1

Adjusting the intensity of the entire decision PID regulator, Kp1 the greater the greater the intensity. 100.0 This parameter indicates when the PID feedback value and a given amount of deviation of 100.0% when, PID controller to adjust the amplitude of the output frequency command is the maximum frequency.

Integration time Ti 1 Determine the intensity of PID regulator integral adjustment. The shorter the integration time adjustment intensity is. Integration time is when PID feedback quantity and given quantity of deviation of 100.0% of the time integral regulator continuous adjustment in the amount of the maximum frequency.

Differential time Td 1 PID regulator determines the rate of change of the deviation adjustment strength. Differential longer adjustment intensity is. Derivative time refers to the amount of change when the feedback 100.0% during that time, to adjust the amount of the differential regulator for the maximum frequency.

PA-08	PID reverse cut-off frequency	Factory default	2.00Hz
	Setting range	0.00 ~ maximum frequency	

In some cases, only when the PID output frequency is negative (ie, the drive reverse), PID is possible to control the amount of a given quantity and feedback to the same state, but the high frequency inversion is not allowed on some occasions the, PA-08 is used to determine the inversion frequency cap.

PA-09	PID deviation limit	Factory default	0.01%
	Setting range	0.0%~100.0%	

When the PID deviation and feedback value is less than PA-09, PID stops adjustment operation. Thus, given the time and the feedback output frequency deviation of less stable and unchanging, closed-loop control on some occasions very effective.

PA-10	PID differential limiting	Factory default	0.10%
	Setting range	0.00%~100.00%	

PID regulator, the differential effect is more sensitive and is likely to cause system oscillation, therefore, generally regarded PID derivative action is limited to a relatively small area, PA-10 is used to set the PID differential output range.

PA-11	PID given change time	Factory default	0.00s
	Setting range	0.00s~650.00s	

PID given time changes, referring to PID setpoint changes from the 0.0% to 100.0% the time required.

When PID given change, PID setpoint changes linearly with time according to a given change, reduce the adverse effects of a given mutation on the system caused.

PA-12	PID feedback filter time	Factory default	0.00s
	Setting range	0.00s~60.00s	
PA-13	PID output filter time	Factory default	0.00s
	Setting range	0.00s~60.00s	

PA-12 for PID feedback filtering, the filter help to reduce the impact of the amount of feedback is disturbed, but the process will bring the response performance of the closed loop system.

PA-13 for PID output frequency filter, the filter will decrease the output frequency of the mutation, but it will also bring the performance of the process in response to the closed loop system.

PA-15	Proportional gain Kp 2	Factory default	20.0
	Setting range	0.0~100.0	
PA-16	Integration time Ti 2	Factory default	2.00s
	Setting range	0.01s~10.00s	
PA-17	Differential time Td 2	Factory default	0.000s
	Setting range	0.00~10.000	
PA-18	PID parameters switching	Factory default	0
	Setting range	0	Not switch
		1	By DI terminal switch
		2	Automatic switching based on bias
PA-19	PID parameter switching	Factory default	20.0%
	Setting range	0.0%~PA-20	
PA-20	PID parameter switching	Factory default	80.0%
	Setting range	PA-19~100.0%	

In some applications, a set of PID parameters can not meet the needs of the entire operation, and require different PID parameters under different circumstances.

This function code is used to switch two sets of PID parameters. Wherein the regulator parameter PA-15 is set up ~ PA-17, the parameter PA-05 ~ PA-07 is similar.

Two sets of PID parameters can be switched by multifunction digital terminals DI can also be automatically switched according to the deviation of PID.

When choosing a multifunction DI terminal switching, multi-function terminal function selection set to 43 (PID parameters switching terminal), select the parameter set 1 (PA-05 ~ PA-07) when the terminal is invalid, the terminal is valid parameter set selection 2 (PA-15 ~ PA-17).

Choose to automatically switch between the reference and feedback deviation is less than the absolute value of PID parameter switching deviation 1 PA-19 when, PID parameter selection parameter set 1. To a deviation between the reference and the PID feedback is greater than the absolute value of the deviation switch 2 PA-20 Shi, PID parameters select the parameter set 2. To a deviation between the reference and the feedback is switched when the deviation between 1 and switching deviation 2, PID parameters for the two sets of PID parameters of the linear interpolation value, as shown in Figure 6-26.

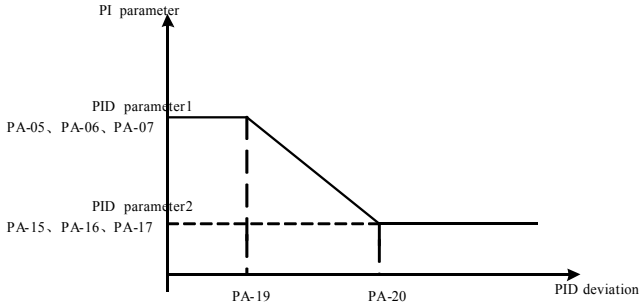

Figure 6-26 PID parameter switching

PA-21	Initial PID	Factory default	0.0%
	Setting range	0.0%~100.0%	
PA-22	PID Initial Hold Time	Factory default	0.00s
	Setting range	0.00s~650.00s	

When the inverter starts, PID output is fixed at the initial value PA-21, continuous PID initial value PA-22 after the holding time, PID loop adjustment operation began.

Figure 6-27 is the initial value of the PID function schematic.

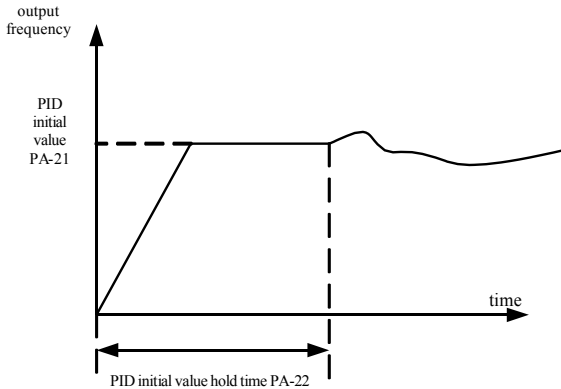

Figure 6-27 is the initial value of the PID function schematic.

This function is used to limit the difference between the two beat PID output (2ms / beat) between the PID output in order to suppress the change too fast, so that the inverter operation to stabilize.



PA-23	Twice forward bias maximum	Factory default	1.00%
	Setting range	0.00%~100.00%	
PA-24	Twice forward bias maximum	Factory default	1.00%
	Setting range	0.00%~100.00%	

PA-23 and PA-24, respectively, and the maximum deviation of the output forward and reverse when the absolute value.

PA-25	PID integral property		Factory default	00
	Setting range	Single digit	Integral Separation	
		0	Invalid	
		1	Valid	
		Ten bit	Integral to whether to stop the output limit after	
		0	Continued integration	
1	Stop Points			

Points separation:

If you set the integral separation effective, when multifunction digital integrator DI pause (function 22) is valid, PID integral PID integral stop operation, only this time PID proportional and derivative actions effective.

When selecting integral separation to be invalid, regardless of whether the DI digital multifunction effective, integral separation are not valid. Integral to whether to stop the output limit after: After PID operation output reaches a maximum or minimum, you can choose whether to stop the integral action. If you choose to stop the integration, at this time PID integral calculation is stopped, which may help reduce the PID overshoot.

PA-26	PID feedback loss detection value	Factory default	0.0%
	Setting range	0.0%: do not judge feedback loss	
PA-27	PID feedback loss detection time	Factory default	1.0s
	Setting range	0.0s~20.0s	

This function code is used to determine whether the loss of PID feedback.

When PID feedback is smaller than the feedback loss detection value of PA-26, and lasts longer than PID feedback loss detection time PA-27, the inverter alarm fault Err31, and troubleshooting process according to the selected mode.

PA-28	PID stoppage operation		Factory default	0
	Setting range	0	Do not stop operation	
		1	Stoppage operation	

PID is used to select the next stop status, PID whether to continue operations. General applications at standstill PID should stop operation.

### PB Group--Swing Frequency, Fixed Length and Counting

Traverse function used in textile, chemical fiber industry, and the need to traverse, winding functions are required. Wobble function means that the inverter output frequency to set the frequency for the center swing up and down, the operating frequency of the track in the timeline.

As shown in Figure 6-28, which swings by the PB-00 and PB-01 set, when PB-01 is set to 0 swing 0, then wobble does not work.

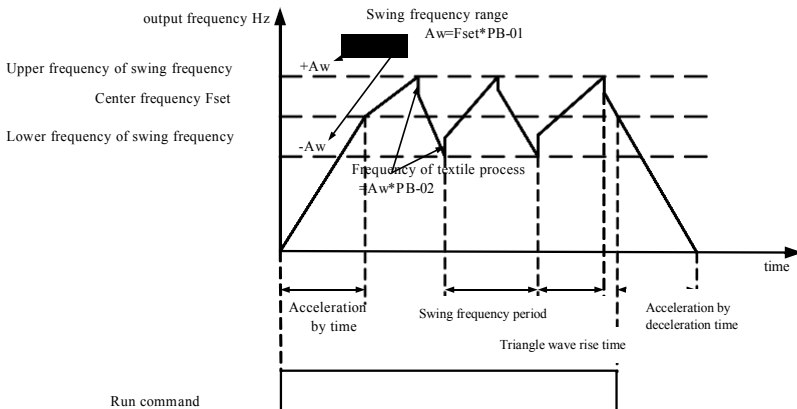

Figure 6-28 Working diagram of frequency swing

PB-00	Radiometric way swing	0	Factory default	0
	Setting range	0	corresponding to central frequency	
		1	Respect to the maximum frequency	

This parameter is determined by reference to the amount of swing.

0: relative to the center frequency (P0-07 frequency source), a variable-swing system. Swing with the center frequency (set frequency) change.

1: Relative maximum frequency (P0-10), the system is constant swing, swing fixed.

PB-01	Wobble amplitude	Factory default	0.0%
	Setting range	0.0%~100.0%	
PB-02	Kick frequency amplitude	Factory default	0.0%
	Setting range	0.0%~50.0%	

To determine the value of the swing and kick frequency value of this parameter.

When set to swing relative to the center frequency (PB-00 = 0), the swing  $AW = \text{frequency source P0-07} \times \text{swing amplitude PB-01}$ . When set to swing with respect to the maximum frequency (PB-00 = 1), the maximum frequency swing  $AW = P0-10 \times \text{swing amplitude PB-01}$ .

Kick frequency amplitude of traverse run, the kick frequency relative to the frequency swing percentage, namely:  $\text{kick frequency} = \text{swing } AW \times \text{kick frequency amplitude PB-02}$ . If the swing amplitude relative to the center frequency (PB-00 = 0), the kick frequency is a variable value. As selected swing relative to the maximum frequency (PB-00 = 1), the kick frequency is a fixed value.

Wobble operating frequency, maximum frequency and minimum frequency is bound by.

PB-03	Wobble cycle	Factory default	10.0s
	Setting range	0.0s~3000.0s	

PB-04	Triangular wave rise time coefficient	Factory default	50.0%
	Setting range	0.0%~100.0%	

Swing frequency cycle: a complete wobble cycle time value.

Triangular wave rise time coefficient PB-04, a triangular wave rising relatively wobble cycle PB-03 percentage of the time.

Triangular wave rise time = Swing frequency cycle PB-03 × triangular wave rising time coefficient PB-04, in seconds.

Triangular wave falling time = Swing frequency cycle PB-03 × (1- triangle wave rise time coefficient PB-04), in seconds.

PB-05	Set length	Factory default	1000m
	Setting range	0m~65535m	
PB-06	Actual length	Factory default	0m
	Setting range	0m~65535m	
PB-07	Number of pulses per meter	Factory default	100.0
	Setting range	0.1~6553.5	

The above function codes for fixed-length control.

Length information you need to enter through the multifunction digital terminal acquisition, the number of sampling pulses terminals and the number of pulses per meter PB-07 phase in addition calculated to give actual length PB-06. When the actual length is greater than the set length PB-05, multi-function digital output DO “Length arrival” ON signal.

Fixed length control process, by multi-function terminal DI carried out the length of the reset operation (DI function selection 28). Please refer to P4-00 ~ P4-09.

Applications need to set the corresponding input terminal function set to “length count input” (function 27), at higher pulse frequency must be used DI5 port.

PB-08	Set count value	Factory default	1000
	Setting range	1~65535	
PB-09	Designated counting value	Factory default	1000
	Setting range	1~65535	

The count value required by multifunction digital input terminal acquisition. Applications need to set the corresponding input terminal function set to “counter input” (function 25), at higher pulse frequency must be used DI5 port.

When the count value reaches the set count value PB-08, multi-function digital output DO “reaching the set count” ON signal, then stop counting.

When the count reaches the designated counting value PB-09, the multi-function digital output DO “reaching the set count” ON signal, when the counting continues until “set count value” counter stopped.

Specified count number PB-09 should not be greater than the set counter value PB-08. Figure 6-29 is reaching the set count and the count value of the specified schematic reach capabilities.

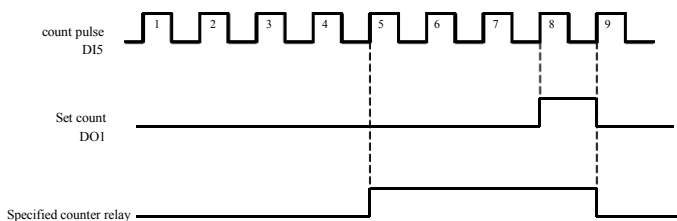

Figure 6-29 Set the number of values given and the specified value of the given diagram

### PC Group--multi-section instructions and simple PLC function

Multi-stage instruction VFD-200G than usual multispeed richer function, in addition to multi-speed function, but also can be used as VF isolated voltage source and a given source of process PID. To this end, the relative values of dimensionless multistage instruction.

Simple PLC function is different from the VFD-200G user-programmable features, easy PLC can only be done on a simple combination of multi-step instructions to run. And user-programmed functions to be richer and more useful, please refer to the A7 group instructions.

PC-00	Multi-stage instruction 0	Factory default	0.0%
	Setting range	-100.0%~100.0%	
PC-01	Multi-stage instruction 1	Factory default	0.0%
	Setting range	-100.0%~100.0%	
PC-02	Multi-stage instruction 2	Factory default	0.0%
	Setting range	-100.0%~100.0%	
PC-03	Multi-stage instruction 3	Factory default	0.0%
	Setting range	-100.0%~100.0%	
PC-04	Multi-stage instruction 4	Factory default	0.0%
	Setting range	-100.0%~100.0%	
PC-05	Multi-stage instruction 5	Factory default	0.0%
	Setting range	-100.0%~100.0%	
PC-06	Multi-stage instruction 6	Factory default	0.0%
	Setting range	-100.0%~100.0%	
PC-07	Multi-stage instruction 7	Factory default	0.0%
	Setting range	-100.0%~100.0%	
PC-08	Multi-stage instruction 8	Factory default	0.0%
	Setting range	-100.0%~100.0%	
PC-09	Multi-stage instruction 9	Factory default	0.0%
	Setting range	-100.0%~100.0%	
PC-10	Multi-stage instruction 10	Factory default	0.0Hz
	Setting range	-100.0%~100.0%	
PC-11	Multi-stage instruction 11	Factory default	0.0%
	Setting range	-100.0%~100.0%	
PC-12	Multi-stage instruction 12	Factory default	0.0%
	Setting range	-100.0%~100.0%	

PC-13	Multi-stage instruction 13	Factory default	0.0%
	Setting range	-100.0%~100.0%	
PC-14	Multi-stage instruction 14	Factory default	0.0%
	Setting range	-100.0%~100.0%	
PC-15	Multi-stage instruction 15	Factory default	0.0%
	Setting range	-100.0%~100.0%	

Multi-step instructions can be used on three occasions: as the frequency source, as VF separate voltage source, as a process PID setting source.

Under three applications, multi-stage instruction dimensionless relative value, range -100.0% to 100.0%. When the frequency source as a percentage of its maximum relative frequency; VF as a separate voltage source, relative to the rated motor voltage percentage; and because PID originally given as a relative value, multi-source does not command as PID set dimension conversion.

Multi-step instruction required depending on the status of multi-function digital DI and switching options, please refer to the P4 group specific instructions.

PC-16	Simple PLC operation mode	Factory default	0
	Setting range	0	Stop at the end of single running
		1	End of single running holding final value
		2	Been circulating

Simple PLC function has two roles: as the frequency source or as VF separate voltage source.

Figure 6-30 is a simplified schematic diagram of the PLC as the frequency source. When simple PLC as the frequency source, PC-00 ~ PC-15 determines the direction of the positive and negative, negative if it means running the drive in the opposite direction.

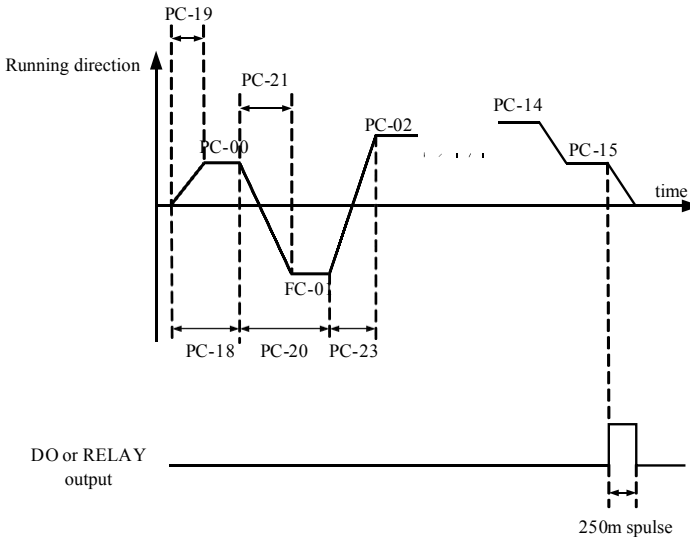

Figure6-30 Schematic diagram of simple PLC

As the frequency source, PLC operates in three ways, as a voltage source does not have VF separation of these three ways. among them:

0: stop at the end of single running

The drive to complete a single cycle stops automatically give a run command to start again.

1: One end of the run to keep the value of the final drive to complete a single cycle, automatically keep running frequency and direction of the last segment.

2: After the cycle has been completed a drive cycle, the next cycle starts automatically, until the stop command to stop.

PC-17	Simple PLC power down memory selection		Factory default	00
	Setting range	Single digit	Power-down memory selection	
		0	Memory is not down	
		1	Power off memory	
		Ten bit	Stop memory selection	
		0	Memory does not stop	
1	Stop memory			

PLC down memory refers to memory before running down phase and frequency PLC running, the next phase will continue to run memory at power-up. Choose not to remember, then every power restart PLC process.

PLC shutdown memory is recorded once before shutdown phase and running frequency PLC running, the next phase will continue to run the memory at runtime. Choose not to remember, every time you restart the PLC process starts.

PC-18	Simple PLC running time of segment 0	Factory default	0.0s (h)
	Setting range	0.0s (h) ~ 6553.5s (h)	
PC-19	Simple PLC deceleration time of segment 0	Factory default	0
	Setting range	0~3	
PC-20	Simple PLC running time of segment 1	Factory default	0.0s (h)
	Setting range	0.0s (h) ~ 6553.5s (h)	
PC-21	Simple PLC deceleration time of segment 1	Factory default	0
	Setting range	0~3	
PC-22	Simple PLC running time of segment 2	Factory default	0.0s (h)
	Setting range	0.0s (h) ~ 6553.5s (h)	
PC-23	Simple PLC deceleration time of segment 2	Factory default	0
	Setting range	0~3	
PC-24	Simple PLC running time of segment 3	Factory default	0.0s (h)
	Setting range	0.0s (h) ~ 6553.5s (h)	
PC-25	Simple PLC deceleration time of segment 3	Factory default	0
	Setting range	0~3	
PC-26	Simple PLC running time of segment 4	Factory default	0.0s (h)
	Setting range	0.0s (h) ~ 6553.5s (h)	
PC-27	Simple PLC deceleration time of segment 4	Factory default	0
	Setting range	0~3	

PC-28	Simple PLC running time of segment 5	Factory default	0.0s (h)
	Setting range	0.0s (h) ~6553.5s (h)	
PC-29	Simple PLC deceleration time of segment 5	Factory default	0
	Setting range	0~3	
PC-30	Simple PLC running time of segment 6	Factory default	0.0s (h)
	Setting range	0.0s (h) ~6553.5s (h)	
PC-31	Simple PLC deceleration time of segment 6	Factory default	0
	Setting range	0~3	
PC-32	Simple PLC running time of segment 7	Factory default	0.0s (h)
	Setting range	0.0s (h) ~6553.5s (h)	
PC-33	Simple PLC deceleration time of segment 7	Factory default	0
	Setting range	0~3	
PC-34	Simple PLC running time of segment 8	Factory default	0.0s (h)
	Setting range	0.0s (h) ~6553.5s (h)	
PC-35	Simple PLC deceleration time of segment 8	Factory default	0
	Setting range	0~3	
PC-36	Simple PLC running time of segment 9	Factory default	0.0s (h)
	Setting range	0.0s (h) ~6553.5s (h)	
PC-37	Simple PLC deceleration time of segment 9	Factory default	0
	Setting range	0~3	
PC-38	Simple PLC running time of segment 10	Factory default	0.0s (h)
	Setting range	0.0 s (h) ~6553.5s (h)	
PC-39	Simple PLC deceleration time of segment 10	Factory default	0
	Setting range	0~3	
PC-40	Simple PLC running time of segment 11	Factory default	0.0s (h)
	Setting range	0.0s (h) ~6553.5s (h)	
PC-41	Simple PLC deceleration time of segment 11	Factory default	0
	Setting range	0~3	
PC-42	Simple PLC running time of segment 12	Factory default	0.0s (h)
	Setting range	0.0s (h) ~6553.5s (h)	
PC-43	Simple PLC deceleration time of segment 12	Factory default	0
	Setting range	0~3	
PC-44	Simple PLC running time of segment 13	Factory default	0.0s (h)
	Setting range	0.0s (h) ~6553.5s (h)	
PC-45	Simple PLC deceleration time of segment 13	Factory default	0
	Setting range	0~3	
PC-46	Simple PLC running time of segment 14	Factory default	0.0s (h)
	Setting range	0.0s (h) ~6553.5s (h)	

PC-47	Simple PLC deceleration time of segment 14		Factory default	0
	Setting range		0~3	
PC-48	Simple PLC running time of segment 15		Factory default	0.0s (h)
	Setting range		0.0s (h) ~ 6553.5s (h)	
PC-49	Simple PLC deceleration time of segment 15		Factory default	0
	Setting range		0~3	
PC-50	Simple PLC run time unit		Factory default	0
	Setting range	0	S (s)	
		1	h (h)	
PC-5	Multi-segment instruction 0 given mode		Factory default	0
	Setting range	0	Function code FC-00 given	
		1	AI1	
		2	AI2	
		3	AI3	
		4	Pulse	
		5	PID	
		6	Preset frequency (P0-08) given, UPTOWN editable	

This parameter determines the multi-0 instruction given channel.

Multi-step instructions 0 PC-00 can be selected in addition, there are many other options to facilitate between multiple short instructions given with the other mode switching. When the multi-frequency source or instruction as simple as a PLC frequency source, can easily switch between the two to achieve frequency source.

PD Group--Communication parameters

Refer to *VFD-200G protocol*

PE Group--Custom function code

PE-00	User Function Code 0		Factory default	P0.00
	Setting range		P0.00~PP.xx, A0.00~Ax.xx, U0.xx	
PE-01	User Function Code 1		Factory default	P0.02
	Setting range		P0.00~PP.xx, A0.00~Ax.xx, U0.xx	
PE-02	User Function Code 2		Factory default	P0.03
	Setting range		P0.00~PP.xx, A0.00~Ax.xx, U0.xx	
PE-03	User Function Code 3		Factory default	P0.07
	Setting range		P0.00~PP.xx, A0.00~Ax.xx, U0.xx	
PE-04	User Function Code 4		Factory default	P0.08
	Setting range		P0.00~PP.xx, A0.00~Ax.xx, U0.xx	
PE-05	User Function Code 5		Factory default	P0.17
	Setting range		P0.00~PP.xx, A0.00~Ax.xx, U0.xx	



PE-06	User Function Code 6	Factory default	P0.18
	Setting range	P0.00~PP.xx, A0.00~Ax.xx, U0.xx	
PE-07	User Function Code 7	Factory default	P3.00
	Setting range	P0.00~PP.xx, A0.00~Ax.xx, U0.xx	
PE-08	User Function Code 8	Factory default	P3.01
	Setting range	P0.00~PP.xx, A0.00~Ax.xx, U0.xx	
PE-09	User Function Code 9	Factory default	P4.00
	Setting range	P0.00~PP.xx, A0.00~Ax.xx, U0.xx	
PE-10	User Function Code 10	Factory default	P4.01
	Setting range	P0.00~PP.xx, A0.00~Ax.xx, U0.xx	
PE-11	User Function Code 11	Factory default	P4.02
	Setting range	P0.00~PP.xx, A0.00~Ax.xx, U0.xx	
PE-12	User Function Code 12	Factory default	P5.04
	Setting range	P0.00~PP.xx, A0.00~Ax.xx, U0.xx	
PE-13	User Function Code 13	Factory default	P5.07
	Setting range	P0.00~PP.xx, A0.00~Ax.xx, U0.xx	
PE-14	User Function Code 14	Factory default	P6.00
	Setting range	P0.00~PP.xx, A0.00~Ax.xx, U0.xx	
PE-15	User Function Code 15	Factory default	P6.10
	Setting range	P0.00~PP.xx, A0.00~Ax.xx, U0.xx	
PE-16	User Function Code 16	Factory default	P0.00
	Setting range	P0.00~PP.xx, A0.00~Ax.xx, U0.xx	
PE-17	User Function Code 17	Factory default	P0.00
	Setting range	P0.00~PP.xx, A0.00~Ax.xx, U0.xx	
PE-18	User Function Code 18	Factory default	P0.00
	Setting range	P0.00~PP.xx, A0.00~Ax.xx, U0.xx	
PE-19	User Function Code 19	Factory default	P0.00
	Setting range	P0.00~PP.xx, A0.00~Ax.xx, U0.xx	
PE-20	User Function Code 20	Factory default	P0.00
	Setting range	P0.00~PP.xx, A0.00~Ax.xx, U0.xx	
PE-21	User Function Code 21	Factory default	P0.00
	Setting range	P0.00~PP.xx, A0.00~Ax.xx, U0.xx	
PE-22	User Function Code 22	Factory default	P0.00
	Setting range	P0.00~PP.xx, A0.00~Ax.xx, U0.xx	
PE-23	User Function Code 23	Factory default	P0.00
	Setting range	P0.00~PP.xx, A0.00~Ax.xx, U0.xx	
PE-24	User Function Code 24	Factory default	P0.00
	Setting range	P0.00~PP.xx, A0.00~Ax.xx, U0.xx	

PE-25	User Function Code 25	Factory default	P0.00
	Setting range	P0.00~PP.xx, A0.00~Ax.xx, U0.xx	
PE-26	User Function Code 26	Factory default	P0.00
	Setting range	P0.00~PP.xx, A0.00~Ax.xx, U0.xx	
PE-27	User Function Code 27	Factory default	P0.00
	Setting range	P0.00~PP.xx, A0.00~Ax.xx, U0.xx	
PE-28	User Function Code 28	Factory default	P0.00
	Setting range	P0.00~PP.xx, A0.00~Ax.xx, U0.xx	
PE-29	User Function Code 29	Factory default	P0.00
	Setting range	P0.00~PP.xx, A0.00~Ax.xx, U0.xx	

This function code is customized parameter set.

Users can all VFD-200G function code, select the desired parameter aggregated into PE group, as a user customized parameters for easy viewing and changing operations.

PE group provides up to 30 custom parameter, PE group parameter display is P0.00, it means that the user function code is empty. When entering custom parameters mode, display the function code PE-00 ~ PE-31 is defined by the order consistent with the PE group function code, skip to P0-00

### PP Group--User password

PP-00	User Password	Factory default	0
	Setting range	0~65535	

PP-00 to set an arbitrary non-zero number, the password protection function. The next time you enter the menu, you must enter the correct password, or can not view and modify function parameters, please remember the password set by the user.

PP-00 is set to 00000, then clear the user password set, the password protection function is invalid.

PP-01	Parameter Initialization		Factory default	0
	Setting range	0	No operation	
		1	Restore factory settings, not including the motor parameters	
		2	Clear History Information	
		4	Current backup user parameters	
501	Recover user backup parameters			

1. Restore factory settings, excluding motor parameters

PP-01 is set to 1, most inverter function parameters are restored to the factory default parameters, but motor parameters, frequency command decimal point (P0-22), fault recording information, total running time (P7-09), the cumulative power time (P7-13), the total power consumption (P7-14) is not restored.

2. Clear History Information

Clear fault record information drive, total running time (P7-09), the cumulative power-up time (P7-13), the total power consumption (P7-14).

4. The current parameter backup user

The current backup parameters set by the user. The current value of all settings function parameters back down. To facilitate customers in the parameter adjustment disorder after recovery.

501, restore the user parameters previously backed up user parameters backup recovery, the recovery by setting PP-01 for the four backup parameter.

PP-02	Function parameter display properties		Factory default	11
	Setting range	Single digit	U group display selection	
		0	Do not show	
		1	Show	
		Ten bit	A group display selection	
		0	Do not show	
1		Show		
PP-02	Function parameter display properties		Factory default	11
	Setting range	Single digit	U group display selection	
		0	Do not show	
		1	Show	
		Ten bit	A group display selection	
		0	Do not show	
1		Show		

Set up parameter display mode is mainly based on the actual user needs to view a different arrangement in the form of function parameters, provides three parameters display,

Name	Description
Function parameters mode	Sequential display drive parameters, respectively, P0 ~ PF, A0 ~ AF, U0 ~ UF parameter group
Customized parametrical mode by users	Individual function parameters customized display (up to 32 customized), FE user group to determine the function of the parameters to be displayed
Parameter changing mode by users	Inconsistent with the factory parameter function parameters

When the character mode display selection parameter (PP-03) when there is a show, this time can be switched to different parameters by QSM key display mode, the default is the only function parameter display.

Parameter display mode	show
Function parameters mode	- b A S F
Customized parametrical mode by users	- U S E r
Parameter changing mode by users	- - f - -

Each parameter display mode displays coded as:

VFD-200G drive offers two personalized parameter display mode: The user customized parameters, the user change the parameter mode. Customized parameter sets for the user to set the parameters of PE group, you can select the maximum 32 parameters, which are aggregated together, customers can easily debug.

User customized parameters manner, before custom function code to add a default symbol u example: P1-00, in the custom parameter mode, the display for the user to change parameters for the uP1-00 way for users and manufacturers have to change in order to factory setting different parameters. User parameter set change in favor of the customer to view a summary of the parameters change, facilitate on-site to find the problem.

The user change the parameter mode, before the custom function code to add a default symbol c

For example: P1-00, change parameters in the user mode, the display is as cP1-00

PP-04	Function code to modify the properties		Factory default	0
	Setting range	0	Can be modified	
		1	Unmodifiable	

Whether the user function code parameter setting can be modified to prevent the risk of function parameters are mistakenly altered.

The function code is set to 0, all the function codes can be modified; while set to 1, all the function codes are only view can not be modified.

**A0 Group --Torque control group and define parameters**

A0-00	Speed / torque control mode selection		Factory default	0
	Setting range	0	Speed Control	
		1	Torque Control	

For selecting inverter control mode: Speed control or torque control.

DI VFD-200G multifunction digital terminals, and has two functions associated with torque control: Torque control disabled (function 29), speed control / torque control switching (function 46). These two terminals keep A0-00 in conjunction to achieve switching speed and torque control.

When the speed control / torque control switch terminal is invalid, the control mode is determined by the A0-00, if speed control / torque control switch is active, the control mode is equivalent to the value of A0-00 negated.

In any case, when the torque control prohibition terminal is valid, inverter fixed speed control.

A0-01	Torque in torque control mode setting source selection		Factory default	0
	Setting range	0	Number setting (A0-03)	
		1	AI1	
		2	AI2	
		3	AI3	
		4	Pulse	
		5	Communication given	
		6	MIN (AI1, AI2)	
7		MAX (AI1, AI2)		
A0-03	Torque number setting in torque control mode		Factory default	0
	Setting range	-200.0%~200.0%		

A0-01 torque setting is used to select the source, a total of 8 torque setting mode.

Torque setting using a relative value, corresponding to 100.0% inverter rated torque. Setting range -200.0% to 200.0%, indicating that the inverter maximum torque is 2 times the rated drive torque.

When the torque setting by way of 1 to 7, communications, analog input, pulse input of 100% corresponds to A0-03.

A0-05	Torque control positive maximum		Factory default	50.00Hz
	Setting range		0.00Hz ~ maximum frequency (P0-10)	

A0-06	Torque control negative maximum	Factory default	50.00Hz
	Setting range	0.00Hz ~ maximum frequency (P0-10)	

It is used to set the torque control mode, the drive forward or reverse maximum operating frequency.

When the drive torque control, if the load torque is less than the output torque of the motor, the motor speed will continue to rise, in order to prevent the mechanical system appears coaster accidents, it must be limited to the maximum torque of the motor speed control.

A0-07	Torque control acceleration time	Factory default	0.00s
	Setting range	0.00s~65000s	
A0-08	Torque control deceleration time	Factory default	0.00s
	Setting range	0.00s~65000s	

Torque control mode, the motor output torque and load torque difference determines the speed and rate of change of the motor load, so it is possible to quickly change the motor speed, causing noise or excessive mechanical stress and other issues. By setting the torque control acceleration and deceleration time, the motor speed can be so gradual change.

However, the need for rapid response in case of torque, set the torque control acceleration and deceleration time is 0.00s. For example: Two hard-wired motor drag the same load, to ensure that the load is evenly distributed, set up a drive for the host, using the speed control mode, the drive from another machine and using the actual output torque control switch, host moments torque command as a slave, this time the torque required to follow the host machine's fast, slave torque control acceleration and deceleration time is 0.00s.

### A2 Group--2<sup>nd</sup> motor

VFD-200G can be switched between two motor, two motors can be set to the motor nameplate, respectively, can be the motor parameter tuning, respectively, can be selected VF control or vector control, you can set the encoder parameters, respectively, may be provided with VF control alone or vector control performance related parameters.

A2 group function code corresponds to the motor 2.

At the same time, all the parameters A2 group, the definition and use of its contents are consistent with the parameters of the 1<sup>st</sup> motor, not repeated here, the user can refer to the first motor-related parameter description.

A2-00	Motor type selection	Factory default	0
	Setting range	0	General induction motor
		1	Variable frequency induction motor
A2-01	Rated power	Factory default	Model determination
	Setting range	0.1kW~1000.0kW	
A2-02	rated voltage	Factory default	Model determination
	Setting range	1V~400V	
A2-03	Rated current	Factory default	Model determination
	Setting range	0.01A~655.35A(frequency converter power <=55kW) 0.1A~6553.5A(frequency converter power >55kW)	
A2-04	rated frequency	Factory default	Model determination
	Setting range	0.01Hz~Maximum frequency	

A2-05	rated speed		Factory default	Model determination
	Setting range		1rpm~65535rpm	
A2-06	Induction motor stator resistance		Factory default	Model determination
	Setting range		0.001Ω~65.535Ω(frequency converter power ≤55kW) 0.0001Ω~6.5535Ω(frequency converter power >55kW)	
A2-07	Rotor resistance of induction motor		Factory default	Model determination
	Setting range		0.001Ω~65.535Ω(frequency converter power ≤55kW) 0.0001Ω~6.5535Ω(frequency converter power >55kW)	
A2-08	The leakage inductance of asynchronous motor		Factory default	Model determination
	Setting range		0.01mH~655.35mH(frequency converter power ≤55kW) 0.001mH~65.535mH(frequency converter power >55kW)	
A2-09	Induction motor mutual inductance		Factory default	Model determination
	Setting range		0.1mH~6553.5mH(frequency converter power ≤55kW) 0.01mH~655.35mH(frequency converter power >55kW)	
A2-10	No-load current of induction motor		Factory default	Model determination
	Setting range		0.01A~A2-03(frequency converter power ≤55kW) 0.1A~A2-03(frequency converter power >55kW)	
A2-27	Encoder line number		Factory default	1024
	Setting range		1~65535	
A2-28	Speed fbk sel		Factory default	0
	Setting range	0	ABZ incremental encoder	
		1	Retention	
		2	Rotating transformer	
A2-29	Speed feedback PG selection		Factory default	0
	Setting range	0	Local PG	
		1	Extension PG	
		2	PULSE pulse input (DI5)	
A2-30	ABZ incremental encoder AB sequence		Factory default	0
	Setting range	0	forward direction	
		1	reverse	
A2-34	Pole pairs of rotating transformer		Factory default	1
	Setting range		1~65535	
A2-36	Speed feedback PG disconnection detection time		Factory default	0.0s
	Setting range		0.0: failure to actuate 0.1s~10.0s	

A2-37	Tuning selection		Factory default	0
	Setting range	0	No operation	
		1	Asynchronous machine static tuning	
		2	Full tuning of asynchronous machines	
A2-38	Speed loop proportional gain 1		Factory default	30
	Setting range		1~100	
A2-39	Speed loop integral time 1		Factory default	0.50s
	Setting range		0.01s~10.00s	
A2-40	Switching frequency 1		Factory default	5.00Hz
	Setting range		0.00~A2-43	
A2-41	Speed loop proportional gain 2		Factory default	15
	Setting range		0~100	
A2-42	Speed loop integral time 2		Factory default	1.00s
	Setting range		0.01s~10.00s	
A2-43	Switching frequency 2		Factory default	10.00Hz
	Setting range		A2-40~Maximum output frequency	
A2-44	Vector control transfer gain		Factory default	100%
	Setting range		50%~200%	
A2-45	Velocity loop filter time constant		Factory default	0.000s
	Setting range		0.000s~0.100s	
A2-46	Vector control over excitation gain		Factory default	64
	Setting range		0~200	
A2-47	Speed control mode of the torque limit source		Factory default	0
	Setting range	0	A2-48 setting	
		1	AI1	
		2	AI2	
		3	AI3	
		4	PULSE setting	
		5	Communication setting	
		6	MIN (AI1,AI2)	
7	MAX (AI1,AI2)			
A2-48	Speed control mode digital setting of torque limit		Factory default	150.0%
	Setting range		0.0%~200.0%	
A2-51	Excitation regulator proportional gain		Factory default	2000
	Setting range		0~20000	

A2-52	Excitation regulation integral gain	Factory default	1300
	Setting range	0~20000	
A2-53	Torque control proportional gain	Factory default	2000
	Setting range	0~20000	
A2-54	Torque control integral gain	Factory default	1300
	Setting range	0~20000	
A2-55	Velocity loop integral property	Factory default	0
	Setting range	Single digit: Integral separatio 0: invalid 1: valid	
A2-61	Second motor control mode	Factory default	0
	Setting range	0	Speed sensorless vector control (SVC)
		1	Speed sensor vector control (FVC)
		2	V/F 控制
A2-62	Second motor plus deceleration time selection	Factory default	0
	Setting range	0	The same as the first motor
		1	Plus deceleration time 1
		2	Plus deceleration time 2
		3	Plus deceleration time 3
		4	Plus deceleration time 4
A2-63	Second motor torque	Factory default	Model determination
	Setting range	0.0%: Automatic torque lifting 0.1%~30.0%	
A2-65	Second motor oscillation suppression gain	Factory default	Model determination
	Setting range	0~100	

### A5 Group-- Control optimization parameters

A5-00	DPWM switching frequency	Factory default	12.00Hz
	Setting range	0.00Hz~15Hz	

It is only valid for VF control. Hair wave asynchronous machine VF runtime determine, below this value to 7-segment continuous modulation scheme, on the contrary, compared with 5 of intermittent modulation.

7-segment continuous modulation of the inverter switching loss is large, but it will bring the current ripple is small; 5 paragraph intermittent debug mode switching loss is small, a large current ripple; but at high frequencies may cause instability motor, generally do not need to be modified.

About VF run instability refer to function code P3-11, loss and temperature rise on the drive, please refer to the function code P0-15;



A5-01	PWM modulation		Factory default	0
	Setting range	0	Asynchronous modulation	
		1	Synchronous modulation	

It is only valid for VF control. Synchronous modulation means converting the carrier frequency as the output frequency varies linearly, to ensure both the ratio (carrier ratio) unchanged, generally at higher output frequencies to use, in favor of the quality of the output voltage.

In the lower output frequency (100Hz or less), generally you do not need synchronous modulation, because the ratio of the carrier frequency and the output frequency is relatively high, some of the more obvious advantages of asynchronous modulation.

Running frequency higher than 85Hz, synchronous modulation to take effect, the frequency of the following fixed asynchronous modulation mode.

A5-02	Dead compensation mode selection		Factory default	1
	Setting range	0	Without compensation	
		1	Compensation Mode 1	
		2	Compensation Mode 2	

Generally do not need to modify this parameter, only when the output voltage waveform quality have special requirements, or other abnormal motor oscillation, you need to try to switch to select different compensation models.

Mode 2 is recommended to use high-power compensation.

A5-03	Random PWM Depth		Factory default	0
	Setting range	0	Random PWM invalid	
		1~10	PWM carrier frequency random depth	

Set random PWM, the motor can be monotonous shrill voice becomes softer and can help reduce the external electromagnetic interference.

When set to 0 random PWM depth, random PWM invalid. Different depth adjustment random PWM will get different results.

A5-04	Enable fast limiting		Factory default	1
	Setting range	0	Not enable	
		1	Enable	

Enable fast current limiting function can reduce the maximum drive overcurrent fault occurs. The drive to ensure uninterrupted operation. If the drive for a long period in the fast current limit, the inverter may overheat and other damage, and this is not allowed.

So long drive quickly when the alarm limit fault Err40, indicating that the inverter overload and downtime.

A5-05	Current detection compensation	Factory default	5
	Setting range	0~100	

Current detection compensation for setting inverter control set too high may cause performance degradation. Generally do not need to modify.

A5-06	Brown-point setting	Factory default	100.0%
	Setting range	60.0%~140.0%	

For setting undervoltage fault Err09 voltage value, different voltage levels of the inverter 100.0% are corresponding to different voltage points, namely:

220V single-phase or three-phase 220V: 200V Three-phase 380V: 350V

A5-07	SVC optimization model		Factory default	1
	Setting range	0	not optimize	
		1	optimization model 1	
		2	optimization model 2	

Optimization Mode 1: There is a high torque control linearity requirements when using

Optimized Mode 2: Use a higher speed stability requirements

A5-08	Dead-time adjustment	Factory default	150%
	Setting range	100%~200%	

#### A6 group: AI curve setting

A6-00	Min. input of AI curve 4	Factory default	0.00V
	Setting range	-10.00V~A6-02	
A6-01	Setting for min. input of AI curve 4	Factory default	0.0%
	Setting range	-100.0%~100.0%	
A6-02	Input of inflection point 1 of AI curve 4	Factory default	3.00V
	Setting range	A6-00~A6-04	
A6-03	Setting for input of inflection point	Factory default	30.0%
	Setting range	-100.0%~100.0%	
A6-04	Input of inflection point 2 of AI curve 4	Factory default	6.00V
	Setting range	A6-02~A6-06	
A6-05	Setting for input of inflection point	Factory default	60.0%
	Setting range	-100.0%~100.0%	
A6-06	Max. input of AI curve 4	Factory default	10.00V
	Setting range	A6-06~10.00V	
A6-07	Setting for max. input of AI curve 4	Factory default	100.0%
	Setting range	-100.0%~100.0%	
A6-08	Min. input of AI curve 4	Factory default	0.00V
	Setting range	-10.00V~A6-10	
A6-09	Setting for min. input of AI curve 4	Factory default	
	Setting range	-100.0%~100.0%	
A6-10	Input of inflection point 1 of AI curve 5	Factory default	
	Setting range	A6-08~A6-12	
A6-11	Setting for input of inflection point 1 of AI curve 5	Factory default	
	Setting range	-100.0%~100.0%	

A6-12	Input of inflection point 2 of AI curve 5	Factory default	6.00V
	Setting range	A6-10~A6-14	
A6-13	Setting for input of inflection point 2 of AI curve 5	Factory default	60.0%
	Setting range	-100.0%~100.0%	
A6-14	Max. input of AI curve 5	Factory default	10.00V
	Setting range	A6-14~10.00V	
A6-15	Setting for max. input of AI curve 5	Factory default	100.0%
	Setting range	-100.0%~100.0%	

Curve function curve 4 and curve 5 1 to 3 is similar to the curve, but the curve 1 to curve 3 a straight line and the curve 4 and curve 5 for the 4-point curve, you can achieve a more flexible correspondence. Figure 6-32 is a schematic curve curve 4 to 5.

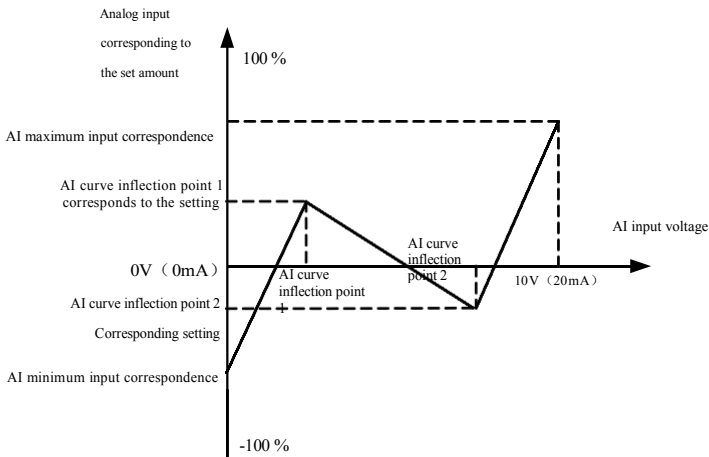

Figure 6-32 Curves 4 and 5 wiring diagram

Curve 4 and 5 to set the curve should note that the minimum input voltage curve, the inflection point voltage 1, 2 inflection point voltage, maximum voltage must be successively increased.

AI curve selection P33 is used to determine the analog input AI1 ~ AI3 how to choose five curves.

A6-24	AI1 sets jump point	Factory default	0.0%
	Setting range	-100.0%~100.0%	
A6-25	AI1 sets jump range	Factory default	
	Setting range	0.0%~100.0%	
A6-26	AI2 sets jump point	Factory default	
	Setting range	-100.0%~100.0%	
A6-27	AI2 sets jump range	Factory default	
	Setting range	0.0%~100.0%	

A6-28	AI3 sets jump point	Factory default	0.0%
	Setting range	-100.0%~100.0%	
A6-29	AI3 sets jump range	Factory default	0.5%
	Setting range	0.0%~100.0%	

VFD-200G analog input AI1 ~ AI3, possess setpoint skip function.

Skip function means that when a corresponding analog set point jump up and down when the interval changes, the analog value corresponding to the set point value is fixed at the jump.

Example: Analog input AI1 voltage at 5.00V fluctuations, fluctuation in the range of 4.90V ~ 5.10V, AI1 minimum input 0.00V corresponds to 0.0%, the maximum input 10.00V corresponds to 100.%, then detected the corresponding setting AI1 between 49.0% ~ 51.0% volatility.

Setting AI1 setting jump points A6-24 50.0%, set AI1 setting A6-25 jump amplitude of 1.0%, and then the above AI1 input, after the jump function to give the corresponding input of AI1 setting is fixed at 50.0% AI1 is converted into a stable input, eliminating fluctuations.

A7 group--User-programmable functions

See *User-programmable controller card Supplementary Manual*.

AC group: AIAO calibration

AC-00	AI1 measured voltage 1	Factory default	Calibration
	Setting range	0.500V~4.000V	
AC-01	AI1 display voltage 1	Factory default	Calibration
	Setting range	0.500V~4.000V	
AC-02	AI1 measured voltage 2	Factory default	Calibration
	Setting range	6.000V~9.999V	
AC-03	AI1 display voltage 2	Factory default	Calibration
	Setting range	6.000V~9.999V	
AC-04	AI2 measured voltage 1	Factory default	Calibration
	Setting range	0.500V~4.000V	
AC-05	AI2 display voltage 1	Factory default	Calibration
	Setting range	0.500V~4.000V	
AC-06	AI2 measured voltage 2	Factorydefault	Calibration
	Setting range	6.000V~9.999V	
AC-07	AI2 display voltage 2	Factory default	
	Setting range	-9.999V~10.000V	
AC-08	AI3 measured voltage 1	Factory default	
	Setting range	-9.999V~10.000V	
AC-09	AI3 display voltage 1	Factory default	
	Setting range	-9.999V~10.000V	

AC-10	AI3 measured voltage 2	Factory default	Calibration
	Setting range	-9.999V~10.000V	
AC-11	AI3 display voltage 2	Factory default	Calibration
	Setting range	-9.999V~10.000V	

The function code is used for analog input AI is corrected to eliminate the effect of AI input bias and gain. The group function parameter had been corrected, restoring factory value, it returns to the factory value after correction. Usually the application site does not require correction.

Found voltage means, such as a multimeter measuring instruments to measure out actual voltage, voltage refers to the display inverter out of the sampled voltage value is displayed, see U0 group AI before correction voltage (U0-21, U0-22, U0-23) display.

When the correction in each AI input port of each two input voltage values, respectively, the multimeter to measure the value of the group read the value of U0 group, accurate input to the function codes, the inverter will automatically AI zero bias and gain correction.

AC-12	A01 target voltage 1	Factory default	Calibration
	Setting range	0.500V~4.000V	
AC-13	A01 measured voltage 1	Factory default	Calibration
	Setting range	0.500V~4.000V	
AC-14	A01 target voltage 2	Factory default	Calibration
	Setting range	6.000V~9.999V	
AC-15	A01 measured voltage 2	Factory default	Calibration
	Setting range	6.000V~9.999V	
AC-16	A02 target voltage 1	Factory default	Calibration
	Setting range	0.500V~4.000V	
AC-17	A02 measured voltage 1	Factory default	Calibration
	Setting range	0.500V~4.000V	
AC-18	A02 target voltage 2	Factory default	Calibration
	Setting range	6.000V~9.999V	
AC-19	A02 measured voltage 2	Factory default	Calibration
	Setting range	6.000V~9.999V	

The function code is used for analog input AO is corrected to eliminate the effect of AI input bias and gain. The group function parameter had been corrected, restoring factory value, it returns to the factory value after correction. Usually the application site does not require correction.

Target voltage refers to the theoretical value of the inverter output voltage. Found voltage refers measured by instruments such as multimeters actual output voltage value.

## U0 Group--Monitoring

U0 parameter group is used to monitor the inverter operation status information, customers can view the panel, in order to facilitate on-site commissioning, set parameter values can also be read through communication, for PC monitor. Wherein, U0-00 ~ U0-31 is run down and monitoring parameters P7-03 and P7-04 defined.

See specific parameters function code, parameter name and the smallest unit in Table 6-1 .

Figure 6-1 Parameters of U0

group

Function code	Name	Unit
U0-00	Running frequency (Hz)	0.01Hz
U0-01	Setting frequency (Hz)	0.01Hz
U0-02	Busbar voltage (V)	0.1V
U0-03	Output voltage (V)	1V
U0-04	Output current (A)	0.01A
U0-05	Output power (kW)	0.1kW
U0-06	Output torque (%)	0.1%
U0-07	DI input state	1
U0-08	DO output state	1
U0-09	AI1 voltage (V)	0.01V
U0-10	AI2 voltage (V)	0.01V
U0-11	AI3 voltage (V)	0.01V
U0-12	Count value	1
U0-13	Length value	1
U0-14	Loading speed display	1
U0-15	PID setting	1
U0-16	PID feedback	1
U0-17	PLC stage	1
U0-18	Input PULSE frequency (Hz)	0.01kHz
U0-19	Feedback speed (0.1Hz)	0.1Hz
U0-20	Surplus operation run	0.1Min
U0-21	AI1 voltage before calibration	0.001V
U0-22	AI2 voltage before calibration	0.001V
U0-23	AI3 voltage before calibration	0.001V
U0-24	Linear speed	1m/Min
U0-25	Current electrifying time	1Min
U0-26	Current running time	0.1Min
U0-27	Input PULSE frequency	1Hz
U0-28	Communication given value	0.01%
U0-29	Feedback speed of encoder	0.01Hz
U0-30	Display of main frequency X	0.01Hz

Function code	Name	Unit
U0-31	Display of auxiliary frequency Y	0.01Hz
U0-32	View any memory address value	1
U0-34	Motor temperature	1 °C
U0-35	Target torque (%)	0.1%
U0-36	Rotating location	1
U0-37	Angle of power factor	0.1
U0-39	VF separates target voltage	1V
U0-40	VF separates output voltage	1V
U0-41	Visual display of DI input state	1
U0-42	Visual display of DO input state	1
U0-43	Visual display 1 of DI function state	1
U0-44	Visual display 2 of DI function state	1
U0-45	Setting frequency (%)	0
U0-59	Running frequency (%)	0.01%
U0-60	State of frequency convertor	0.01%
U0-61	Display of auxiliary frequency Y	1
U0-62	View any memory address value	1

## Chapter 7 EMC (Electromagnetic compatibility)

### 7.1 Definition

Electromagnetic compatibility means that electrical equipment operates under environment of electromagnetic interference, but it does not interfere electromagnetic environment and realizes the function stably.

### 7.2 Introduction of EMC standard

According to requirements of national standard GB/T12668.3, frequency converter shall conform to requirements of two aspects: electromagnetic interference and anti-electromagnetic interference.

Our current products execute latest international standards: IEC/EN61800-3: 2004 (Adjustable speed electrical power drive systems part 3: EMC requirements and specific test methods), which is equal to national standard GB/T12668.3.

IEC/EN61800-3 mainly checks frequency converter from two aspects: electromagnetic interference and anti-electromagnetic interference. Electromagnetic interference mainly tests radiated interference, conducted interference and harmonic interference of frequency converter (requirements on the frequency converter for civil use). Anti-electromagnetic interference mainly tests conduction immunity, radiated immunity, surge immunity, fast changed pulse group, ESD immunity and immunity of low-frequency terminal of power (specific test items include: 1. immunity test for input voltage sag, interruption and change; 2. immunity test for commutation notch; 3. immunity test for harmonic input; 4. change test for input frequency; 5. unbalance test for input voltage; 6. fluctuation test for input voltage). The test is conducted as per strict requirements of above IEC/EN61800-3, and please install our company products as per instructions of 7.3, which own good electromagnetic compatibility under general industry environment.

### 7.3 EMC guidance

7.3.1 Influence of harmonic: higher harmonic of power will damage frequency converter, so it's suggested to install AC input reactor in the places with weak quality of power grid.

7.3.2 Electromagnetic interference and installing precautions: there are two kinds of electromagnetic interference. One is interference of surrounding electromagnetic noise for frequency converter, and another is interference produced by frequency converter for peripheral equipments.

Installing precautions:

- 1) Earthing wire of frequency converter and other electrical products should be well grounded;
- 2) Do not layout power input and output line or weak current signal line (e.g. control circuit) of frequency converter in parallel, layout them vertically if possible;
- 3) It's suggested to use shield cable or steel tube shield power line for output power line of frequency converter, and keep reliable earthing of shield layer. For the lead of equipment with interference, it's suggested to use dual twisted pair shield control line and keep reliable earthing of shield layer;
- 4) For the motor cable exceeding 100m, output filter or electric reactor should be installed.

7.3.3 Handling method of interference produced by peripheral electromagnetic equipments for frequency converter: in general, the cause of frequency converter produces electromagnetic influence is that many relays, contactors or electromagnetic brakes are installed nearby frequency converter. If any malfunction of frequency converter due to interference, it's suggested to adopt below methods:

- 1) The devices producing interference are installed with surge suppressor;
- 2) Install filter in input terminal of frequency converter as per 7.3.6 for operation;



3) Control signal line and lead of detection circuit adopt shield cable, and keep reliable earthing.

7.3.4 Handling method of interference produced by peripheral equipments for frequency convertor: there are two kinds of noise, namely radiated interference of frequency convertor and conducted interference of frequency convertor. These two interferences lead to electromagnetic or electrostatic induction of peripheral electrical equipments, and then cause malfunction of equipments. Aiming at different interferences, below solutions can be referred:

1) The signal of instruments, receivers and sensor for measurement is generally weak. If they are near to frequency convertor or in the same control cabinet, the frequency convertor is easily interfered and malfunction produces. It's suggested to adopt below solutions: keep away from interference source as far as possible; do not layout signal line and power line in parallel, or bundle up them in parallel; signal line and power line adopt shield line, keep reliable earthing; install ferrite core (range of blanketing frequency is 30 ~ 1000MHz) on output side of frequency convertor and wind 2~3 turns in the same direction. For serious situation, EMC output filter can be installed;

2) If interfered equipments share the same power with frequency convertor, conducted interference will produce. If interference can't be eliminated through above method, EMC filter shall be installed between frequency convertor and power (refer to 7.3.6 for model selection operation);

3) Independent earthing of peripheral equipments can eliminate the interference produced by leak current of ground lead of frequency convertor.

7.3.5 Leak current and handling: there are two kinds of forms of leak current when using frequency convertor: leak current to ground, and leak current between lines.

1) Factors influencing leak current to ground and solutions:

There is distributed capacitance between wire and ground. The larger the distributed capacitance, the larger the leak current will be, so reduce the distance between frequency convertor and motor to decrease distributed capacitance. The larger the carrier frequency, the larger the leak current will be, so decrease carrier frequency to reduce leak current. However, decreasing carrier frequency will lead to increasing motor noise. Please note that installing reactor is an effective way to solve leak current.

Leak current increases with enlargement of loop current, so the larger the motor power, the larger the corresponding leak current will be.

2) Factors influencing leak current between lines and solutions:

There is distributed capacitance between output wirings of frequency convertor. If the current passing circuit contains higher harmonic, resonance may be caused to produce leak current. If using thermal relay at this time, malfunction may occur.

The solution is to reduce carrier frequency or install output reactor. When using frequency convertor, it's not suggested to install thermal relay between frequency convertor and motor, but use electric over-current protection function of frequency convertor.

7.3.6 Precautions about installing EMC input filter on power input terminal:

1) ⚠Caution: please strictly abide by rated value when using filter. As filter is I-class electric appliance, metal shell of filter should contact well with metal of installing cabinet, and good electric conduction continuity is required, otherwise there is risk of electric shock and EMC effect will be seriously influenced;

2) According to EMC test, filter and PE terminal of frequency convertor should be connected on the same ground, otherwise EMC effect will be seriously influenced;

3) The filter should be installed nearby power input terminal of frequency convertor as far as possible.

## Chapter 8 Fault diagnosis and countermeasures

### 8.1 Fault warning and countermeasures

VFD-200G frequency converter owns 24 warning information and protection functions. Once the fault occurs, protection function starts action and the frequency converter stops output. Fault relay of frequency converter starts contact action and fault code displays on display panel of frequency converter. Before users seek for service, they can examine by themselves as per instructions in this chapter to analyze fault cause and find out solutions. If the causes are those in dotted line box, please seek for service and contact with agent of frequency converter or our company directly.

Fault name	Invert unit protection
Display panel	Err01
Check fault cause	<ol style="list-style-type: none"> <li>1. Short circuit of output loop of frequency converter</li> <li>2. Too long wiring between motor and frequency converter</li> <li>3. Overheating module</li> <li>4. Internal wiring of frequency converter becomes loose</li> <li>5. Abnormal main control panel</li> <li>6. Abnormal driver board</li> <li>7. Abnormal inversion module</li> </ol>
Fault handling method	<ol style="list-style-type: none"> <li>1. Eliminate peripheral fault</li> <li>2. Install electric reactor or output filter</li> <li>3. Check if blocking of air channel and normal work of fan, eliminate existing problems</li> <li>4. Insert all connecting lines</li> <li>5. Seek for technical support</li> <li>6. Seek for technical support</li> <li>7. Seek for technical support</li> </ol>

Fault name	Accelerated over-current
Display panel	Err02
Check fault cause	<ol style="list-style-type: none"> <li>1. Earthing or short circuit of output loop of frequency converter</li> <li>2. Control way is vector and there is no parameter identification</li> <li>3. Too short acceleration time</li> <li>4. Manual torque promotion or V/F curve is not suitable</li> <li>5. Low voltage</li> <li>6. Start rotating motor</li> <li>7. Impact load during acceleration process</li> <li>8. Model selection of frequency converter is small</li> </ol>
Fault handling method	<ol style="list-style-type: none"> <li>1. Eliminate peripheral fault</li> <li>2. Conduct parameter identification of motor</li> <li>3. Increase acceleration time</li> <li>4. Adjust manual torque promotion or V/F curve</li> <li>5. Adjust voltage to normal range</li> <li>6. Start tracking rotation speed or restart after motor stops</li> <li>7. Cancel impact load</li> <li>8. Select the frequency converter with larger power grade</li> </ol>

Fault name	Accelerated over-current
Display panel	Err03
Check fault cause	<ol style="list-style-type: none"> <li>1. Earthing or short circuit of output loop of frequency convertor</li> <li>2. Control way is vector and there is no parameter identification</li> <li>3. Too short acceleration time</li> <li>4. Low voltage</li> <li>5. Impact load during acceleration process</li> <li>6. No brake unit or brake resistance is installed</li> </ol>
Fault handling method	<ol style="list-style-type: none"> <li>1. Eliminate peripheral fault</li> <li>2. Conduct parameter identification of motor</li> <li>3. Increase acceleration time</li> <li>4. Adjust voltage to normal range</li> <li>5. Cancel impact load</li> <li>6. Install brake unit and brake resistance</li> </ol>

Fault name	Constant-speed over-current
Display panel	Err04
Check fault cause	<ol style="list-style-type: none"> <li>1. Earthing or short circuit of output loop of frequency convertor</li> <li>2. Control way is vector and there is no parameter identification</li> <li>3. Low voltage</li> <li>4. Impact load during acceleration process</li> <li>5. Model selection of frequency convertor is small</li> </ol>
Fault handling method	<ol style="list-style-type: none"> <li>1. Eliminate peripheral fault</li> <li>2. Conduct parameter identification of motor</li> <li>3. Adjust voltage to normal range</li> <li>4. Cancel impact load</li> <li>5. Select the frequency convertor with larger power grade</li> </ol>

Fault name	Accelerated overvoltage
Display panel	Err05
Check fault cause	<ol style="list-style-type: none"> <li>1. Low input voltage</li> <li>2. External force drives motor to operate during acceleration process</li> <li>3. Too short acceleration time</li> <li>4. No brake unit or brake resistance is installed</li> </ol>
Fault handling method	<ol style="list-style-type: none"> <li>1. Adjust voltage to normal range</li> <li>2. Cancel external force or install brake resistance</li> <li>3. Increase acceleration time</li> <li>4. Install brake unit and brake resistance</li> </ol>

Fault name	Decelerated overvoltage
Display panel	Err06
Check fault cause	<ol style="list-style-type: none"> <li>1. High input voltage</li> <li>2. External force drives motor to operate during deceleration process</li> <li>3. Too short deceleration time</li> <li>4. No brake unit or brake resistance is installed</li> </ol>
Fault handling method	<ol style="list-style-type: none"> <li>1. Adjust voltage to normal range</li> <li>2. Cancel external force or install brake resistance</li> <li>3. Increase deceleration time</li> <li>4. Install brake unit and brake resistance</li> </ol>

Fault name	Constant-speed overvoltage
Display panel	Err07
Check fault cause	1. High input voltage 2. External force drives motor to operate during deceleration process
Fault handling method	1. Adjust voltage to normal range 2. Cancel external force or install brake resistance

Fault name	Fault of control power
Display panel	Err08
Check fault cause	1. Input voltage is not within specified range
Fault handling method	1. Adjust voltage to specified range

Fault name	Undervoltage fault
Display panel	Err09
Check fault cause	1. Instantaneous power failure 2. Voltage on input terminal of frequency convertor is not within specified range 3. Abnormal busbar voltage 4. Abnormal rectifier bridge and buffer resistance 5. Abnormal driver board 6. Abnormal control panel
Fault handling method	1. Reset fault 2. Adjust voltage to normal range 3. Seek for technical support 4. Seek for technical support 5. Seek for technical support 6. Seek for technical support

Fault name	Overload of frequency convertor
Display panel	Err10
Check fault cause	1. Too large load or locked-rotor of motor 2. Model selection of frequency convertor is small
Fault handling method	1. Decrease load, check motor and machinery 2. Select the frequency convertor with larger power grade

Fault name	Overload of motor
Display panel	Err11
Check fault cause	1. Is protection parameter P9-01 of motor set properly 2. Too large load or locked-rotor of motor 3. Model selection of frequency convertor is small
Fault handling method	1. Set the parameter correctly 2. Decrease load, check motor and machinery 3. Select the frequency convertor with larger power grade

Fault name	Input default phase
Display panel	Err12
Check fault cause	<ol style="list-style-type: none"> <li>1. Abnormal three-phase input power</li> <li>2. Abnormal driver board</li> <li>3. Abnormal anti-thunder panel</li> <li>4. Abnormal main control panel</li> </ol>
Fault handling method	<ol style="list-style-type: none"> <li>1. Check and eliminate problems in peripheral circuit</li> <li>2. Seek for technical support</li> <li>3. Seek for technical support</li> <li>4. Seek for technical support</li> </ol>

Fault name	Output default phase
Display panel	Err13
Check fault cause	<ol style="list-style-type: none"> <li>1. Abnormal lead from frequency convertor to motor</li> <li>2. Unbalanced three-phase output of frequency convertor during motor operation</li> <li>3. Abnormal driver board</li> <li>4. Abnormal module</li> </ol>
Fault handling method	<ol style="list-style-type: none"> <li>1. Eliminate peripheral fault</li> <li>2. Check if three-phase winding is normal and remove fault</li> <li>3. Seek for technical support</li> <li>4. Seek for technical support</li> </ol>

Fault name	Overheating module
Display panel	Err14
Check fault cause	<ol style="list-style-type: none"> <li>1. Too high environment temperature</li> <li>2. Air channel is blocked</li> <li>3. Fan is damaged</li> <li>4. Thermistor of module is damaged</li> <li>5. Inverter module is damaged</li> </ol>
Fault handling method	<ol style="list-style-type: none"> <li>1. Reduce environment temperature</li> <li>2. Clear the fan</li> <li>3. Change the fan</li> <li>4. Change the thermistor</li> <li>5. Change the inverter module</li> </ol>

Fault name	Fault of peripheral equipment
Display panel	Err15
Check fault cause	<ol style="list-style-type: none"> <li>1. Input signal of external fault through multi-function terminal DI</li> <li>2. Input signal of external fault through virtual IO function</li> </ol>
Fault handling method	<ol style="list-style-type: none"> <li>1. Reset operation</li> <li>2. Reset operation</li> </ol>

Fault name	Communication fault
Display panel	Err16
Check fault cause	<ol style="list-style-type: none"> <li>1. Abnormal work of host computer</li> <li>2. Abnormal communication line</li> <li>3. Incorrect setting of communication expansion card P0-28</li> <li>4. Incorrect setting of PD group of communication parameter</li> </ol>

Specification of VFD-200G high-performance vector convertor      Fault diagnosis and

Fault handling method	<ol style="list-style-type: none"> <li>1. Check wiring of host computer</li> <li>2. Check wiring of communication line</li> <li>3. Set type of communication expansion card correctly</li> <li>4. Set communication parameters correctly</li> </ol>
-----------------------	---

Fault name	Contactor fault
Display panel	Err17
Check fault cause	<ol style="list-style-type: none"> <li>1. Abnormal driver board and power</li> <li>2. Abnormal contactor</li> </ol>
Fault handling method	<ol style="list-style-type: none"> <li>1. Change driver board or power</li> <li>2. Change contactor</li> </ol>

Fault name	Fault of current detection
Display panel	Err18
Check fault cause	<ol style="list-style-type: none"> <li>1. Abnormal Hall device</li> <li>2. Abnormal driver board</li> </ol>
Fault handling method	<ol style="list-style-type: none"> <li>1. Change Hall device</li> <li>2. Change driver board</li> </ol>

Fault name	Tuning fault of motor
Display panel	Err19
Check fault cause	<ol style="list-style-type: none"> <li>1. Motor parameter is not set as per nameplate</li> <li>2. Parameter identification process overtimes</li> </ol>
Fault handling method	<ol style="list-style-type: none"> <li>1. Set motor parameter correctly as per nameplate</li> <li>2. Check the lead between frequency convertor and motor</li> </ol>

Fault name	Fault of encoding disk
Display panel	Err20
Check fault cause	<ol style="list-style-type: none"> <li>1. Model of encoder does not match</li> <li>2. Incorrect wiring of encoder</li> <li>3. Encoder is damaged</li> <li>4. Abnormal PG card</li> </ol>
Fault handling method	<ol style="list-style-type: none"> <li>1. Set model of encoder correctly based on actual situation</li> <li>2. Remove wiring fault</li> <li>3. Change encoder</li> <li>4. Change PG card</li> </ol>

Fault name	Read-write fault of EEPROM
Display panel	Err21
Check fault cause	1. EEPROM chip is damaged
Fault handling method	1. Change main control panel

Fault diagnosis and countermeasures                      Specification of VFD-200G high-performance vector

Fault name	Hardware fault of frequency convertor
Display panel	Err22
Check fault cause	1. Overvoltage exists 2. Over-current exists
Fault handling method	1. Process as per overvoltage fault 2. Process as per over-current fault

Fault name	To-ground short circuit fault
Display panel	Err23
Check fault cause	1. To-ground short circuit of motor
Fault handling method	1. Change cable or motor

Fault name	Fault of reaching accumulative operation time
Display panel	Err26
Check fault cause	1. Accumulative operation time reaches set value
Fault handling method	1. Use parameter initialization function to eliminate recorded information

Fault name	User defined fault 1
Display panel	Err27
Check fault cause	1. Input signal of user defined fault 1 through multi-function terminal DI 2. Input signal of user defined fault 1 through virtual IO function
Fault handling method	1. Reset operation 2. Reset operation

Fault name	User defined fault 2
Display panel	Err28
Check fault cause	1. Input signal of user defined fault 2 through multi-function terminal DI 2. Input signal of user defined fault 2 through virtual IO function
Fault handling method	1. Reset operation 2. Reset operation

Fault name	Fault of reaching accumulative electrifying time
Display panel	Err29
Check fault cause	1. Accumulative electrifying time reaches set value
Fault handling method	1. Use parameter initialization function to eliminate recorded information

Fault name	Off-load fault
Display panel	Err30
Check fault cause	1. Running current of frequency convertor is < P9-64
Fault handling method	1. Confirm if load is separated or if P9-64, P9-65 parameter settings conform to actual operation condition

Specification of VFD-200G high-performance vector converter      Fault diagnosis and

Fault name	Fault of PID feedback loss during operation
Display panel	Err31
Check fault cause	1. PID feedback is smaller than PA-26 set value
Fault handling method	1. Check PID feedback signal or set PA-26 to be a suitable value

Fault name	Cycle-by-cycle over-current fault
Display panel	Err40
Check fault cause	1. Too large load or locked-rotor of motor 2. Model selection of frequency convertor is small
Fault handling method	1. Decrease load, check motor and machinery 2. Select the frequency convertor with larger power grade

Fault name	Fault of motor switch during operation
Display panel	Err41
Check fault cause	1. Alter current motor selection through terminal during operation of frequency convertor
Fault handling method	1. Switch motor after frequency convertor halts

Fault name	Fault of too large speed deviation
Display panel	Err42
Check fault cause	1. Incorrect parameter setting of encoder 2. No parameter identification is conducted 3. Too large speed deviation, parameter settings of P9-69, P9-60 are irrational
Fault handling method	1. Set parameters of encoder correctly 2. Conduct parameter identification 3. Set detection parameters rationally based on actual situation

Fault name	Over-speed fault of motor
Display panel	Err43
Check fault cause	1. Incorrect parameter setting of encoder 2. No parameter identification is conducted 3. Settings of over-speed detection parameters P9-69, P9-60 are irrational
Fault handling method	1. Set parameters of encoder correctly 2. Conduct parameter identification 3. Set detection parameters rationally based on actual situation

Fault name	Over-temperature fault of motor
Display panel	Err45
Check fault cause	1. Wiring of temperature sensor is loose 2. Motor temperature is too high
Fault handling method	1. Detect temperature sensor and eliminate fault 2. Decrease carrier frequency or adopt other heat dissipation measures to handle heat dissipation of motor



Fault name	Incorrect initial position
Display panel	Err51
Check fault cause	1. Motor parameter deviates largely from actual value
Fault handling method	1. Reconfirm if motor parameters are correct especially if setting of rated current is small

### 8.2 Common faults and handling methods

Below fault s may occur during using process of frequency convertor, please refer to below methods for simple fault analysis:

Figure 8-1 Common faults and handling methods

No.	Fault phenomenon	Possible causes	Solutions
1	No display when electrifying	No or too low network voltage; fault of switch power on driver board of frequency convertor; rectifier bridge is damaged; buffer resistance of frequency convertor is damaged; fault of control panel and keyboard; disconnected wiring between control panel, driver board and keyboard;	Check input power; check busbar voltage; pull out and insert flat cable again; seek for service from manufacturer
2	Display HC when electrifying	Bad contact between driver board and control panel; Related devices on control panel are damaged; to-ground short-circuit of motor or motor line; Hall fault; too low network voltage;	Pull out and insert flat cable again; seek for service from manufacturer
3	Display “Err23” when electrifying	To-ground short-circuit of motor or output line; frequency convertor is damaged;	Measure insulation between motor and output line with tramegger; seek for service from manufacturer
4	Normal display when electrifying, display “HC” after operation and shut down	Fan is damaged or blocked; short-circuit wiring of peripheral control terminal;	Change fan; eliminate external short-circuit fault
5	Frequent alarm of Err14 (overheating module)	Higer setting of carrier frequency; fan is damaged or air channel is blocked; internal devices of frequency convertor are damaged (thermocouple or others)	Reduce carrier frequency (P0-15); change fan, clear air channel; seek for service from manufacturer
6	Motor doesn’t rotate after frequency convertor operates	Motor and motor line; wrong parameter setting of frequency convertor (motor parameter); bad contact between driver board and control panel; fault of driver board	Reconfirm wiring between frequency convertor and motor; change motor or eliminate mechanical fault; check and reset motor parameters
7	Invalid DI terminal	Wrong parameter settings; external signal error; OP and +24V jumper loose; fault of control panel	Check and reset parameters of P4 group; reconnect external signal line; reconfirm OP and +24V jumpers; seek for service from manufacturer
8	Motor speed can’t promote when closed-loop vector controls	Encoder fault; wrong wiring or poor contact of encoder; fault of PG card; fault of driver board	Change code disk and reconfirm wiring; change PG card; seek for service
9	Frequent alarm of overvoltage and over-current fault	Incorrect parameter setting of motor; inappropriate acceleration/deceleration time; fluctuation of load;	Reset motor parameters or tune motor; set acceleration and deceleration time; seek for service from manufacturer

No.	Fault phenomenon	Possible causes	Solutions
10	Display Err17 when electrifying (or operating)	Soft starting contactor is not closed;	Check if contactor cable is loose; check if any fault with contactor; check if any fault with 24V power supply of contactor; seek for service from manufacturer;
11	Display <u>EEEE</u> when electrifying	Related devices on control panel are damaged;	Change control panel;

## Appendix A: Multi-function card VFD-200GPC1

(Apply to machines at 3.7kW and above)

### I. Introduction

VFD-200GPC1 card is a multi-function expansion card released by Company to match with VFD-200G series frequency convertor. It contains below resources:

Item	Specification	Description
Input terminal	5-pin digital signal input	
	1-pin analog voltage signal input	Support voltage input signal at $-10V \sim 10V$
Output terminal	1-pin relay signal output	
	1-pin digital signal output	
	1-pin analog signal output	
Communication	RS-485 communication interface	Support Modbus-RTU communication protocol (see details in Appendix I: VFD-200G Modbus communication protocol)
	CAN communication interface	Support CANlink communication protocol

### II. Mechanical installation and functional descriptions of control terminals

1. Installation way, functional definitions of control terminals and jumper descriptions can respectively refer to Figure 1, Table 1 and Table 2 in Appendix 1

- 1) Please install after complete outage of frequency converter;
- 2) Align expansion card interface and location hole of multi-function card and control panel on frequency convertor;
- 3) Fix with screw.

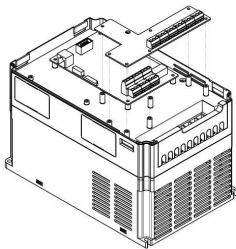

Appendix A: Figure1 Installation way of multi-function card

## Appendix A: Functional descriptions of control terminals

Category	Terminal symbol	Terminal name	Functional description
Power	+24V-COM	Connect +24V power externally	Provide +24V power externally, be used as working power of digital input and output terminal as well as power of external sensor; maximum current current: 200mA
	OP1	Power terminal of digital input	OP1 and "+24V" have been connected by J8 when leaving factory. If using external power, OP1 shall connect with external power and pull out J8
Analog input	AI3-PGND	Analog input terminal 3	1. Opto-isolator input, differential voltage input and temperature sense resistor input are accepted 2. Input voltage range: DC -10V~10V 3. PT100, PT1000 temperature sensor 4. Use dial switch S1 to decide input way, do not use different functions at the same time
Function digital input terminals	DI6-OP1	Digital input 6	1. Opto-isolator: be compatible with bipolar input 2. Input impedance: 2.4kΩ 3. Voltage range during level input: 9~30V
	DI7-OP1	Digital input 7	
	DI8-OP1	Digital input 8	
	DI9-OP1	Digital input 9	
	DI10-OP1	Digital input 10	
Analog output	AO2-GND	Analog output 2	1. Specification of output voltage: 0 V~10V 2. Specification of output current: 0mV~20mV
Digital output	DO2-CME	Digital output 2	Opto-isolator, output voltage range of bipolar open collector: 0V~24V, output current range: 0mA~50mA. Attention: digital output CME1 and digital input COM are internally isolated, and J7 connection is by default. If DO2 needs to drive by external power, J7 must be disconnected
Relay output (RELAY2)	PA- PB	Normally-closed terminal	Drive capability of contact: AC250V, 3A, COSφ=0.4. DC 30V, 1A
	PA- PC	Normally-open terminal	
RS-485 communication	485+/485-	Communication interface terminal	Input and output signal terminals of Modbus-RTU protocol communication, isolation input
CAN communication	CANH/CANL	Communication interface terminal	Input terminal of CANlink protocol communication, isolation input

Appendix A: Table 2 Jumper description

Jumper No.	Description
J3	AO2 output selection-voltage, current
J4	Select matched resistance for CAN terminal
J1	Select matched resistance for RS485 terminal
J7	Select CME1 connection way
J8	Select OP1 connection way
S1	Function selection of AI3, PT100, PT1000

## Appendix B: Instructions of IO expansion card (VFD-200GIO1)

(Apply to all series machines)

### I. Introduction

IO expansion card VFD-200GIO1 offers 3-pin DI.

### II. Mechanical installation and functional descriptions of control terminals

1. Installation way and functional definitions of wiring terminals can respectively refer to Figure 1 and Table 1 in Appendix 2

- 1) Please assemble and disassemble after complete outage of frequency convertor;
- 2) Align expansion card interface and location hole of I/O expansion card and control panel on frequency convertor;
- 3) Fix communication card with screw as shown in Figure 1.

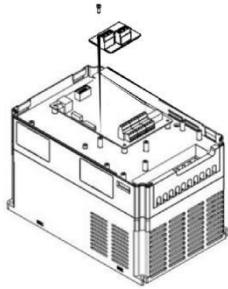

Appendix B: Figure 1 Installation way of VFD-200GIO1

Function definition of wiring terminals:

Appendix B: Table 1 Functional descriptions of wiring terminals

Category	Terminal symbol	Terminal name	Functional description
Power	+24V-COM	Connect +24V power externally	Provide +24V power externally, be used as working power of digital input/output terminal as well as power of external sensor; maximum current current: 200mA
	OP2	Power terminal of digital input	No power connection of OP2 when leaving factory, connect to external power based on demands
Function digital input terminals	DI6-OP2	Digital input 6	1. Opto-isolator: be compatible with bipolar input 2. Input impedance: DI6, DI7: 3.3kΩ, DI8: 2.4kΩ 3. Voltage range during level input: 9~30V 4. DI6, DI7 are common input terminals, input frequency <100Hz; DI8 is high-speed pulse input terminal, max. input frequency <100kHz
	DI7-OP2	Digital input 7	
	DI8-OP2	Digital input 8	

## Appendix C: Instructions of expansion card for common encoder

(Apply to all series machines)

### I. Introduction

VFD-200G is equipped with expansion card for common encoder (namely PG card). As an optional accessory, it's necessary for closed-loop vector control of frequency converter. Select corresponding PG card as per output way of encoder, and the specific models are as follows:

Optional accessories	Description	Other
VFD-200GPG1	Differential input of PG card without frequency dividing output	Terminal wiring
VFD-200GPG2	PG card of rotary transformer	DB9 bus socket
VFD-200GPG3	OC input of PG card, frequency dividing output at 1:1	Terminal wiring

### II. Mechanical installation and functional descriptions of control terminals

1. Installation way, appearance, specification and signal definition of wiring terminal can respectively refer to Figure 1 and Table 1 in Appendix C:

- 1) Please assemble and disassemble PG card after complete outage of frequency converter;
- 2) Connect J3 on control panel with expansion card through 18pin FFC (ensure correct installation and proper snap joint).

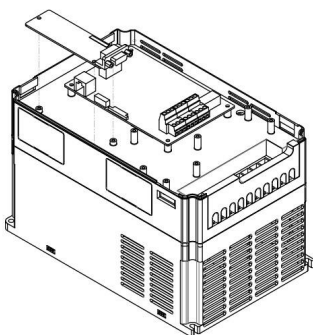

Appendix E: Figure 1 Installation way of expansion card for encoder

Specifications of expansion card for encoder and signal definitions of wiring terminals are as below:

Appendix C: Table 1 Specification and signal definitions of wiring terminals

Differential PG card (VFD-200GPG1)		
VFD-200GPG1 specification		
User interface	Oblique cutting terminal	
Distance	3.5mm	
Screw	Straight	
Pluggable	No	
Wire gauge	16-26AWG	
Maximum rate	500kHz	
Differential signal amplitude of input	≤7V	
VFD-200GPG1 signal definition of wiring		
No.	Symbol	Description
1	A+	Encoder output A signal +
2	A-	Encoder output A signal -
3	B+	Encoder output B signal +
4	B-	Encoder output B signal -
5	Z+	Encoder output Z signal +
6	Z-	Encoder output Z signal -
7	5V	Provide 5V/100mA power externally
8	COM	Power ground
9	PE	Shield terminal
PG card of rotary transformer (VFD-200GPG2)		
VFD-200GPG2 specification		
User interface	DB9 female contact	
Pluggable	Yes	
Wire gauge	>22AWG	
Resolution ratio	12 digit	
Driving frequency	10kHz	
VRMS	7V	
VP-P	3.15±27%	
VFD-200GPG2 terminal		
No.	Symbol	Description
1	EXC1	- driving of rotary transformer
2	EXC	+ driving of rotary transformer
3	SIN	+ feedback SIN of rotary transformer
4	SINLO	- feedback SIN of rotary transformer
5	COS	+ feedback COS of rotary transformer
6-8	-	-
9	COSLO	- feedback COS of rotary transformer

OC PG card (VFD-200GPG3)		
VFD-200GPG3 specification		
User interface	Oblique cutting terminal	
Distance	3.5mm	
Screw	Straight	
Pluggable	No	
Wire gauge	16-26AWG	
Maximum rate	100KHz	
VFD-200GPG3 terminal		
No.	Symbol	Description
1	A	Encoder output A signal
2	B	Encoder output B signal
3	Z	Encoder output Z signal
4	15V	Provide 15V/100mA power externally
5	COM	Power ground
6	COM	Power ground
7	A1	PG card feedback output A signal at 1:1
8	B1	PG card feedback output B signal at 1:1
9	PE	Shield terminal

## Appendix D: Instructions of CANlink communication expansion card (VFD-200GCAN1)

(Apply to all series)

### I. Introduction

It's specially developed for CANlink communication function of VFD-200G series frequency convertor.

### II. Mechanical installation and functional descriptions of control terminals

1. Installation way and appendix B: the same with IO expansion card (VFD-200GIO1). Functional descriptions of wiring terminals and jumper descriptions respectively refer to Figure 1, Table 1 and Table 2 in Appendix D:

Appendix D: Table 1 Functional description of control terminal

Category	Terminal symbol	Terminal name	Functional description
CAN communication (CN1)	CANH/CANL	Communication interface terminal	CAN communication input terminal
	COM	Power ground of CAN communication	

Appendix D: Table 2 Jumper description

Jumper No.	Description



J2	Select matched resistance for CAN terminal
----	--

## Appendix E: Instructions of RS-485 communication expansion card (VFD-200GTX1)

(Apply to all series)

### I. Introduction

It's specially developed for 485 communication function of VFD-200G series frequency convertor. By adopting isolation scheme, electric parameters conform to international standard and users can select based on demands so as to control operation of frequency convertor and set parameters through remote serial port;

### II. Mechanical installation and functional descriptions of control terminals

1. Installation way and appendix B: the same with IO expansion card (VFD-200GIO1). Functional descriptions of wiring terminals and dial-up definitions respectively refer to Table 1 and Table 2 in Appendix E:

Functional description of control terminal:

Appendix E: Table 1 Functional  
description of control terminal

Category	Terminal symbol	Terminal name	Functional description
485 communication (CN1)	485+/485-	Communication interface terminal	485 communication input terminal, isolation input
	CGND	Power ground of 485 communication	Isolated power

Jumper description:

Appendix E: Table 2  
Jumper description

Jumper No.	Description
J1	Select matched resistance for 485 terminal

Note:

To prevent communication signal from external interference, communication wire can use twisted pair and avoid using parallel lines as far as possible;

## Appendix F: VFD-200G Modbus communication protocol

VFD-200G series frequency convertor provides RS232/RS485 communication interface and supports Modbus communication protocol. Users can realize centralized control through computer or PLC, set run command of frequency convertor through communication protocol, modify or read parameters of function code, read working condition and fault information of frequency convertor, etc.

### I. Protocol content

The serial communication protocol defines transmissive information contents and using format of serial communication, including format for polling of host (or broadcast), encoding method of host such as function code of required action, transmission data and error verification, etc. The response of slave also adopts same structure and the contents include action confirmation, data return and error verification, etc. If any error of slave when receiving information or failure to finish the action required by host, the slave will organize a fault message as response feedback for the host.

Application mode: frequency convertor accesses to “single-host and multiple-slave” PC/PLC control network with RS232/RS485 bus.

#### Structure of bus

##### (1) Interface mode

RS232/RS485 hardware interface

(2) Transmission mode: asynchronous serial and half-duplex. For the host and slave at the same moment, one can only send data and another can only receive data. During serial asynchronous communication process, data is sent with the form of message frame by frame.

(3) Topological structure: single-host and multiple-slave system. The setting range of slave address is 1~247 and 0 is address of broadcast communication. Slave address in network should be unique.

#### Protocol description

Communication protocol of VFD-200G series frequency convertor is a kind of asynchronous serial master-slave Modbus communication protocol, and only one device (host) in the network can establish protocol (called as “query/command”). Other devices (slave) can only response the “query/command” of host by providing data or take corresponding actions based on “query/command” of host. Host refers to personal computer (PC), industrial control equipment or programmable logic controller (PLC), etc, and slave means VFD-200G series frequency convertor. The host can not only communicate with certain slave separately, but issue broadcast information to all inferior slaves. For separately accessed “query/command” of host, the slave needs to return a message (called as response). For the broadcast information issued by the host, the slave does not need to feedback response to host.

Structure of communication materials: communication data format of modbus protocol for VFD-200G series frequency convertor is as below:

For RTU mode, message sending starts with pause time for at least 3.5 characters. Diverse character time under network Baud rate is easily realized (as shown in below T1-T2-T3-T4). The first domain of transmission is equipment address.

The available transmission character is hexadecimal 0..9, A..F. Network equipment detects network bus constantly, including pausing interval time. When receiving first domain (address domain), each equipment will decode to judge if sending to own. After the last transmission character, the pause time of at least 3.5 characters marks the ending of message. A new message will start after the pause.

The whole message frame should be continuous streaming transfer. If the dwell time exceeds 1.5 characters before frame finishes, receiving equipment will refresh incomplete message and assume that next byte is address domain of a new message. Similarly, if a new message starts within time of 3.5 characters following previous message, receiving equipment will consider it as the delay of previous message, and then error will be caused, as it's impossible for the value of final CRC domain to be correct.

RTU frame format

Frame header START	Time of 3.5 characters
Slave ADR	Address: 1~247
CMD code	03: read slave parameters; 06: write slave parameters
DATA (N-1)	Data content: address of function code parameters, number of function code parameters, value of function code parameters, etc
DATA (N-2)	
.....	
DATA0	
CRC CHK high-order	Detection value: CRC value
CRC CHK low-order	
END	Time of 3.5 characters

**CMD and DATA**

CMD code: 03H, read N word (12 words at most). For example: start address F002 of frequency converter with slave address being 01 reads 2 values successively

CMD message of host

ADR	01H
CMD	03H
Start address high-order	F0H
Start address low-order	02H
Register No. high-order	00H
Register No. low-order	02H
CRC CHK high-order	CRC CHK value to be calculated
CRC CHK low-order	

Response message of slave

**PD-05** is set as **0**:

ADR	01H
CMD	03H
Byte No. high-order	00H
Byte No. low-order	04H
Data F002H high-order	00H
Data F002H low-order	00H
Data F003H high-order	00H
Data F003H low-order	01H
CRC CHK low-order	CRC CHK value to be calculated
CRC CHK high-order	

**FD-05** is set as **1**:

ADR	01H
CMD	03H
Byte No.	04H
Data F002H high-order	00H
Data F002H low-order	00H
Data F003H high-order	00H
Data F003H low-order	01H
CRC CHK low-order	CRC CHK value to be calculated
CRC CHK high-order	

CMD code: 06H, write one word. For example: write 5000 (1388H) in F00AH address of frequency convertor with slave address being 02H.

CMD message of host

ADR	02H
CMD	06H
Data address high-order	F0H
Data address low-order	0AH
Data content high-order	13H
Data content low-order	88H
CRC CHK low-order	CRC CHK value to be calculated
CRC CHK high-order	

Response message of slave

ADR	02H
CMD	06H
Data address high-order	F0H
Data address low-order	0AH
Data content high-order	13H
Data content low-order	88H
CRC CHK low-order	CRC CHK value to be calculated
CRC CHK high-order	

Verification mode-CRC verification mode: CRC (Cyclical Redundancy Check) uses RTU frame format, and message includes error detection domain based on CRC method. CRC domain detects the contents of whole message. CRC domain is two-byte and includes 16-bit binary system value. It's added to message after calculation by transmission equipment. Receiving equipment recalculates CRC of received message and compares with value in received CRC domain. If two CRC values are not equal, the transmission is wrong.

CRC firstly stores 0xFFFF, and then calls a course to process successive 8-bit bytes in message and value in current register. Only 8Bit data in each character is valid for CRC, start bit, stop bit and parity check bit are invalid.

During producing process of CRC, each 8-bit byte is XOR with register contents separately. Finally, it moves to the direction of least significant bit, and most significant bit is filled with 0. LSB is extracted for detection. If LSB is 1, register is XOR with preset value. If LSB is 0, no action. Repeat the whole process for 8 times. After last bit (8<sup>th</sup> bit) finishes, next 8-bit byte is XOR with current value of register alone. The final value in register is CRC value after all bytes in message are executed.

When adding CRC to message, add low byte firstly and then high byte. Simple function of CRC is as below:

```

unsigned int crc_chk_value ( unsigned char *data_value, unsigned char length ) {
    unsigned int crc_value=0xFFFF;
    int i;
    while ( length-- )
        {
            crc_value^=*data_value++;
            for ( i=0;i<8;i++ )
                {
                    if ( crc_value&0x0001 )
                        crc_value= ( crc_value>>1 )
^0xa001;
                    }
                else
                {
                    crc_value=crc_value>>1;
                }
            }
        }
    return ( crc_value ) ;
}

```

Address definition of communication parameter

This part is communication content used for controlling operation of frequency convertor, setting state and related parameters of frequency convertor.

Read-write function code parameter (some function codes can't be modified, but are simply used or monitored by manufacturer).

Marking rules of function code parameter address:

Express rules with group No. and marking No. of function code being parameter address:

High byte: P0~PF (P group), A0~AF (A group), 70~7F (U group); low byte: 00~FF

E.g.: P3-12, address is expressed as P30C;

Note: PF group: neither read nor modify parameters;

U group: only read but not modify parameters.

When the frequency convertor is in running status, some parameters can't be modified. Some parameters can't be modified no matter what is the status of frequency convertor. When modifying the function code parameters, range, unit and related descriptions of parameters should be also noticed.

Besides, as EEPROM is frequently stored, it will reduce lifespan of EEPROM. Therefore, under communication mode, some function codes don't have to be stored, and only modify the value in RAM.

If it's P group parameter, changing high-order F of the function code address to be 0 can realize the function. If it's A group parameter, changing high-order A of the function code address to be 4 can realize the function. Corresponding function code address is expressed as below: high-order byte: 00~0F (P group), 40~4F (A group); low-order byte: 00~FF

E.g.: function code P3-12 is not stored in EEPROM, the address is expressed as 030C; function code A0-05 is not stored in EEPROM, the address is expressed as 4005; the address can only write RAM and conduct read action. When reading, it's invalid address. For all parameters, CMD code 07H can also be used to realize the function.

When the frequency convertor is in running status, some parameters can't be modified. Some parameters can't be modified no matter what is the status of frequency convertor. When modifying the function code parameters, range, unit and related descriptions of parameters should be also noticed.

Halt/running parameters:

Parameter address	Parameter description
1000	*Communication setting value (-10000~10000) (decimal system)
1001	Running frequency
1002	Busbar voltage
1003	Output voltage
1004	Output current
1005	Output power
1006	Output torque
1007	Running speed
1008	DI input mark
1009	DO output mark
100A	AI1 voltage
100B	AI2 voltage
100C	AI3 voltage
100D	Count value input
100E	Length value input
100F	Loading speed
1010	PID setting
1011	PID feedback
1012	PLC step
1013	PULSE frequency, unit 0.01kHz
1014	Feedback speed, unit 0.1Hz
1015	Surplus running time
1016	AI1 voltage before calibration
1017	AI2 voltage before calibration

Parameter address	Parameter description
1018	AI3 voltage before calibration
1019	Linear speed
101A	Current electrifying time
101B	Current running time
101C	PULSE frequency, unit 1Hz
101D	Communication setting value
101E	Actual feedback speed
101F	Principal frequency X display
1020	Auxiliary frequency Y display

Note:

Communication setting value is percentage of relative value, namely 10000 corresponds to 100.00%, -10000 corresponds to -100.00%. For frequency dimension, this percent is the percentage of relatively largest frequency (P0-10). For the data of torque dimension, this percent is P2-10, A2-48, A3-48, A4-48 (upper limit setting of torque respectively corresponds to first and second motor).

Input command order to frequency converter: (only write)

Command word address	Command function
2000	0001: forward operation
	0002: reverse operation
	0003: forward inching
	0004: reverse inching
	0005: free halt
	0006: deceleration halt
	0007: fault reset

Read status of frequency converter: (only read)

Status word address	Status word function
3000	0001: forward operation
	0002: reverse operation
	0003: halt

Cryptographic check of parameter locking: (if returning to be 8888H, pass cryptographic check)

Password address	Contents of inputting password
1F00	*****



Command address	Command contents
2001	BIT0: DO1 output control BIT1: DO2 output control BIT2: RELAY1 output control BIT3: RELAY2 output control BIT4: FMR output control BIT5: VDO1 BIT6: VDO2 BIT7: VDO3 BIT8: VDO4 BIT9: VDO5

Control of analog output **AO1**: (only write)

Command address	Command contents
2002	0~7FFF means 0%~100%

Control of analog output **AO2**: (only write)

Command address	Command contents
2003	0~7FFF means 0%~100%

Control of **PULSE** output: (only write)

Command address	Command contents
2004	0~7FFF means 0%~100%

Fault description of frequency converter:

Fault address	Fault message
8000	0000: no fault 0001: reserve 0002: accelerated overcurrent 0003: decelerated overcurrent 0004: constant-speed overcurrent 0005: accelerated overvoltage 0006: decelerated overvoltage 0007: constant-speed overvoltage 0008: overload fault of buffer resistance 0009: undervoltage fault 000A: overload of frequency converter 000B: overload of motor 000CL: default phase of input 000D: default phase of output 000E: overheating module 000F: external fault 0010: abnormal communication 0011: abnormal contactor 0012: current detection fault 0013: motor tuning fault 0014: fault of encoder/PG card 0015: abnormal read-write of parameter 0016: hardware fault of frequency converter 0017: to-ground short-circuit fault of motor 0018: reserve 0019: reserve 001A: reach running time 001B: user-defined fault 1 001C: user-defined fault 2 001D: reach electrifying time 001E: off-load 001F: PID feedback loss during operation 0028: overtime fault of fast current-limiting 0029: fault of motor switch during operation 002A: too large velocity misalignment 002B: supervelocity of motor 002D: over-temperature of motor 005A: wrong setting of line number of encoder 005B: not connecting with encoder 005C: error of initial position 005E: error of velocity feedback

Communication fault address	Functional description of fault
8001	0000: no fault 0001: wrong password 0002: wrong command code 0003: wrong CRC verification 0004: invalid address 0005: invalid parameter 0006: invalid parameter alternation 0007: system is locked 0008: EEPROM operation is proceeding

Description of **PD** group communication parameters

	Baud rate	Factory default	6005
Pd-00	Setting range	Unit: MODUBS Baud rate 0: 300BPS 1: 600BPS 2: 1200BPS 3: 2400BPS 4: 4800BPS 5: 9600BPS 6: 19200BPS 7: 38400BPS 8: 57600BPS 9: 115200BPS	

The parameter is used to set data transmission rate between host computer and frequency convertor. Please note that the Baud rate of host computer and frequency convertor should be consistent. Otherwise, communication is unable to proceed. The larger the Baud rate, the faster the communication speed.

	Data format	Factory default	0
Fd-01	Setting range	0: no verification: data format <8,N,2> 1: even verification: data format <8,E,1> 2: odd verification: data format <8,O,1> 3: no verification: data format <8-N-1>	

The data format of host computer and frequency convertor should be consistent. Otherwise, communication is unable to proceed.

	Local address	Factory default	1
Pd-02	Setting range	1~247, 0 is broadcast address	

If local address is set as 0, namely broadcast address, broadcast function of host computer can be realized.

Local address is unique (apart from broadcast address), and it's the basis to realize point-to-point communication between host computer and frequency convertor.

	Response delay	Factory default	2ms
Pd-03	Setting range	0~20ms	

Response delay: interval time between ending time of data reception of frequency convertor and time of sending data of host computer. If response delay is shorter than system processing time, response delay takes system processing time as criterion. If response delay is longer than system

processing time, delay await is required after system processes data. After reaching response delay time, data will be sent to host computer.

Pd-04	Communication overtime	Factory default	0.0 s
	Setting range	0.0 s (invalid) 0.1~60.0s	

If function code is set to be 0.0s, parameter of communication overtime is invalid.

If function code is set to be valid value, interval time between one communication and next communication exceeds communication overtime, the system will give alarm of communication fault (Err 16). Under normal conditions, it's set to be invalid. If setting sub-parameter in the system of continuous communication, communication status can be monitored.

Pd-05	Communication protocol	Factory default	0
	Setting range	0: non-standard Modbus protocol 1: Standard Modbus protocol	

PD-05=1: select standard Modbus protocol.

PD-05=0: when reading command, number of bytes returned by slave has one more byte than standard Modbus protocol. See details in "5 communication data structure" of the protocol.

Pd-05	Communication reads current resolution	Factory default	0
	Setting range	0: 0.01A 1: 0.1A	

It's used to confirm output unit of current value when communication reads output current.

---

Please give this user's manual to  
the end user and keep it properly.

---